

test with confidence

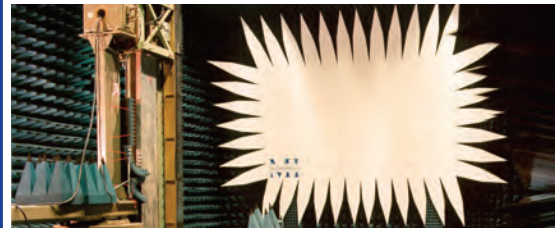
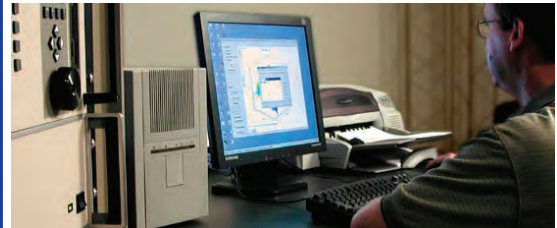

MTI
Technologies
TVU™

MI TECHNOLOGIES

Delivering engineering solutions and advanced products for a wide range of technical applications where precise measurement, control or data acquisition is required. We apply our expertise in microwave technology, electromagnetic propagation and mechanical design to provide:

Complete Solutions



Aerospace

Radar cross section
Radome measurements
In-system antenna test
Active array performance



Satellite

Link performance
Integrated system test
Ground station products
Precision payload positioning



Automotive

Full scale measurement
In-system antenna test
Test satellite, data, radio,
GPS, and safety systems



Wireless

Base station antenna test
Handset performance
Active antenna test
Free space characterization



Research

University laboratories
Government development programs
Industry R&D facilities
Standards and compliance labs

Using Standard Systems

Outdoor far field
Indoor far field
Compact range
Planar near field
Spherical near field
Cylindrical near field

From Performance Products

Microwave instruments
Mechanical positioning
Compact range reflectors
Radar cross section pylons
Rotators
Data acquisition and analysis software
Antennas and components

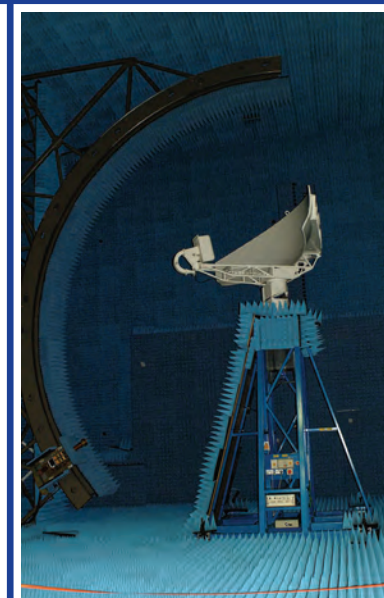

Over 50 years ago, our organization helped define the concept of microwave measurement with the introduction of the first antenna pattern recorder. From this beginning, we have compiled an impressive array of test and measurement technology firsts including:

- The first fully automated antenna measurement system
- The first automated commercial planar scanner
- The first commercially available compact range
- The first commercial spherical near-field measurement system

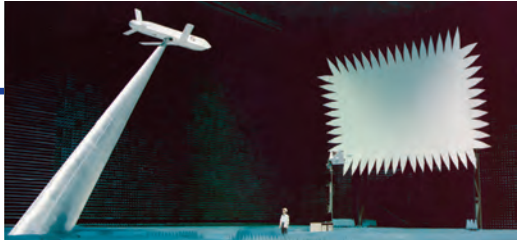

■ **Backed by
Superior Service**

- Engineering
- Installation
- Calibration
- Upgrades
- Repair
- Maintenance
- Range probing
- Training
- Testing

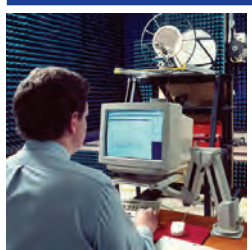

MI Technologies is the leading global supplier of RF and Microwave antenna products, systems and services.

We introduced the world to microwave antenna measurement systems and have continued to build on that legacy.

Today, our innovative solutions lead the industry in setting new standards of performance that pave the way to tomorrow's technology.

CAPABILITIES

- **Automated Test and Measurement Systems**
We have designed, manufactured, installed and qualified more automated test and measurement systems for antenna, RCS, and radome applications than any other provider. Our experience and technology leadership creates world class custom measurement systems for a variety of applications.
- **Complete System Design Capabilities**
MI Technologies' expertise in system upgrade, analysis and design includes host facilities, anechoic chambers, absorbing materials, microwave transmit and receive instruments, positioning, positioning control, and data acquisition and analysis.
- **End-to-end Program Management**
From cutting edge technical engineering to complex logistic coordination, our program management staff can coordinate and execute programs of all sizes with precision and confidence.
- **Mechanical Design**
Our mechanical engineering staff has a depth and breadth needed to design the ideal mechanical solution for the most challenging applications.
- **RF and Microwave Engineering**
From free-space propagation to bench top component qualification, our engineers are capable of analyzing and delivering broad frequency solutions that unlock the toughest RF and microwave design problems.
- **Software Engineering**
The MI Technologies MI-3000 Data Acquisition and Analysis Workstation already provides the broadest flexibility and configurability in the industry. The software engineers who built this industry-leading solution regularly apply their design expertise and application understanding to focused, custom software solutions.
- **Test Facility Design**
MI Technologies is one of the few organizations in the world that can evaluate, measure, and accommodate all potential environmental and operating effects. Then we have the experience to build the system that matches the true performance requirements.
- **Building Construction**
Based on decades of experience constructing test environments, MI Technologies has developed the processes and relationships with contractors worldwide to ensure building design and construction is finished efficiently and expertly.
- **Chamber Construction**
At MI Technologies, we know how to recognize and solve the wide variety of challenges in chamber construction, including internal propagation, external spectral noise, lighting needs, building and fire codes, entry and exit needs, and HVAC systems.

MICROWAVE MEASUREMENT SYSTEMS

Outdoor Far Field

Historically, one of the most basic antenna test systems has been the outdoor far field range. Where land and environmental requirements can be satisfied, the outdoor far field is still a convenient solution for a wide variety of antenna test applications over a wide frequency range.

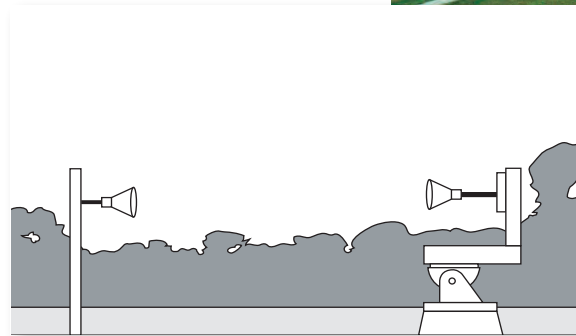

Indoor Far Field

Indoor far field measurements combine the straightforward test requirements of outdoor far field testing with the convenience and security of indoor operations. However, the breadth of frequencies and sizes of antennas that can be tested is ultimately limited by the size of the facility. This size is based on the range length criterion, which is defined as:

$$R \geq \frac{2D^2}{\lambda}$$

Where:

R = range length

D = aperture diameter of the antenna

λ = operating wavelength

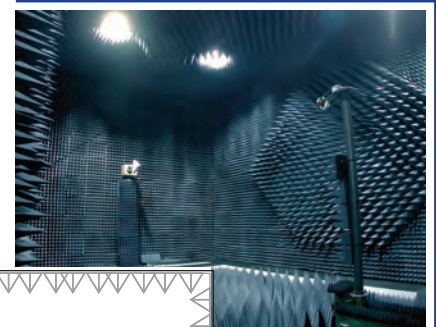
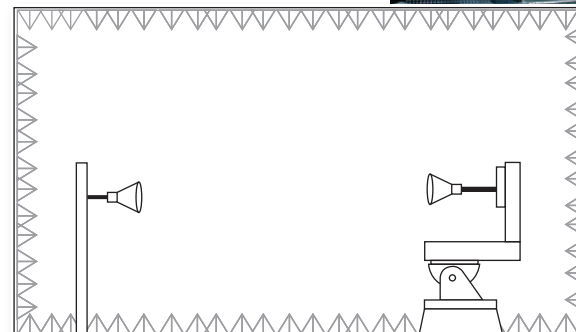

Compact Range

To compensate for range length limitations in indoor ranges, the compact range was developed. Compact ranges use a parabolic reflector to transform the spherical wave front from a nearby source feed into a planar wave front at the antenna under test. A compact range reflector essentially creates the conditions of a large outdoor far field range within a defined test zone in the chamber.

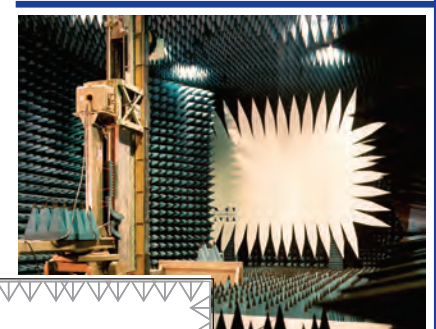
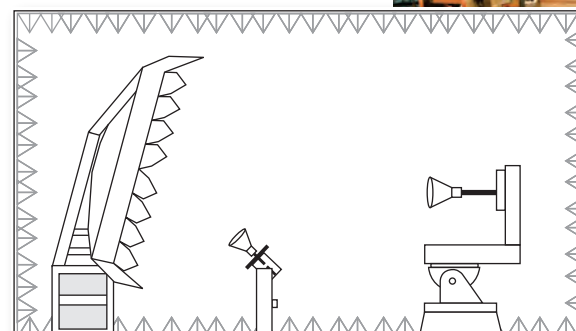

MICROWAVE MEASUREMENT SYSTEMS

Near Field Systems

While the compact range physically converts a spherical wavefront into a plane wavefront for testing, a near field range uses computer post-processing to make a similar conversion. By carefully mapping the electromagnetic field around the antenna under test in a defined coordinate system, a near field computational algorithm can be used to provide the antenna characteristics as if it had been measured in the far field.

Planar Near Field

Maps the antenna response in a planar (x,y) coordinate system. This mapping is especially convenient for directional antennas.

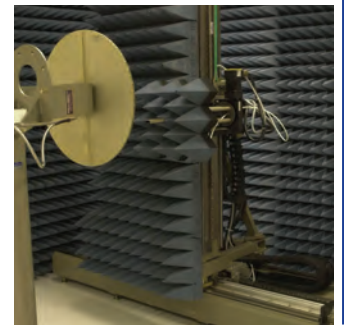
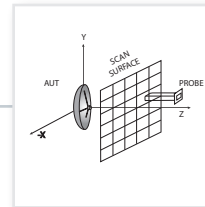

Cylindrical Near Field

Measures the antenna response in a cylindrical coordinate system. This provides 360 degree coverage of the antenna around its major axis.

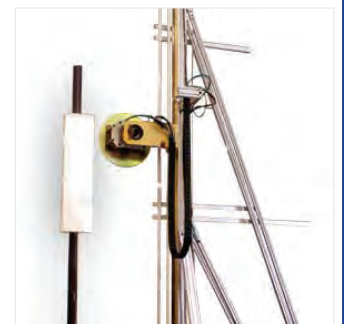
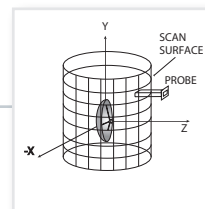

Spherical Near Field

Measures the antenna response in a spherical coordinate system. This provides complete degree coverage of the antenna from every direction.

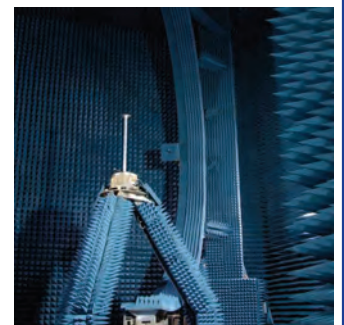
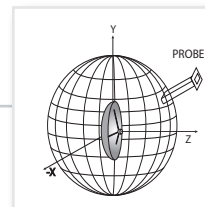

	Outdoor Far Field	Indoor Far Field	Compact Range	Planar Near Field	Cylindrical Near Field	Spherical Near Field
High Gain Antenna	Good	Adequate	Excellent	Excellent	Excellent	Excellent
Low Gain Antenna	Good	Good	Adequate	Adequate	Adequate	Good
Gain Measurement	Good	Good	Excellent	Excellent	Good	Excellent
Close Sidelobes	Good	Adequate	Excellent	Excellent	Excellent	Excellent
Far Sidelobes	Good	Adequate	Good	Poor	Good	Excellent
Axial Ratio	Good	Poor	Good	Excellent	Excellent	Excellent
Measurement Speed	Good	Excellent	Excellent	Good	Good	Adequate
Limitations	Weather, Range Length, Stray Signal	Range Length	AUT Size, Test Frequency	AUT Size, Test Frequency	AUT Size, Test Frequency	AUT Size, Test Frequency

PRODUCTS

SOFTWARE

MI-3000 Arena

Complex measurements can be automated and accelerated with the MI-3000 Arena. This software platform is dedicated to solving the unique challenges of microwave range operation and management. Take advantage of the modular analysis components, powerful plotting tools, standardized data management and broad range of instrument drivers. Its intuitive user interface, extensive scripting capability and broad data management functions give users the power and flexibility to productively solve the toughest measurement challenges.

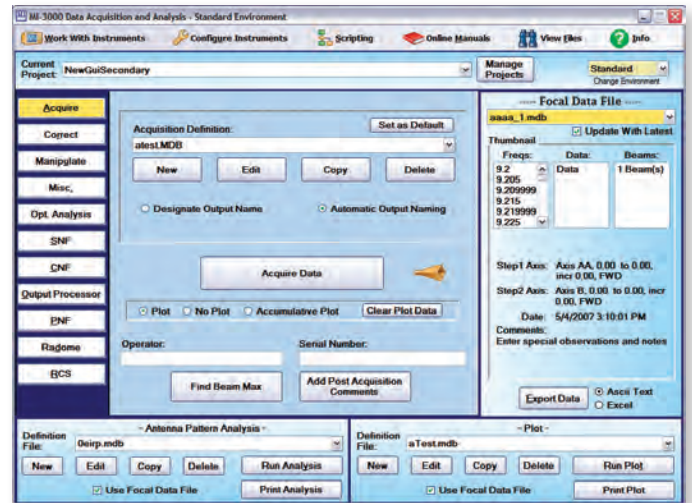
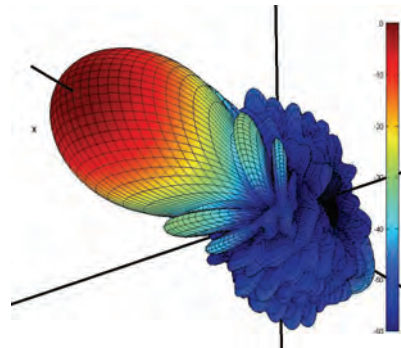

INSTRUMENTATION

MI-750 Advanced Technology Digital Receiver

Flexibility. Serviceability. Compatibility.

The MI-750 Digital Receiver has been designed with the latest technology to be the fastest system receiver in the industry. With measurement speeds of 4,000,000 samples/second and built-in data management features, the MI-750 has the throughput capacity to get detailed measurement results that earlier may have been prohibitively slow. Combined with this sampling performance, is a world-class RF design offering receiver sensitivity to -150dBm and enabling a high dynamic range of 135dB.



MI-3120 Family of Synthesized Signal Sources

Reduced Test Time. More Accurate Results.

MI Technologies' MI-3121 and MI-3122 Synthesized Signal Sources provide a fast, accurate and economical signal generation solution for a wide range of test and measurement applications.



Complete Suite of System Accessories

Standard gain horns, compact range feeds, dual polarized feeds, waveguide feeds, parabolic reflectors, waveguide adaptors, high frequency rotary joints, mixers, multipliers, switches and many other components are offered for a complete test solution.



PRODUCTS

POSITIONING

Positioning Systems

MI Technologies offers over 100 different positioning devices that can be combined to address a wide variety of multi-axis positioning applications. Combinations of azimuth, elevation, slides, masts, and polarization rotators are available to position devices up to 200 tons with precision and repeatability to a fraction of a degree.

Near Field Scanners

The MI-6910 Family of Planar Scanners provides a variety of planar near field scan lengths from 1 to 50 meters.

The MI-6850 Family of Spherical Arch scanners are ideal for high-precision spherical near field antenna measurements.

We often combine these near field scanning solutions with a stackup of MI Technologies' positioning products to build efficient and economical cylindrical and spherical near field measurement systems.

MI-55000 Azimuth/Elevation/Azimuth Positioners

MI-54000 Elevation/Azimuth Positioners

MI-53000 Azimuth/Elevation Positioners

MI-51000 Azimuth Positioners

MI-640 Linear Slides

MI-5600 Polarization Positioners
MI-6100 Rotary Positioners

MI-6500 Masts

MI-6400 Offset Arms

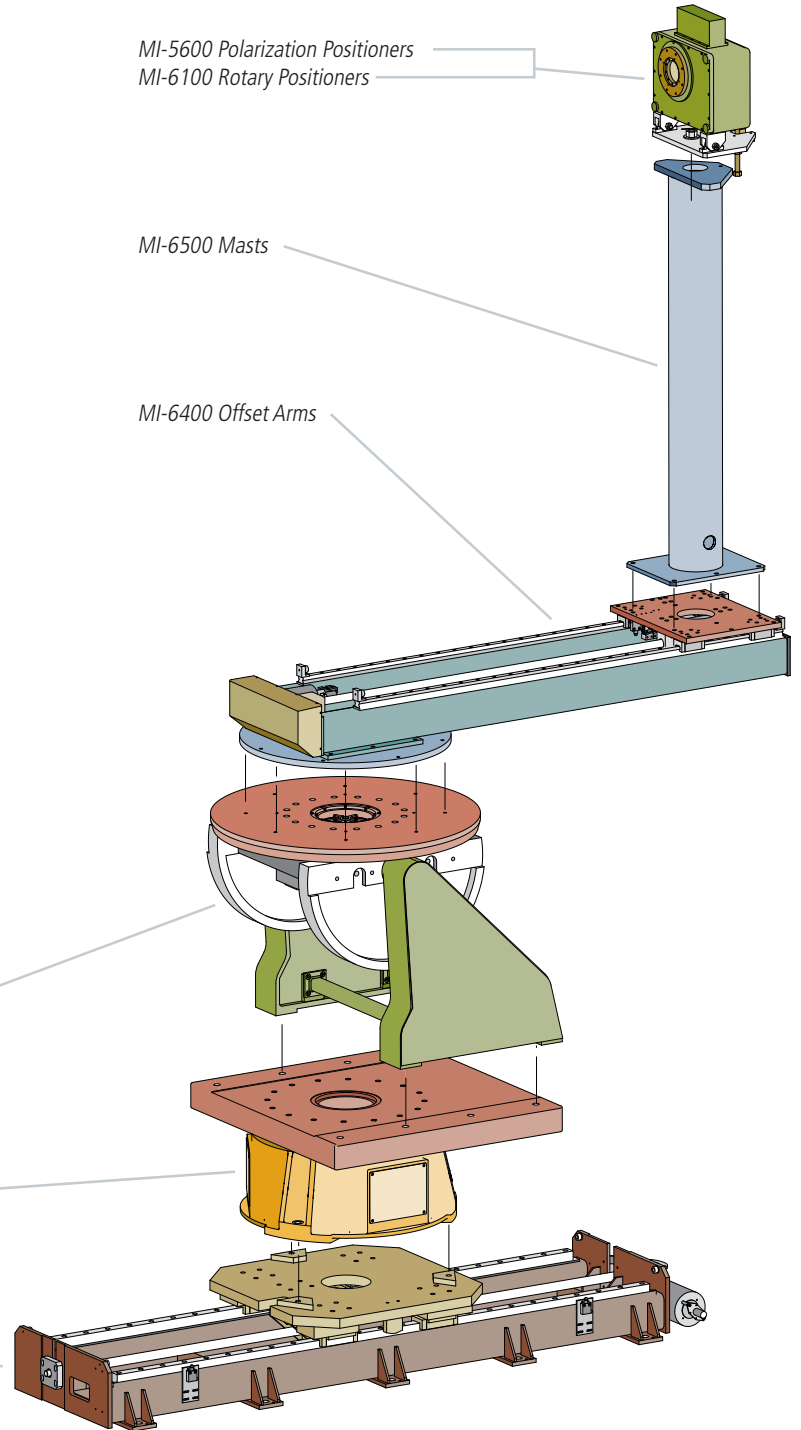

MI-4190 Position Controllers

The MI-4190 Family of Position Controllers offers solutions for nearly every motion control application – from precision placement and rotation of tools, targets or instruments in laboratories, test facilities or remote field locations – to complex, multi-axis positioners and scanners.

PUTTING IT ALL TOGETHER

■ POWERFUL

MI-350 Advanced Microwave Measurement

The MI-350 Advanced Microwave Measurement System is composed of several configurable MI Technologies products. These products are designed to be fundamental building blocks that enable the MI-350 to encompass the widest possible range of applications. The MI-350 measurement system consists of:

- MI-3000 Arena™ Data Acquisition and Analysis Software
- MI-750 Advanced Digital Receiver
- MI-710 Position Controllers
- MI-3121 Synthesized Signal Sources
- MI-788 Networked Acquisition Controller

The MI-350 Measurement System can be configured for a wide range of measurement applications, providing the user with a selection of far-field, compact range, and near-field systems. Specialty and custom applications for radome, RCS, component and wireless applications are also available. All of the major instruments in the MI-350 Advanced Microwave Measurement System are designed to coordinate both data and measurement control over Ethernet. This common interface provides economical flexibility with a worldwide standard to add configuration breadth and ease of use.



■ VARIETY

The Right Instruments from the Right Source

Because of the wide variety of measurement challenges and unique customer requirements, not all of our measurement solutions are built exclusively with products from MI Technologies. We regularly incorporate a variety of measurement equipment such as network analyzers, signal sources, spectrum analyzers or power meters. We have relationships with major test equipment providers such as:

Agilent Technologies
Anritsu
Rohde & Schwarz
National Instruments



■ GROW, ADAPT, RECONFIGURE

Start Small and Expand

MI Technologies systems and solutions are designed to accommodate a wide range of budgets, applications and performance requirements. Because of this, our systems have the ability to grow, adapt, and reconfigure with your growing business. For example, an indoor far field range can be upgraded to a planar near field range or cylindrical near field range. Planar and cylindrical near field systems can be enhanced to provide spherical measurement capability. And with MI Technologies, you can go beyond near field system optimization and use our industry leading experience to evolve your system across the entire spectrum of measurement applications.

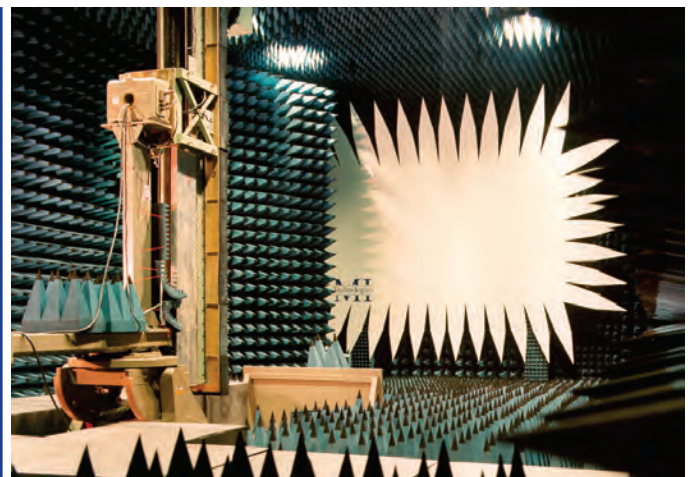

PUTTING IT ALL TOGETHER

REQUIREMENTS

How to Start Building a Test System

Free space microwave test systems are inherently complex, with significant and fundamental design variations depending on the application. One cannot simply purchase a network analyzer with a standard gain horn and expect to immediately make antenna measurements. Valid results can only be obtained by carefully integrating environmental solutions with instrumentation, position control systems and dedicated data analysis tools. Considerable time and expense can be saved by carefully considering the factors that most influence system configuration.



We recommend starting with the following list:

- Available facility space*
- Measurement speed*
- Device size and weight*
- Electrical size of device*
- Frequency range*
- Device mounting constraints*
- High vs. low gain*
- Narrow, fan or omni directional pattern*
- Sidelobe level and proximity to main lobe*
- Range of measured angles*
- Required gain accuracy*
- Required sidelobe characterization*
- Axial ratio*

Each of these factors combines to create tradeoffs and opportunities among the many different system designs available. The more that is known about them, the more quickly MI Technologies can offer the most efficient options that current measurement science has to offer.



SOLUTIONS

SERVICE AND SUPPORT

■ **Antenna and Radome Testing Services**

MI Technologies' two test ranges with measurement facilities come with our highly experienced engineering staff. We are available now to support your test needs.

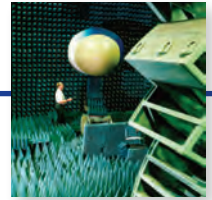

■ **Post Warranty Services**

MI Technologies' TechCare and TechCal plans ensure your range and components are operating at maximum efficiency while enabling your organization to apply the vast majority of its resources on testing and product development.



■ **Range Probe Services**

MI Technologies offers precision field probe measurements, probe data analysis and longitudinal pattern comparison testing to help ensure your range is operating properly.



■ **Precision Alignment Services**

Our service reduces your measurement time, required personnel, and costs associated with precise measurement and alignment of complex, heavy range equipment and surfaces.



■ **Range Relocation Service**

MI Technologies is the leader in range relocation services. We can ensure that all of the equipment is transported properly and can verify its performance at the new location.



■ **Refurbishment**

When your older equipment is not consistently working at its optimum or appears to be at the end of its lifecycle, MI Technologies can add years of useful value with our equipment refurbishment services.



■ **Software Maintenance**

MI Technologies' S-WareCare™ plans provide diagnostic and technical assistance, upgrades, access to telephone support with software experts at our customer support center and discounts on software training courses and related software products.



■ **Training and Certification**

MI Technologies offers training programs which ensure that your technical personnel are prepared to meet the changing needs of your test range investment.

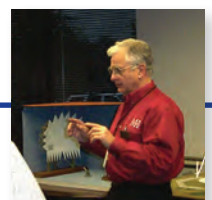

www.mi-technologies.com



1125 Satellite Blvd., Suite 100
Suwanee, Georgia 30024-4629 USA
1.800.854.3660
+1.678.475.8300
sales@mi-technologies.com