

AN ETHERNET BASED CONTROLLER FOR MANAGING COMPLEX ANTENNA MEASUREMENTS WITH A VECTOR NETWORK ANALYZER

Marion Baggett

mbaggett@mi-technologies.com

James Langston

jlangston@mi-technologies.com

MI Technologies, 1125 Satellite Boulevard, Suwanee, GA 30024 USA

Abstract

Vector Network Analyzers (VNA's) are finding increasing utilization in antenna measurement ranges. At the same time, complex measurement scenarios involving many data channels in the antenna under test along with integration to beam steering computers for phased array antennas require management of the data collection beyond the VNA. Traditional methods have added control cards in the measurement control computer, increasing software complexity and reducing measurement throughput. The MI-788 Networked Acquisition Controller is designed to manage the hardware handshakes between position controllers, external sources and VNA's, control up to 16 channels of multiplexed data from the antenna under test and/or interface with a beam steering computer. The MI-788 tremendously increases system throughput, particularly in these more complex measurement scenarios by removing real time data collection responsibilities from the measurement control computer. In addition, this unit makes all instrument communication Ethernet based, eliminating the spacing and operational limitations of GPIB based measurement systems. This paper will describe the operation of the MI-788 and demonstrate the increased measurement capabilities while using VNA's in antenna measurements.

Keywords: Instrumentation, measurements, software, range systems, network analyzers, system throughput

1 Introduction

Vector Network Analyzers (VNA) are being utilized on many antenna, radome and RCS ranges. In many cases, the VNA, a position controller and a control computer suffice to perform the desired

measurements. Modern VNA's are highly efficient in taking multiple frequency measurements and multiplexing several channels based on their internal switching capabilities [1]. However, in many cases, this simple system lacks efficiency in data throughput and for more complex scenarios, additional equipment such as external sources, multiplexers and/or beam steering computer interfaces are needed. This paper will discuss some conditions where additional control logic is needed for efficient measurements or to manage more complex systems. The MI-788 Networked Acquisition Controller is designed to provide this additional control logic when needed. For the purposes of this paper, "system throughput" is defined as the total set of measurements taken at a given antenna position per second. Measurements can include frequencies, VNA internal channels/traces, external channels, external sources and beam steering commands.

2 Simple VNA Measurement Systems

The simplest antenna measurement system is shown in Figure 1. The position controller generates a TTL trigger signal on reaching each desired position in a scan. The VNA performs the configured measurement sequence. If the VNA has the capability to buffer many sets of triggered data, the control computer essentially has to read position data from the position controller as the record increments are reached and periodically has to extract sets of data from the VNA. However, if the VNA cannot buffer data, the control computer must extract the data from the VNA before the next trigger arrives from the position controller, or the data will be lost. In this scenario, the software logic in the control computer is generally:

- Poll the position controller for the next desired position or wait for GPIB SRQ signal

- On recognition of reaching the desired position, read the position from the position controller
- Poll the VNA for measurement complete or wait for GPIB SRQ signal
- Read the VNA data

If the VNA and/or the position controller are on Ethernet links instead of GPIB interfaces, the control computer must poll to detect changing conditions instead of using the more efficient GPIB SRQ process [2]. It is apparent that considerable control computer software overhead will impact system throughput. If the VNA is doing a long and complex measurement, it will dominate system throughput. However, for simple single frequency, single channel measurements, the control computer overhead will dominate. Experiments performed with a non-buffering VNA, an MI-4193 Position Controller and a Windows based PC show that this scenario can yield as few as 10 position measurement sets per second. The VNA can be configured to collect measurements on up to 20 to 30 frequencies before the system throughput is impacted due to VNA operations. This shows a high level of computer overhead.

3 Complex VNA Measurement Systems

As the measurement system becomes more complex, straightforward control computer operations become more difficult. One scenario is for far field ranges or large near field ranges, an external signal source may be required. The usual method for fast frequency switching in this scenario is to cross connect the source external trigger and frequency locked signals with the VNA measurement/sweep done and external trigger lines [3]. This allows the VNA and source to handshake quickly, but the external trigger signal for the VNA is no longer available for triggering the VNA from the position controller. This adds more overhead at the control computer level. Some new VNA's, such as the Agilent PNA-X provide additional trigger signal lines to overcome this problem. If an external LO source is also required, such as for a remote mixing configuration, the traditional method is to daisy chain the two sources and the VNA trigger signals. This results in a frequency change requiring the tuning delays for both sources in series, doubling frequency switching time for the system.

Most modern top of the line VNA's provide a "configurable test set". This test set exposes two signal source outputs and two receivers to the outside world. In an antenna measurement scenario, the VNA could provide two transmit polarization signals or provide two receive paths, wholly under the VNA internal control, which is the most efficient method

from a throughput standpoint. However, if rotary axes are involved, dual cabling to transmit or receive locations may require expensive and less technically able dual rotary joints or cable service loops that then become susceptible to phase variation due to cable flexure. Modern antennas may require many signal channels beyond the capacity of the VNA alone. The VNA may be one of the more inexpensive VNA's where multi-port measurements are not possible internally. Other antennas may include a beam steering computer, which requires an interface, most likely with a handshake to hold off the measurements until the beam steering computer has completed its change. A possible solution to these issues is to add DIO interfaces to the control computer, but this adds even more burden on the high level computer software to manage these extra activities.

4 The MI-788 Networked Acquisition Controller

To address these issues, the MI-788 has been developed to provide control of devices outside the VNA and to remove any real time burden from the control computer. The major features of the MI-788 are:

- All trigger lines used by the position controller, the VNA and any external sources are managed by a Field Programmable Gate Array (FPGA). Latency for any trigger recognition or generation of a trigger is less than 10 μ seconds.
- A second FPGA is used to manage the high speed parallel interface to an MI-1795 or MI-1797 receiver if that receiver is included in the system and to read one or two ports of High Speed BCD (HSBCD) position data.
- The control processor for the MI-788 uses Linux as the operating system. This control processor interfaces to the outside world via Ethernet, including extracting data from the VNA.
- The control processor buffers large blocks of data for extraction by the control computer asynchronously to the real time measurement cycle. This removes real time burdens from the control computer.
- The MI-788 can manage up to 16 channels of data using MI-3320 family multiplexers.
- A 16 bit RS-422 interface is included for management of a beam steering computer or additional switches. A two wire handshake is included so that the beam steering computer can be alerted to a new control pattern and the next measurement can be held off until the beam steering computer

has completed its operations. Up to 1024 beam states are supported in a single acquisition.

- Trigger handshake lines are included to manage frequency switching for an external source and an external LO source when needed. When both sources are required, the frequency switching takes place in parallel instead of in series. Frequency lists up to 1024 frequencies are supported.
- Status indicators are provided on the MI-788 front panel to monitor record position triggers, receiver triggers, receiver measurement complete signals, and the external source trigger lines.
- The MI-788 can be configured and operated in a diagnostic mode via a built-in html interface.
- The MI-788 supports several of the popular VNA's and signal sources.

A picture of the MI-788 is shown in Figure 2.



Figure 2 The MI-788 Networked Acquisition Controller

5 The MI-788 in Measurement Systems

A system block diagram showing how the MI-788 fits into an antenna measurement system is shown in Figure 3. All trigger signals are TTL. In addition, an RS-422 interface for the external source trigger can be used when the external sources are located beyond the distance that normal BNC type cables can carry the trigger signals. Part of the MI-788 configuration includes identifying the optional devices such as external multiplexers. The unit is also configurable for the polarity and minimum width of all trigger signals to customize operations for instrument models used in a particular system. One or two of the MI-3320 family of channel switching multiplexers can be attached. A picture of the MI-788 rear panel is shown in Figure 4.



Figure 4 The MI-788 Networked Acquisition Controller Rear Panel

Returning to the simple measurement system of Figure 1, the same system with an MI-788 included is shown in Figure 5. For each position, the trigger from the position controller is recognized by the MI-788 and re-routed to the VNA with the polarity and width desired by the VNA. If HSBCD position data is desired, the current position is latched into the timing circuitry and its buffers at this time. The measurement complete signal from the VNA is then picked up by the MI-788 after the VNA completes its measurement. The timing circuitry notifies the high level processor in the unit that the measurement is complete. If the VNA does not buffer data, the high level processor in the MI-788 extracts the data from the VNA via Ethernet and buffers it along with any position data from the timing circuitry. This processor also notifies the timing circuitry that another position increment can be accepted. The data traffic from the VNA is over the LAN between the MI-788 and the VNA. If the VNA can buffer data internally, the MI-788 high level processor keeps count of the position increments and periodically extracts the data from the VNA as well as position data if required. The control computer requests buffered data periodically. These large blocks of data are very efficient over the Ethernet interface [2]. As was discussed above, the simple system of Figure 1 with a non-buffering VNA could perform around 10 position measurement sets per second with a minimal VNA measurement. The system of Figure 5 with the MI-788 has been tested in the same scenario and that system achieved over 100 position measurement sets per second, increasing system throughput by approximately an order of magnitude. Note that all data and configuration traffic for a VNA based system is over Ethernet, removing the GPIB cabling limitations or the requirements for GPIB/ENET converters or GPIB extenders. This provides significant system layout flexibility.

When external multiplexers and/or a beam steering interface are included, on each position trigger signal, the timing circuitry sets the proper multiplexer setting

and/or beam state before triggering the VNA. On each VNA measurement complete, the next external channel and/or beam state is set and the VNA triggered again. If the VNA can buffer data, the MI-788 adds less than 10 μ seconds of overhead for each channel change or beam state. If the VNA cannot buffer data, the MI-788 must read the VNA on each channel or beam state, adding less than one millisecond of overhead for switching management, not including the time to read the VNA.

When external sources are used, the MI-788 timing circuitry will cycle the sources through all frequencies in the acquisition set before notifying the high level processor to read the VNA. The high level processor then reads the entire frequency set as a group from the VNA.

If the receiver is an MI-1795 or MI-1797 Receiver, MI-788 operations and performance are equivalent to the MI-2097 Data Acquisition Co-Processor, which is the standard acquisition controller for a system based on MI Technologies receivers.

6 Summary

The MI-788 Networked Acquisition Controller has been developed to improve measurement throughput in simple VNA based systems, achieving an order of magnitude speed improvement in many measurement

scenarios. It also provides an integrating and control point for external sources, multiplexers or beam steering computers when using a VNA in an antenna measurement system.

7 References

- [1] Swanstrom, "Agilent's New PNA Receiver reduces Antenna/RCS Measurement Times", AMTA Symposium, 2004.
- [2] Baggett, "The Impact of Local Area Networks on Antenna Measurement Range Design", AMTA Symposium, 2006.
- [3] "Triggering the PNA Series Network Analyzer for Antenna Measurements", Agilent Application Note, Literature # 5988-9518EN, 2003.

Acknowledgements

The authors would like to express their appreciation for the efforts and support of the MI-788 design team; Jim Grattan, Richard Whatley, Steve Smith and Sudarshan Chakravarty, all of MI Technologies and Brad Ree of Programming Products, Inc.

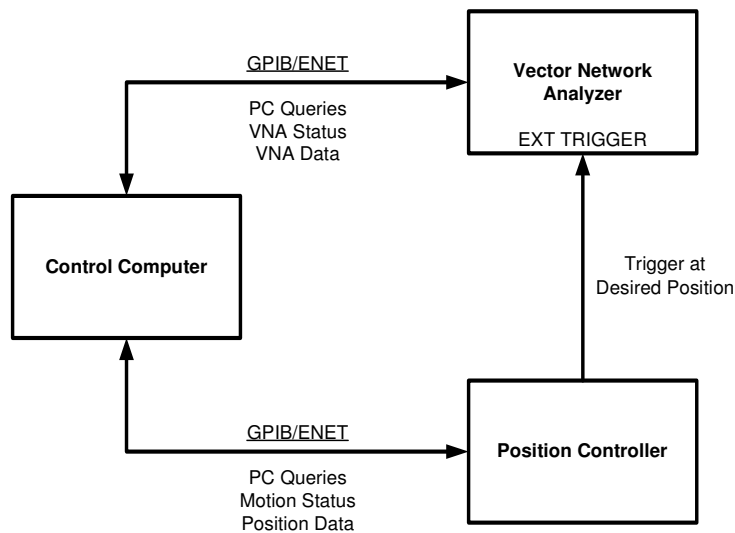

Figure 1 Simple VNA Based Measurement System

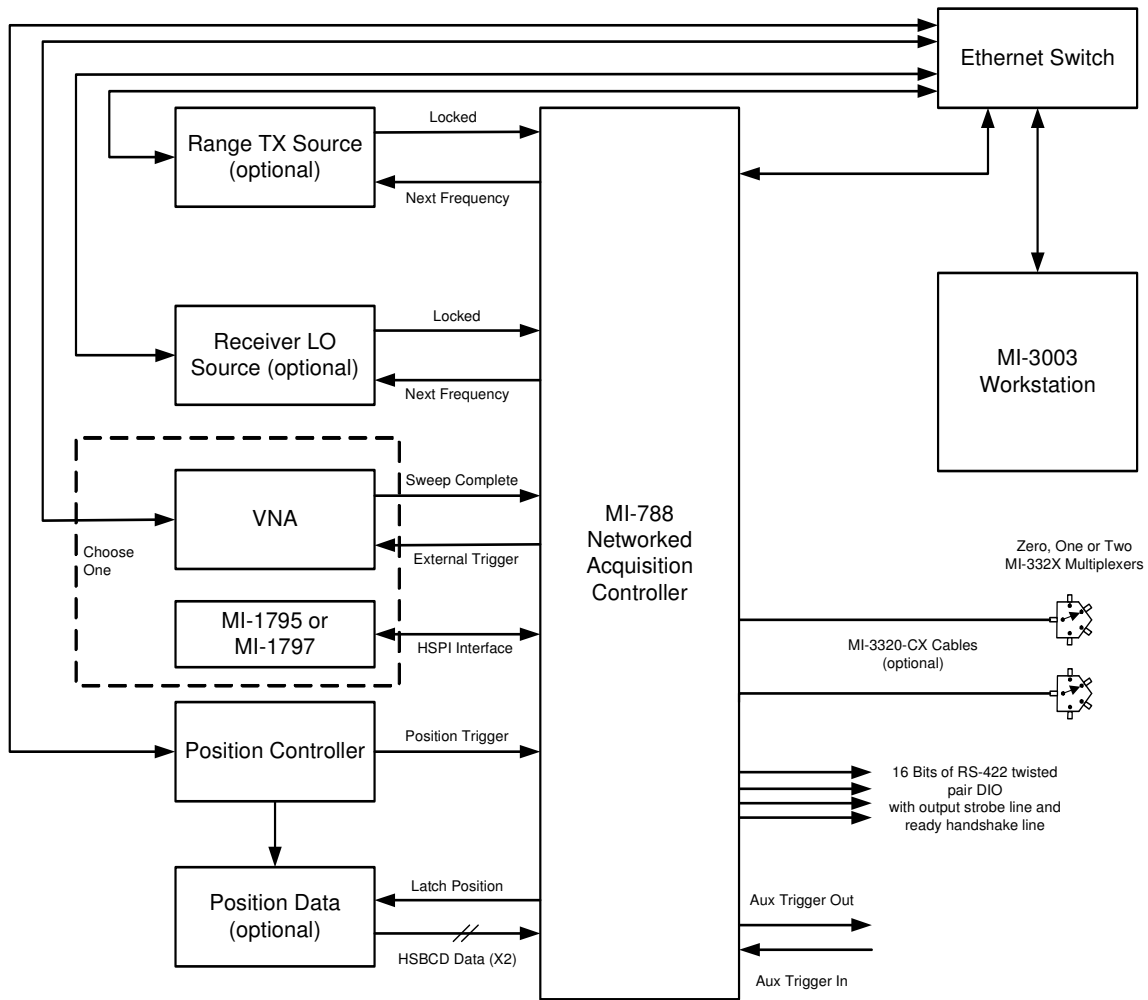

Figure 3 The MI-788 in a System

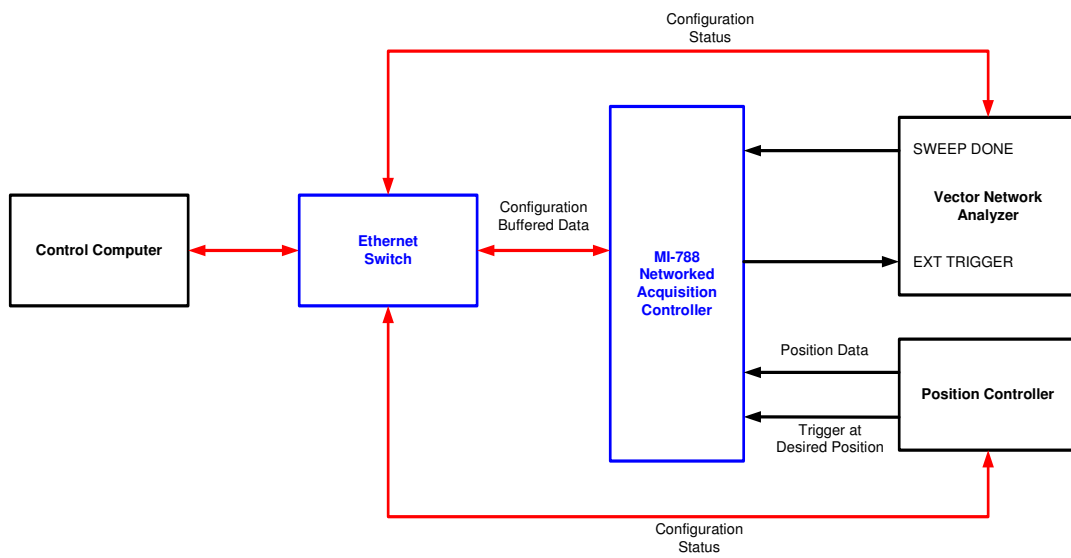

Figure 5 The Simple VNA based System with an MI-788 Included