

MI-3600

Cost-Effective Antenna Measurement Systems

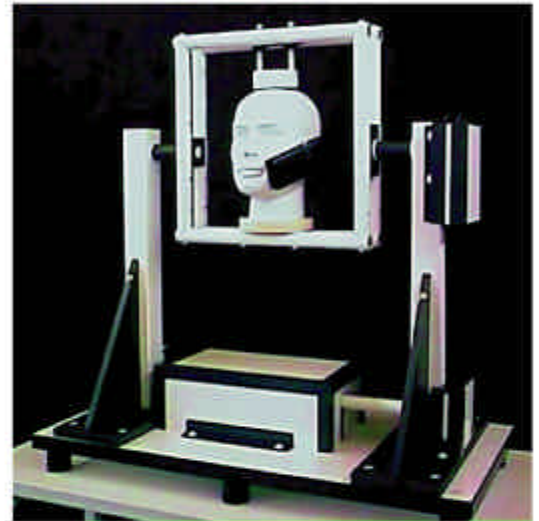

Near-Field Systems



Far-Field Systems

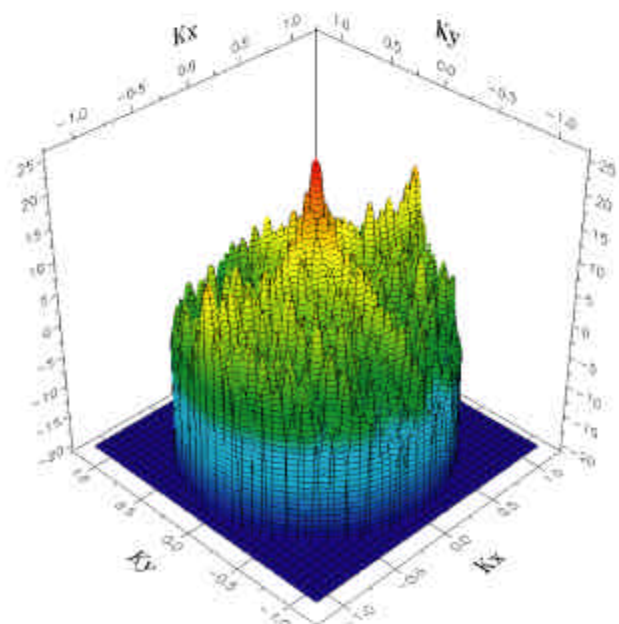

Software



Welcome to MI Technologies

MI Technologies is the leading supplier of RF and Microwave control, test and measurement products, systems, and services used for antenna, radome, RCS, component, EMC and EMI evaluation.

Our test and measurement solutions are used in a wide range of applications including wireless voice, data and video communications, navigation, direction/location finding, radar, tracking, and stealth technology. Our installations are used to characterize terrestrial, space and airborne systems and platforms by commercial, military, and government customers worldwide.

Technical Innovations from the Leading Supplier

MI Technologies has led the test and measurement industry for more than four decades with innovative products and break-through solutions for RF and microwave control, test and measurement applications. The business helped define the concept of microwave measurement through the introduction of the first antenna pattern recorder in the early 1950s. Over the years, the business has compiled an impressive array of technology firsts, including:

- the first automated commercial planar scanner
- the first compact range
- the first automated measurement system
- the first spherical near-field measurement system

And now we present the first high-performance and affordable test and measurement hardware and software products for the Wireless market.

Total Customer Satisfaction

MI Technologies' experience as a leading supplier of RF and Microwave control, test and measurement products helps us understand the challenges companies face today. Our measurement solutions help our customers maximize their potential and increase their products' competitive advantages by accelerating their time-to-market and reducing their development costs.

Our focus on total customer satisfaction includes three key areas: Turnkey System Design, Measurement Solutions, and Customer Support Services.

Turnkey System Design

The Company has fielded numerous turnkey systems for both satellite and wireless, ground-based and ship-borne installations. Our engineers listen, understand, and provide real world customer solutions every day.

Measurement Solutions

MI Technologies has installed standardized and specialized measurement and control products in facilities around the world for a wide range of testing applications. These systems have been designed to complement existing equipment to best meet our customers' requirements.

Customer Support Services

Our worldwide customer support provides a comprehensive, end-to-end portfolio of relevant services for new and established customers that provide a blanket of security over our customers' measurement requirement lifecycles. Our services help our customers maximize the performance and availability of their test and measurement deployments in the most cost-effective manner.

Table of Contents

MI-3600 Family Comparison Charts Page 3

MI-3600 Overview Page 5

Far-Field Measurement Systems

MI-3611 AMS Page 7

MI-3612 AMS Page 9

MI-3613 AMS Page 11

MI-3614 AMS Page 13

MI-3615 AMS Page 15

MI-3621 AMS Page 17

MI-3622 AMS Page 19

MI-3623 AMS Page 21

MI-3624 AMS Page 23

MI-3625 AMS Page 25

Near-Field Measurement Systems

MI-3630 Planar Near-Field System Page 27

MI-3640 Cylindrical Near-Field System Page 29

MI-3650 Spherical Near-Field System Page 31

Workstations

MI-3600 Family of Workstation Products Page 33

Customer Support

System and Product Lifecycle Commitment Page 35

Cost-Effective Far-Field Systems

Model	Receiver	Transmitter	Single-Axis	Dual-Axis	Features
MI-3611	Power Meter	Two Narrow Band Synthesizers*	X		See Chart Below
MI-3612	Spectrum Analyzer	Two Narrow Band Synthesizers*	X		See Chart Below
MI-3613	Vector Network Analyzer (VNA)	Embedded in VNA	X		500 to 3000 MHz continuous coverage
MI-3614	Power Meter	Synthesizer Source	X		500 to 2100 MHz continuous coverage
MI-3615	Vector Network Analyzer (VNA)	Embedded in VNA	X		500 to 6000 MHz continuous coverage
MI-3621	Power Meter	Two Narrow Band Synthesizers*		X	See Chart Below
MI-3622	Spectrum Analyzer	Two Narrow Band Synthesizers*		X	See Chart Below
MI-3623	Vector Network Analyzer (VNA)	Embedded in VNA		X	500 to 3000 MHz continuous coverage
MI-3624	Power Meter	Synthesizer Source		X	500 to 2100 MHz continuous coverage
MI-3625	Vector Network Analyzer (VNA)	Embedded in VNA		X	500 to 6000 MHz continuous coverage

**Frequency Bands Available for Narrow Band Synthesizers
(Models MI-3611, 3612, 3621, 3622)*

Software & Workstations

Model	Features
MI-3601	Control of single-axis positioning system
MI-3602	Control of dual-axis positioning system
MI-3603 P, C & S	Full featured support for planar (P), cylindrical (C) and spherical (S) near-field measurements

Transmitter Model	Frequency
MI-3161-8	500-800 MHz Range 100 kHz Step
MI-3161-9	800-1200 MHz Range 100 kHz Step
MI-3161-10	1000-1500 MHz Range 100 kHz Step
MI-3161-11	1500-2000 MHz Range 100 kHz Step
MI-3161-12	2000-2500 MHz Range 100 kHz Step

Cost-Effective Near-Field Systems

Specifications	MI-3630 Planar Near-Field System*	MI-3640 Cylindrical Near-Field System*	MI-3650 Spherical Near-Field System*
Measurement Area Horizontal by Vertical	MI-3630-3X3 3 ft X 3 ft MI-3630-6X6 6 ft X 6 ft MI-3630-8X8 8 ft X 8 ft MI-3630-10X10 10 ft X 10 ft	NA	NA
Vertical Scan Length	NA	MI-3640-6 6 ft MI-3640-8 8 ft MI-3640-10 10 ft	NA
Measurement Sphere Diameter	NA	NA	MI-3650-3 3 ft MI-3650-6 6 ft MI-3650-9 9 ft
DUT Weight Limit	NA	NA	40 lbs Max
Azimuth Positioner Vertical Weight Limit	NA	1,000 lbs Max	NA
Scanner Absorber	12 inch pyramidal	12 inch pyramidal	12 inch pyramidal
Probe	WR-430 open ended wave- guide with SMA transition	WR-430 open ended wave- guide with SMA transition	WR-430 open ended wave- guide with SMA transition
Probe Absorber	12 inch pyramidal	12 inch pyramidal	12 inch pyramidal
Probe Mount	Bracket permitting vertical and horizontal mounting of probe	Bracket permitting vertical and horizontal mounting of probe	Bracket permitting vertical and horizontal mounting of probe
RF Cables	Flexible 10 ft (3 m) with SMA (m-M) coaxial Connectors, DC to 18 GHz (4 each)	Flexible 10 ft (3 m) with SMA (m-M) coaxial Connectors, DC to 18 GHz (4 each)	Flexible 10 ft (3 m) with SMA (m-M) coaxial Connectors, DC to 18 GHz (4 each)
Rotary Joint	DC to 18 GHz for azimuth positioner	DC to 18 GHz for azimuth positioner	DC to 18 GHz (3 of each) for Phi, Theta and Polarization
Vector Network Analyzers Supported **	MI-1783, MI-1795, MI-1797, Anritsu MS4623B, Agilent 8510A/B/C, Agilent 8530A, Agilent 8753A/B/C/D/ E/ES	MI-1783, MI-1795, MI-1797, Anritsu MS4623B, Agilent 8510A/B/C, Agilent 8530A, Agilent 8753A/B/C/D/ E/ES	MI-1783, MI-1795, MI-1797, Anritsu MS4623B, Agilent 8510A/B/C, Agilent 8530A, Agilent 8753A/B/C/D/ E/ES
Operating Frequency Range	400 MHz to 18 GHz	400 MHz to 18 GHz	400 MHz to 18 GHz
Workstation and Software	MI-3603P system control, acquisition and Planar Near-field software	MI-3603C system control, acquisition and Cylindrical Near-field software	MI-3603S system control, acquisition and Spherical Near-field software
Power	115/250 VAC, 50/60 Hz, 5A, Single Phase	115/250 VAC, 50/60 Hz, 5A, Single Phase	115/250 VAC, 50/60 Hz, 5A, Single Phase

* L Band standard; other bands available

NA - Not Applicable

** Consult factory for current list of VNAs supported

Cost-Effective Test and Measurement Products

MI Technologies is proud to present the MI-3600 family of antenna measurement systems. The MI-3600 products are ideally suited to meet the needs of commercial wireless markets which include fixed and mobile voice and data communications antennas and devices.

The MI-3600 test and measurement family of products offers 10 far-field antenna pattern measurement systems with single and dual-axis configurations. The family also includes 10 near-field measurement systems.

The MI-3600 product family provides rapid, cost-effective measurements of traditional antenna performance such as pattern characteristics, gain, front-to-back ratios, and sidelobe levels. These measurements provide data to support system level testing, including Effective Isotropic Radiated Power (EIRP). The MI-3600 far-field product family covers the 500 MHz to 6 GHz frequency range with outdoor and indoor measurement configurations. The MI-3600 near-field products cover 400 MHz to 18 GHz for indoor ranges.

Some of the many wireless devices that can be tested with the MI-3600 systems include cellular and PCS pico, micro and macro site base station antennas for any air interface, embedded antenna elements, handsets (mobile phones, personal digital assistants, pocket PCs, GPS positioning units and pagers), laptop PCs, wireless LAN devices, Bluetooth devices, MMDS antennas, Inmarsat antennas, and automotive telematics devices.



Features of the MI-3600 systems include:

- Affordable and easy-to-use for design verification and production testing
- Accurate automated antenna pattern and system level measurements
- Extensive built-in analysis software to simplify pattern evaluation
- Pattern plotting in polar or rectangular format for single or multiple patterns
- Network connections to download data to other compatible analysis programs

Near-Field Systems

MI Technologies' new MI-3630 Planar, MI-3640 Cylindrical and MI-3650 Spherical near-field systems provide fast, precise scanning for fast, accurate measurements.

Far-Field Systems

The MI-3610 series provide single-axis far-field measurements, while the MI-3620 series provide dual-axis far-field measurements. Each system provides an integrated, cost-effective measurement solution that comes complete with software to control included test equipment. The clear advantages to the MI-3600 systems are their low cost and ease of use.

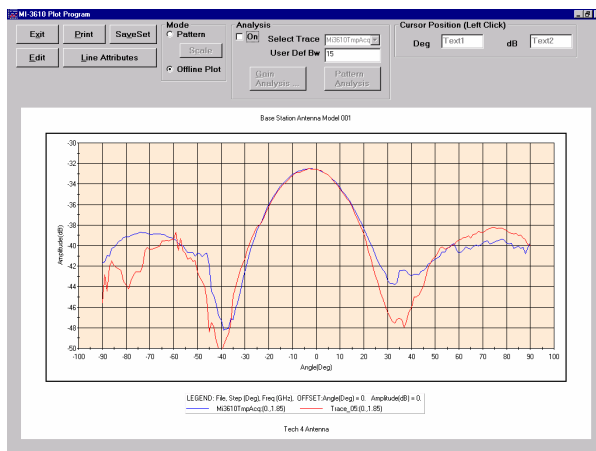

Analysis Results: Trace_01

Peak Value	-29.85
Peak Location	-52
Left Null Depth	-45.10
Left Null Location	-43.71
Left Side Lobe Level	-37.78
Left Side Lobe Location	-72.98
Right Null Depth	-43.68
Right Null Location	42.14
Right Side Lobe Level	-38.00
Right Side Lobe Location	66.06
3 dB Beam Width	36.62
10 dB Beam Width	-1.00
15.0 dB Beam Width	-1.00

* Units in dB or degrees

Software

The MI-3600 series of measurement software products provide consistent, reliable full-featured support for far-field and for planar, cylindrical and spherical near-field measurements.

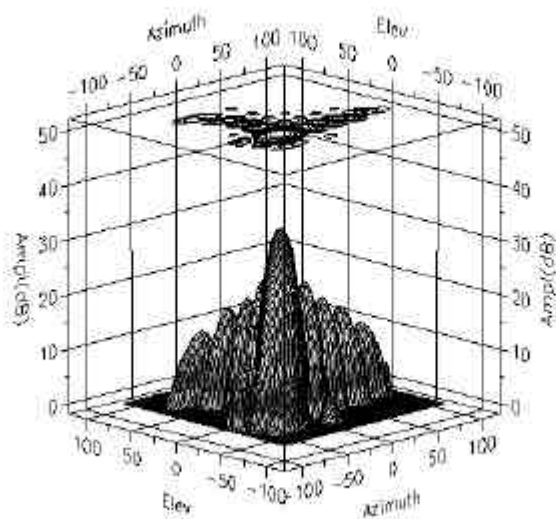

Far field obtained from planar near-field measurements

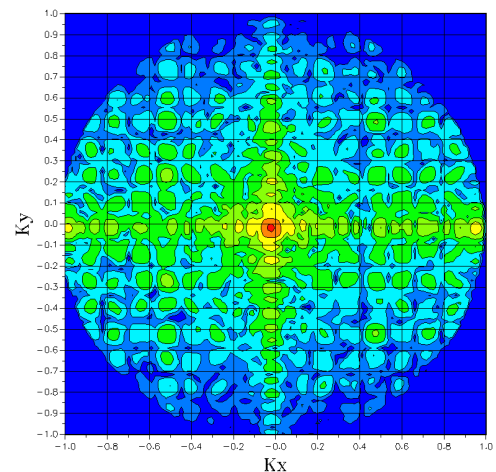

MI-3611 Far-Field System - Single-Axis / Power Meter

Key Features & Benefits

Two Bands within 500 MHz to 2.5 GHz

- Using a narrow band synthesizer to select any two bands within the 500 MHz to 2.5 GHz frequency range provides flexibility and wide coverage.
- Automated pattern measurements with flexible yet basic single-axis DUT positioner offer an economical control solution.
- A power meter presents the most economical receiver configuration.
- Pattern plotting in polar or rectangular format for single or multiple patterns offers the ultimate in flexible data presentation.
- Extensive analysis software is built-in to simplify pattern evaluation.
- Network connection provides means to easily download data for offline analysis.

Description

The MI-3611 is the lowest priced, single-axis far-field measurement system in the MI-3600 family designed for the Wireless market. Assembled to meet the needs of the most demanding test and measurement environments, the MI-3611 is a complete instrumentation system consisting of a workstation computer and software, azimuth positioner for rotating the Device-Under-Test (DUT), position controller, receiver, transmitter, and broadband linearly polarized log periodic source antenna. The distinguishing elements of the MI-3611 are the power meter receiver, narrow band synthesizer transmitter, and single-axis DUT positioner. The system provides superior ease of use that includes setup, test parameter provisioning, data acquisition, and data analysis. Using the workstation controller, an operator can select the transmit frequency from one of two narrow band synthesized signal sources and record the received signal from the broadband, highly accurate power meter receiver. Various options include standard gain antennas for calibration, masts for the source antenna and the DUT positioner, longer signal and control cables and absorber. The acronym CFE in the illustration below refers to Customer Furnished Equipment.

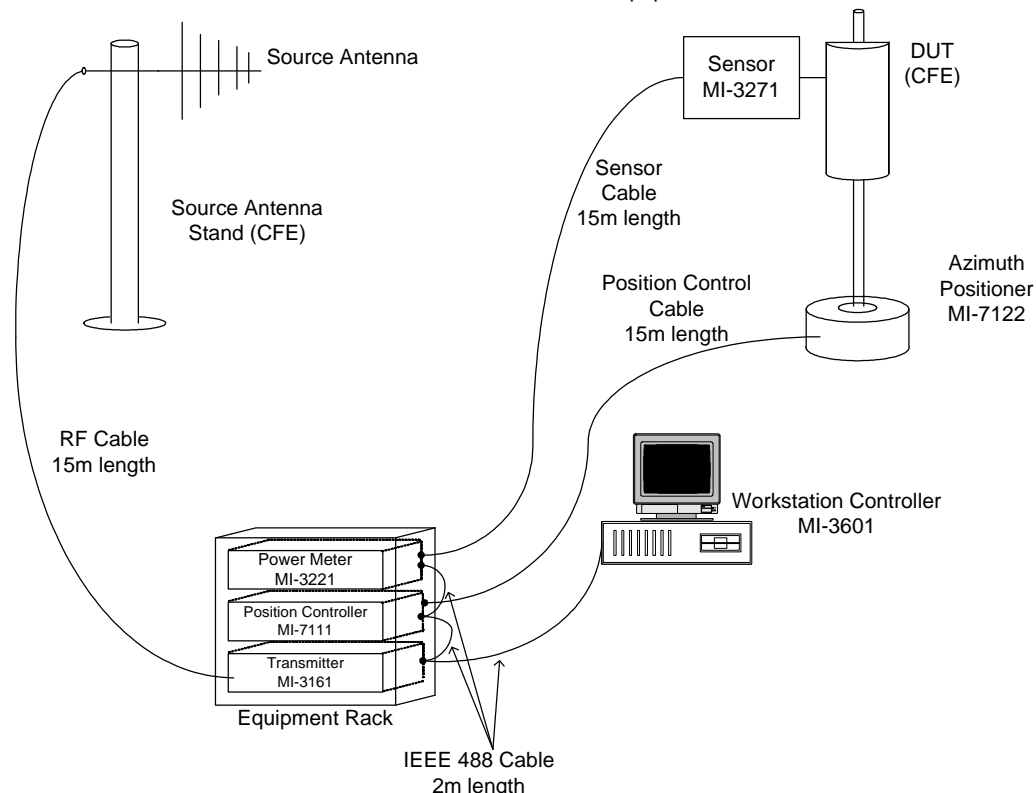

MI-3611 Specifications

System Workstation:

- MI-3601 workstation includes a computer, monitor, keyboard, mouse, color printer, ethernet card, and IEEE card
- Data acquisition and analysis software provides:
 - ▲ Automatic calculation of beam width, beam peak, location and depth of nulls, location and level of side-lobes, and gain
 - ▲ Polar or rectangular format plots

Signal Source:

- MI-3161 Narrow Band Synthesizer
- Two bands may be selected from the following: 500 to 800 MHz; 800 to 1,200 MHz; 1,000 to 1,500 MHz; 1,500 to 2,000 MHz; and 2,000 to 2,500 MHz
- Power: 10 dBm max

Receiver:

- MI-3221 Power Meter with sensor
 - ▲ Input power: -70 to +30 dBm
(RF filtering of the receiver may be required, depending on your application)

Positioner:

- MI-7122 Azimuth Positioner
 - ▲ Diameter: 0.8 meter (31.5 inches)
 - ▲ Vertical load handling: 75 kg (165 lbs)
 - ▲ Speed: 0.3 to 3 rpm
 - ▲ Rotation: ± 200 degrees
 - ▲ Angular accuracy: 0.5 degrees

Position Controller:

- MI-7111 single axis, IEEE 488 based

Source Antenna:

- Linearly polarized, log periodic

Cables:

- 15-meter cables are provided to support equipment separation

Options:

- Standard gain antennas
- Source antenna masts
- DUT masts
- Absorber
- Longer cables
- Contact factory for alternate configurations



MI-3221 Power Meter with Sensor

MI-3612 Far-Field System - Single-Axis / Spectrum Analyzer

Key Features & Benefits

Two Bands within 500 MHz to 2.5 GHz

- Using a narrow band synthesizer to select any two bands within the 500 MHz to 2.5 GHz frequency range provides flexibility and wide coverage.
- Automated pattern measurements with flexible yet basic single-axis DUT positioner offer an economical control solution.
- A spectrum analyzer receiver provides superior RF selectivity.
- Pattern plotting in polar or rectangular format for single or multiple patterns offers the ultimate in flexible data presentation.
- Extensive analysis software is built-in to simplify pattern evaluation.
- Network connection provides means to easily download data for offline analysis.

Description

The MI-3612 is a mid-range, single-axis far-field measurement system in the MI-3600 family designed for the Wireless market. Assembled to meet the needs of the most demanding test and measurement environments, the MI-3612 is a complete instrumentation system, consisting of a workstation computer and software, azimuth positioner for rotating the Device-Under-Test (DUT), position controller, receiver, transmitter, and broadband linearly polarized log periodic source antenna. The distinguishing elements of the MI-3612 are the spectrum analyzer receiver, narrow band synthesizer transmitter, and single-axis DUT positioner. The system provides superior ease of use that includes setup, test parameter provisioning, data acquisition, and data analysis. Using the workstation controller, an operator can select the frequency from one of two narrow band synthesized signal sources and record the received signal from the broadband, highly accurate spectrum analyzer receiver. Various options include standard gain antennas for calibration, masts for the source antenna and the DUT positioner, longer signal and control cables and absorber. The acronym CFE in the illustration below refers to Customer Furnished Equipment.

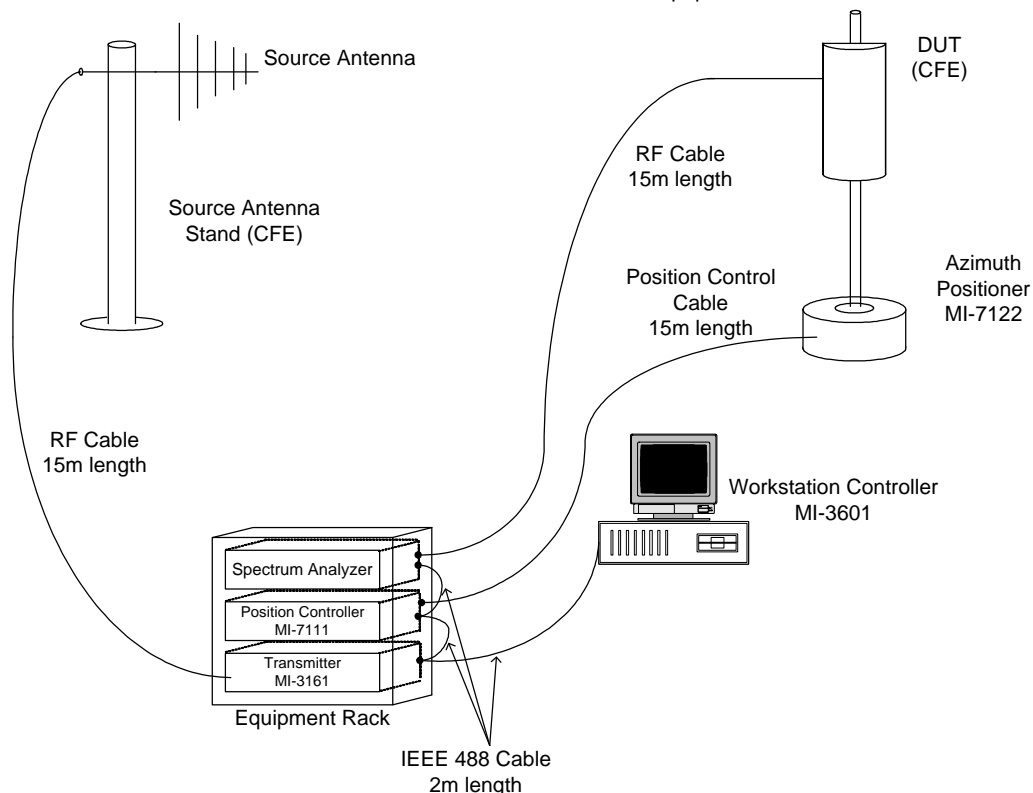

MI-3612 Specifications

System Workstation:

- MI-3601 workstation includes a computer, monitor, keyboard, mouse, color printer, ethernet card, and IEEE card
- Data acquisition and analysis software provides:
 - ▲ Automatic calculation of beam width, beam peak, location and depth of nulls, location and level of side-lobes, and gain
 - ▲ Polar or rectangular format plots

Signal Source:

- MI-3161 Narrow Band Synthesizer
- Two bands may be selected from the following: 500 to 800 MHz; 800 to 1,200 MHz; 1,000 to 1,500 MHz; 1,500 to 2,000 MHz; and 2,000 to 2,500 MHz
- Power: 10 dBm max

Receiver:

- Spectrum Analyzer
 - 3 dB Resolution Bandwidth
 - Dynamic Range: 110 dB (narrowband)
 - Input Power: -10 dBm max
- (MI Technologies has partnered with the Anritsu Company for the supply of vector network analyzers, spectrum analyzers and other products for use in the MI-3600 family of antenna test and measurement systems)

Positioner:

- MI-7122 Azimuth Positioner
 - ▲ Diameter: 0.8 meter (31.5 inches)
 - ▲ Vertical load handling: 75 kg (165 lbs)
 - ▲ Speed: 0.3 to 3 rpm
 - ▲ Rotation: ± 200 degrees
 - ▲ Angular accuracy: 0.5 degrees

Position Controller:

- MI-7111 single-axis, IEEE 488 based

Source Antenna:

- Linearly polarized, log periodic

Cables:

- 15-meter cables are provided to support equipment separation

Options:

- Standard gain antennas
- Source antenna masts
- DUT masts
- Absorber
- Longer cables
- Contact factory for alternate configurations



Spectrum Analyzer

MI-3613 Far-Field System - Single-Axis / Vector Network Analyzer

Key Features & Benefits

500 MHz to 3.0 GHz

- Using a vector network analyzer over the 500 MHz to 3.0 GHz frequency band provides increased flexibility and frequency control.
- Automated pattern measurements with flexible yet basic single-axis DUT positioner offer an economical control solution.
- Extensive analysis software is built-in to simplify pattern evaluation.
- A vector network analyzer provides superior broadband measurements with high dynamic range and increased frequency resolution.
- Pattern plotting in polar or rectangular format for single or multiple patterns offers the ultimate in flexible data presentation.
- Network connection provides means to easily download data for offline analysis.

Description

The MI-3613 is a high-end, single-axis far-field measurement system in the MI-3600 family designed for the Wireless market. Assembled to meet the needs of the most demanding test and measurement environments, the MI-3613 is a complete instrumentation system, consisting of a workstation computer and software, azimuth positioner for rotating the Device-Under-Test (DUT), position controller, vector network analyzer, and broadband linearly polarized log periodic source antenna. The distinguishing elements of the MI-3613 are the network analyzer, which combines a broadband receiver with a broadband transmitter with coverage to 3.0 GHz, and single-axis DUT positioner. The system provides superior ease of use that includes setup, test parameter provisioning, data acquisition, and data analysis. Using the workstation controller, an operator can select the transmit frequencies of operation and record the received signal from the broadband, highly accurate vector network analyzer. Various options include standard gain antennas for calibration, masts for the source antenna and the DUT positioner, longer signal and control cables and absorber. The acronym CFE in the illustration below refers to Customer Furnished Equipment.

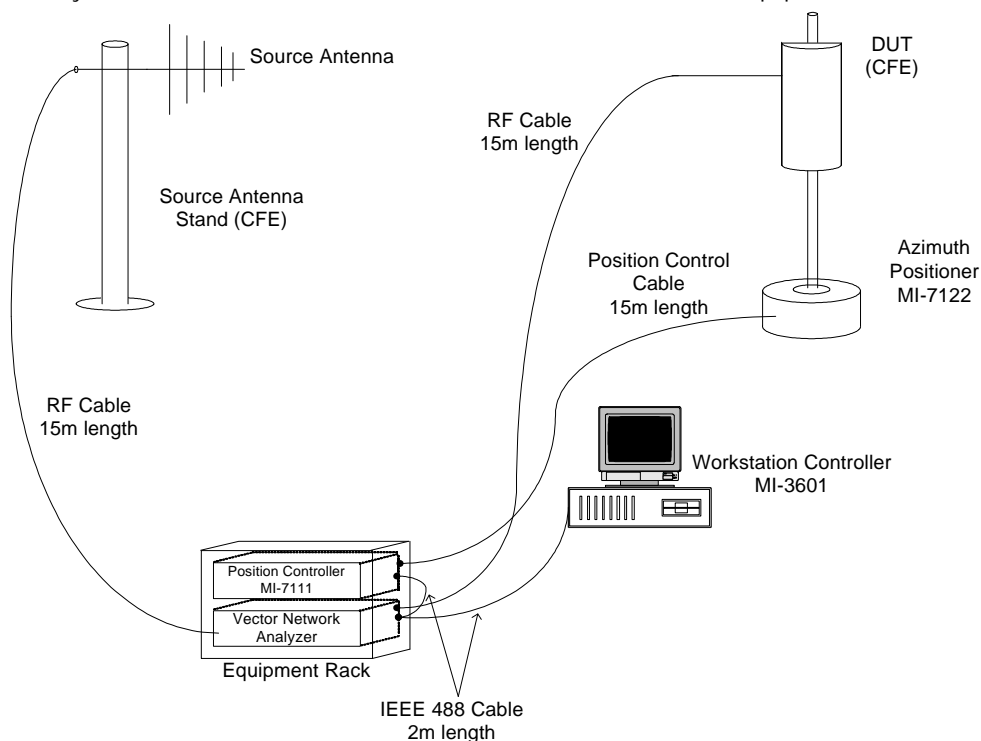

MI-3613 Specifications

System Workstation:

- MI-3601 workstation includes a computer, monitor, keyboard, mouse, color printer, ethernet card, and IEEE card
- Data acquisition and analysis software provides:
 - ▲ Automatic calculation of beam width, beam peak, location and depth of nulls, location and level of side-lobes, and gain
 - ▲ Polar or rectangular format plots

Receiver and Signal Source:

- Vector network analyzer
 - Frequency resolution: 1 Hz
 - System dynamic range: 100 dB
 - Input impedance: 50 ohms
 - Input power: 10 dBm max
- (MI Technologies has partnered with the Anritsu Company for the supply of vector network analyzers, spectrum analyzers and other products for use in the MI-3600 family of antenna test and measurement systems)

Positioner:

- MI-7122 Azimuth Positioner
 - ▲ Diameter: 0.8 meter (31.5 inches)
 - ▲ Vertical load handling: 75 kg (165 lbs)
 - ▲ Speed: 0.3 to 3 rpm
 - ▲ Rotation: ± 200 degrees
 - ▲ Angular accuracy: 0.5 degrees

Position Controller:

- MI-7111 single axis, IEEE 488 based

Source Antenna:

- Linearly polarized, log periodic

Cables:

- 15-meter cables are provided to support equipment separation

Options:

- Standard gain antennas
- Source antenna masts
- DUT masts
- Absorber
- Longer cables
- Contact factory for alternate configurations



Vector Network Analyzer

MI-3614 Far-Field System - Single-Axis / Synthesizer Source

Key Features & Benefits

500 MHz to 2.1 GHz

- Using a synthesized source transmitter over the 500 MHz to 2.1 GHz frequency range provides flexibility and wide coverage.
- Automated pattern measurements with flexible yet basic single-axis DUT positioner offer an economical control solution.
- A power meter presents the most economical receiver configuration.
- Pattern plotting in polar or rectangular format for single or multiple patterns offers the ultimate in flexible data presentation.
- Extensive analysis software is built-in to simplify pattern evaluation.
- Network connection provides means to easily download data for offline analysis.

Description

The MI-3614 is a mid-range, single-axis far-field measurement system in the MI-3600 family designed for the Wireless market. Assembled to meet the needs of the most demanding test and measurement environments, the MI-3614 is a complete instrumentation system consisting of a workstation computer and software, azimuth positioner for rotating the Device-Under-Test (DUT), position controller, receiver, transmitter, and broadband linearly polarized log periodic source antenna. The distinguishing elements of the MI-3614 are the power meter receiver, broadband synthesized source transmitter, and single-axis DUT positioner. The system provides superior ease of use that includes setup, test parameter provisioning, data acquisition, and data analysis. Using the workstation controller, an operator can select the operating frequencies from the synthesized source transmitter and record the received signal from the broadband, highly accurate power meter receiver. Various options include standard gain antennas for calibration, masts for the source antenna and the DUT positioner, longer signal and control cables and absorber. The acronym CFE in the illustration below refers to Customer Furnished Equipment.

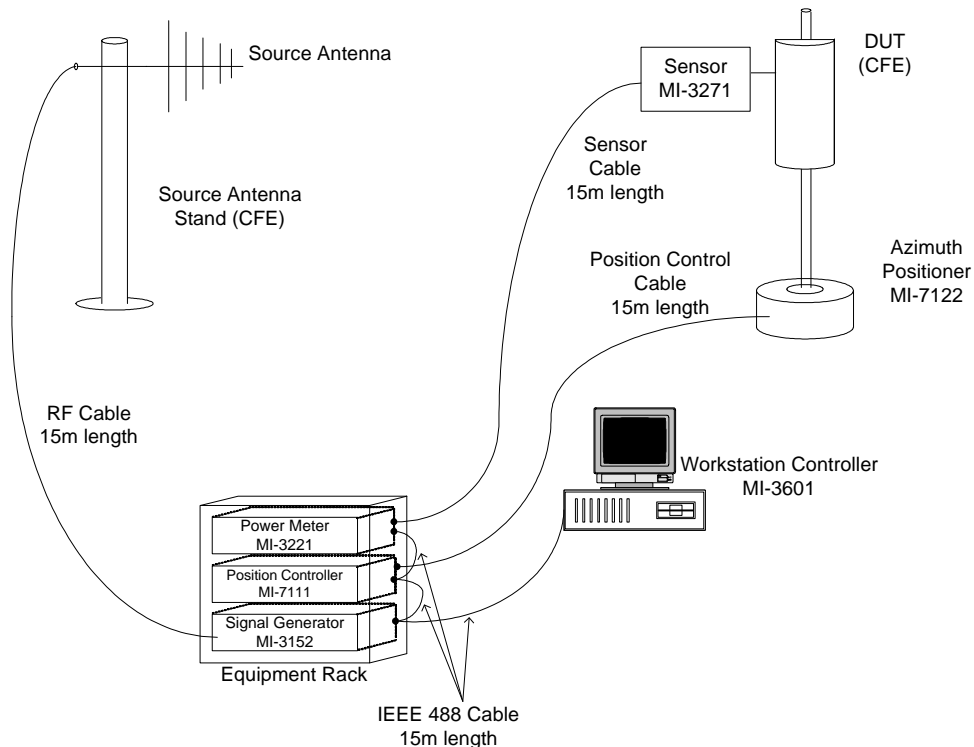

MI-3614 Specifications

System Workstation:

- MI-3601 workstation includes a computer, monitor, keyboard, mouse, color printer, ethernet card, and IEEE card
- Data acquisition and analysis software provides:
 - ▲ Automatic calculation of beam width, beam peak, location and depth of nulls, location and level of side-lobes, and gain
 - ▲ Polar or rectangular format plots

Signal Source:

- MI-3152 Signal Generator
- Power: 10 dBm max

Receiver:

- MI-3221 Power Meter with sensor
 - ▲ Input power: -70 to +30 dBm
(RF filtering of the receiver may be required, depending on your application)

Positioner:

- MI-7122 Azimuth Positioner
 - ▲ Diameter: 0.8 meter (31.5 inches)
 - ▲ Vertical load handling: 75 kg (165 lbs)
 - ▲ Speed: 0.3 to 3 rpm
 - ▲ Rotation: ± 200 degrees
 - ▲ Angular accuracy: 0.5 degrees

Position Controller:

- MI-7111 single-axis, IEEE 488 based

Source Antenna:

- Linearly polarized, log periodic

Cables:

- 15-meter cables are provided to support equipment separation

Options:

- Standard gain antennas
- Source antenna masts
- DUT masts
- Absorber
- Longer cables
- Contact factory for alternate configurations



MI-3152 Signal Generator

MI-3615 Far-Field System - Single-Axis / Vector Network Analyzer

Key Features & Benefits

500 MHz to 6.0 GHz

- Using a vector network analyzer over the extended frequency range of 500 MHz to 6.0 GHz band provides increased flexibility and frequency control.
- Automated pattern measurements with flexible yet basic single-axis DUT positioner offer an economical control solution.
- Extensive analysis software is built-in to simplify pattern evaluation.
- A vector network analyzer provides superior broadband measurements with high dynamic range and increased frequency resolution.
- Pattern plotting in polar or rectangular format for single or multiple patterns offers the ultimate in flexible data presentation.
- Network connection provides means to easily download data for offline analysis.

Description

The MI-3615 is a high-end, single-axis far-field measurement system in the MI-3600 family designed for the Wireless market. Assembled to meet the needs of the most demanding test and measurement environments, the MI-3615 is a complete instrumentation system consisting of a workstation computer and software, azimuth positioner for rotating the Device-Under-Test (DUT), position controller, network analyzer, and broadband linearly polarized log periodic source antenna. The distinguishing elements of the MI-3615 are the network analyzer which combines a broadband receiver with a broadband transmitter with coverage from 500 MHz to 6.0 GHz and single-axis DUT positioner. The system provides superior ease of use that includes setup, test parameter provisioning, data acquisition, and data analysis. Using the workstation controller, an operator can select the transmit frequencies of operation and record the received signal from the broadband, highly accurate vector network analyzer. Various options include standard gain antennas for calibration, masts for the source antenna and the DUT positioner, longer signal and control cables and absorber. The acronym CFE in the illustration below refers to Customer Furnished Equipment.

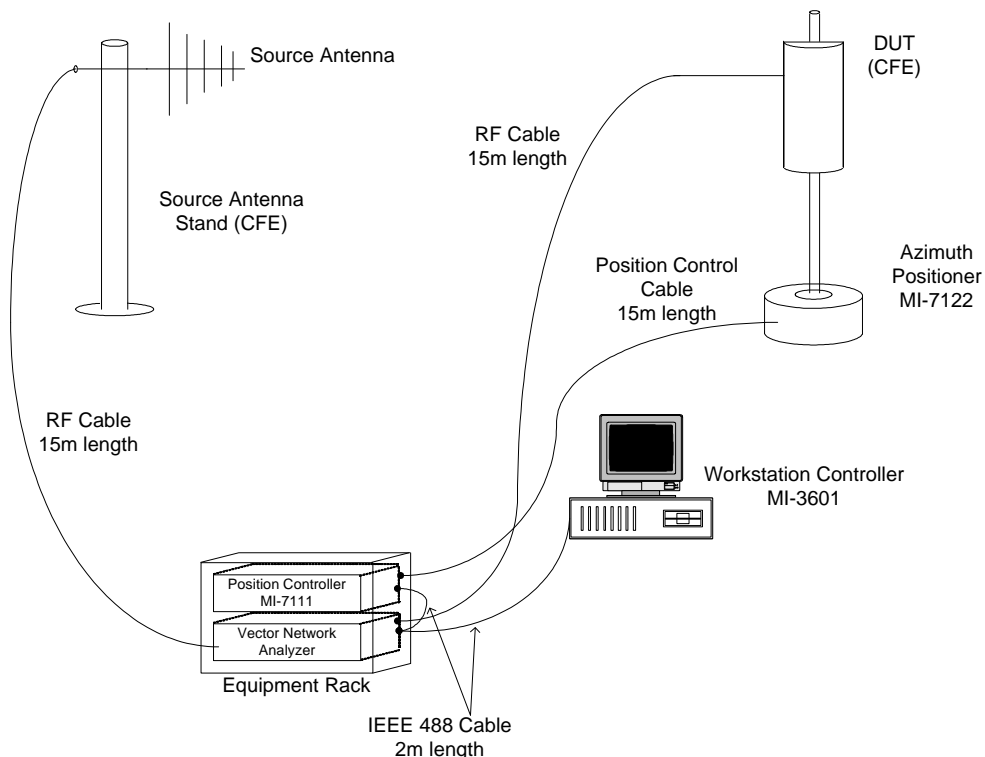

MI-3615 Specifications

System Workstation:

- MI-3601 workstation includes a computer, monitor, keyboard, mouse, color printer, ethernet card, and IEEE card
- Data acquisition and analysis software provides:
 - ▲ Automatic calculation of beam width, beam peak, location and depth of nulls, location and level of side-lobes, and gain
 - ▲ Polar or rectangular format plots

Receiver and Signal Source:

- Vector network analyzer
 - Dynamic range: 100 dB
 - Input impedance: 50 ohms
 - Source power: 5 dBm max
- (MI Technologies has partnered with the Anritsu Company for the supply of vector network analyzers, spectrum analyzers and other products for use in the MI-3600 family of antenna test and measurement systems)

Positioner:

- MI-7122 Azimuth Positioner
 - ▲ Diameter: 0.8 meter (31.5 inches)
 - ▲ Vertical load handling: 75 kg (165 lbs)
 - ▲ Speed: 0.3 to 3 rpm
 - ▲ Rotation: ± 200 degrees
 - ▲ Angular accuracy: 0.5 degrees

Position Controller:

- MI-7111 single-axis, IEEE 488 based

Source Antenna:

- Linearly polarized, log periodic

Cables:

- 15-meter cables are provided to support equipment separation

Options:

- Standard gain antennas
- Source antenna masts
- DUT masts
- Absorber
- Longer cables
- Contact factory for alternate configurations



Azimuth Positioner

MI-3621 Far-Field System - Dual-Axis / Power Meter

Key Features & Benefits

- Using a narrow band synthesizer to select any two bands within 500 MHz to 2.5 GHz frequency range provide flexibility and wide coverage.
- Network connection provides means to easily download data for offline analysis.
- A power meter presents the most economical receiver configuration.
- Extensive analysis software is built-in to simplify pattern evaluation.

Two Bands within 500 MHz to 2.5 GHz

- Automated dual-axis pattern measurements offer maximum flexibility and control with an advanced yet economical DUT positioner.
- Dielectric elevation positioner produces low perturbations to the measurements.
- Pattern plotting in polar or rectangular format for single or multiple patterns offers the ultimate in flexible data presentation.

Description

The MI-3621 is the lowest priced, dual-axis far-field measurement system in the MI-3600 family designed for the Wireless market. Assembled to meet the needs of the most demanding test and measurement environments, the MI-3621 is a complete instrumentation system consisting of a workstation computer and software, dual-axis positioner with combined azimuth and elevation angle control for rotating the Device-Under-Test (DUT), position controller, receiver, transmitter, and broadband linearly polarized log periodic source antenna. The distinguishing elements of the MI-3621 are the power meter receiver, narrow band synthesizer transmitter, and dual-axis DUT positioner. The system provides superior ease of use that includes setup, test parameter provisioning, data acquisition, and data analysis. Using the workstation controller, an operator can select the transmit frequency from one of two narrow band synthesized signal sources and record the received signal from the broadband, highly accurate power meter receiver. Various options include standard gain antennas for calibration, masts for the source antenna and the DUT positioner, longer signal and control cables and absorber. The acronym CFE in the illustration below refers to Customer Furnished Equipment.

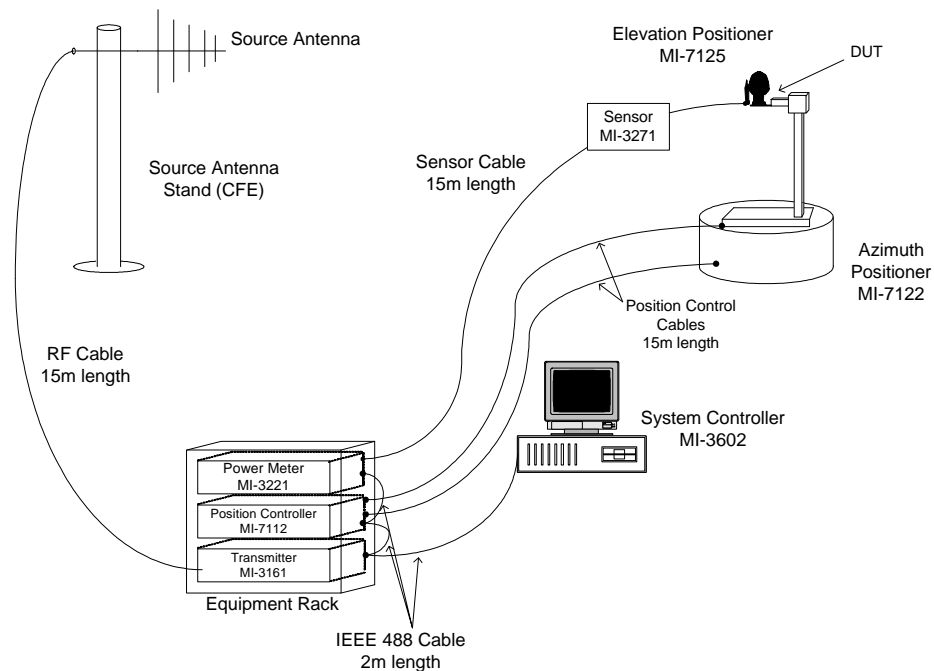

MI-3621 Specifications:

System Workstation:

- MI-3602 workstation includes a computer, monitor, keyboard, mouse, color printer, ethernet card, and IEEE card
- Data acquisition and analysis software provides:
 - ▲ Automatic calculation of beam width, beam peak, location and depth of nulls, location and level of side-lobes, and gain
 - ▲ Polar or rectangular format plots

Signal Source:

- MI-3161 Narrow Band Synthesizer
- Two Bands may be selected from the following: 500 to 800 MHz; 800 to 1,200 MHz; 1,000 to 1,500 MHz; 1,500 to 2,000 MHz; and 2,000 to 2,500 MHz
- Power: 10 dBm max

Receiver:

- MI-3221 Power Meter with sensor
- Input Power: -70 to +30 dBm
(RF filtering of the receiver may be required, depending on your application)

Positioner:

- | | |
|--|--|
| <ul style="list-style-type: none"> ➤ MI-7122 Azimuth Positioner <ul style="list-style-type: none"> ▲ Diameter: 0.8 meter (31.5 inches) ▲ Vertical load handling: 75 kg (165 lbs) ▲ Speed: 0.3 to 3 rpm ▲ Rotation: \pm 200 degrees ▲ Angular accuracy: 0.5 degrees | <ul style="list-style-type: none"> ➤ MI-7125 Elevation Positioner <ul style="list-style-type: none"> ▲ Total height: 1.8 meters (71 inches) ▲ Max. load: 10 kg (22 lbs) ▲ Material: PVC, weatherproof ▲ Positioning accuracy: \pm 1 degree ▲ Rotation angle: 360 degrees ▲ Configuration may vary |
|--|--|

Position Controller:

- MI-7112 provides two axes of control
- IEEE 488 based

Source Antenna:

- Linearly polarized, log periodic

Cables:

- 15-meter cables are provided to support equipment separation

Options:

- Standard gain antennas
- Masts for source antenna and DUT
- Absorber and longer cables
- System shown with optional hollow head
- Contact factory for alternate configurations



**MI-7125 Positioner with
Optional Head**

MI-3622 Far-Field System - Dual-Axis / Spectrum Analyzer

Key Features & Benefits

- Using a narrow band synthesizer to select any two bands within 500 MHz to 2.5 GHz frequency range provide flexibility and wide coverage.
- A spectrum analyzer receiver provides superior RF selectivity.
- Extensive analysis software is built-in to simplify pattern evaluation.
- Network connection provides means to easily download data for offline analysis.

Two Bands within 500 MHz to 2.5 GHz

- Automated dual-axis pattern measurements offer maximum flexibility and control with an advanced yet economical DUT positioner.
- Dielectric elevation positioner produces low perturbations to the measurements.
- Pattern plotting in polar or rectangular format for single or multiple patterns offers the ultimate in flexible data presentation.

Description

The MI-3622 is a mid-range, dual-axis far-field measurement system in the MI-3600 family designed for the Wireless market. Assembled to meet the needs of the most demanding test and measurement environments, the MI-3622 is a complete instrumentation system consisting of a workstation computer and software, dual-axis positioner with combined azimuth and elevation angle control for rotating the Device-Under-Test (DUT), position controller, receiver, transmitter, and broadband linearly polarized log periodic source antenna. The distinguishing elements of the MI-3612 are the spectrum analyzer receiver, narrow band synthesizer transmitter, and dual-axis DUT positioner. The system provides superior ease of use that includes setup, test parameter provisioning, data acquisition, and data analysis. Using the workstation controller, an operator can select the frequency from one of two narrow band synthesized signal sources and record the received signal from the broadband, highly accurate spectrum analyzer receiver. Various options include standard gain antennas for calibration, masts for the source antenna and the DUT positioner, longer signal and control cables and absorber. The acronym CFE refers to Customer Furnished Equipment.

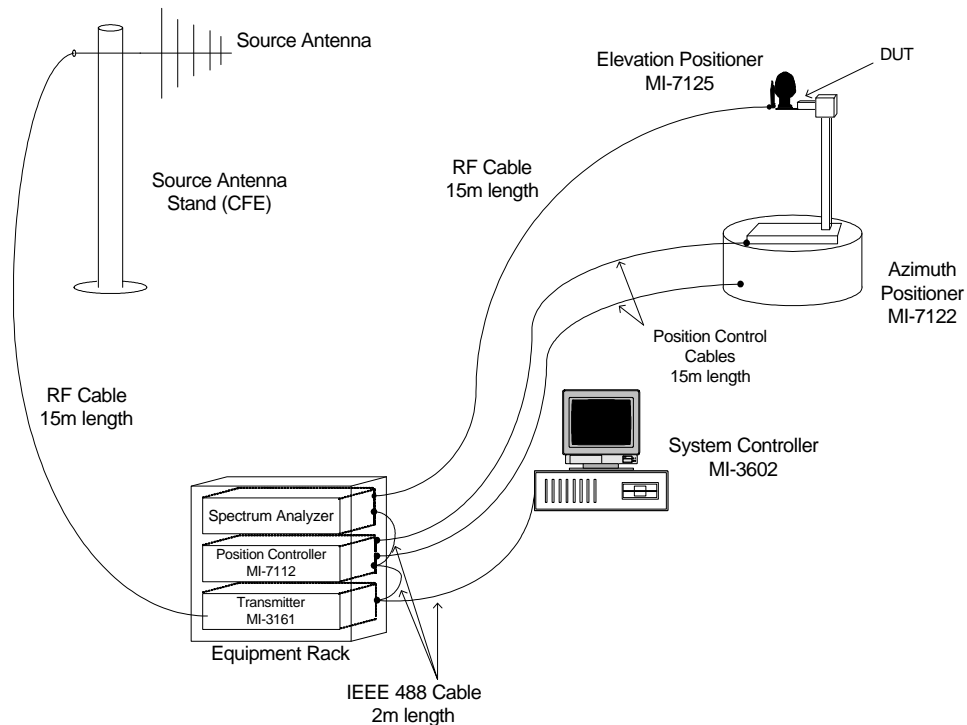

MI-3622 Specifications

System Workstation:

- MI-3602 workstation includes a computer, monitor, keyboard, mouse, color printer, ethernet card, and IEEE card
- Data acquisition and analysis software provides:
 - ▲ Automatic calculation of beam width, beam peak, location and depth of nulls, location and level of side-lobes, and gain
 - ▲ Polar or rectangular format plots

Signal Source:

- MI-3161 Narrow Band Synthesizer
 - ▲ Two bands may be selected from the following: 500 to 800 MHz; 800 to 1,200 MHz; 1,000 to 1,500 MHz; 1,500 to 2,000 MHz; and 2,000 to 2,500 MHz
- Power: 10 dBm max

Receiver:

- Spectrum Analyzer
 - 3 dB resolution bandwidth
 - Dynamic range: 110 dB (narrowband)
 - Input power: -10 dBm max
- (MI Technologies has partnered with the Anritsu Company for the supply of vector network analyzers, spectrum analyzers and other products for use in the MI-3600 family of antenna test and measurement systems)

Positioner:

- | | |
|--|--|
| <ul style="list-style-type: none"> ➤ MI-7122 Azimuth Positioner <ul style="list-style-type: none"> ▲ Diameter: 0.8 meter (31.5 inches) ▲ Vertical load handling: 75 kg (165 lbs) ▲ Speed: 0.3 to 3 rpm ▲ Rotation: ± 200 degrees ▲ Angular accuracy: 0.5 degrees | <ul style="list-style-type: none"> ➤ MI-7125 Elevation Positioner <ul style="list-style-type: none"> ▲ Total height: 1.8 meters (71 inches) ▲ Max. load: 10 kg (22 lbs) ▲ Material: PVC, weatherproof ▲ Positioning accuracy: ± 1 degree ▲ Rotation angle: 360 degrees ▲ Configuration may vary |
|--|--|

Position Controller:

- MI-7112 provides two axes of control
- IEEE 488 based

Source Antenna:

- Linearly polarized, log periodic

Cables:

- 15-meter cables are provided to support equipment separation

Options:

- Standard gain antennas
- Masts for source antenna and DUT
- Absorber and longer cables
- Contact factory for alternate configurations



MI-3623 Far-Field System - Dual-Axis / Vector Network Analyzer

Key Features & Benefits

500 MHz to 3.0 GHz

- Using a vector network analyzer over the 500 MHz to 3.0 GHz frequency band provides increased flexibility and frequency control.
- Automated pattern measurements offer maximum flexibility and control with an advanced yet economical dual-axis DUT positioner.
- Extensive analysis software is built-in to simplify pattern evaluation.
- Network connection provides means to easily download data for offline analysis.
- A vector network analyzer provides superior broadband measurements with high dynamic range and increased frequency resolution.
- Pattern plotting in polar or rectangular format for single or multiple patterns offers the ultimate in flexible data presentation.
- Dielectric elevation positioner produces low perturbations to the measurements.

Description

The MI-3623 is a high-end, dual-axis far-field measurement system in the MI-3600 family designed for the Wireless market. Assembled to meet the needs of the most demanding test and measurement environments, the MI-3623 is a complete instrumentation system consisting of a workstation computer and software, dual-axis positioner with combined azimuth and elevation control for rotating the Device-Under-Test (DUT), position controller, vector network analyzer, and broadband linearly polarized log periodic source antenna. The distinguishing elements of the MI-3623 are the vector network analyzer, which combines a broadband receiver with a broadband transmitter with coverage to 3.0 GHz, and the dual-axis DUT positioner. The system provides superior ease of use that includes setup, test parameter provisioning, data acquisition, and data analysis. Using the workstation controller, an operator can select the transmit frequencies of operation and record the received signal from the broadband, highly accurate vector network analyzer. Various options include standard gain antennas for calibration, masts for the source antenna and the DUT positioner, longer signal and control cables and absorber. The acronym CFE refers to Customer Furnished Equipment.

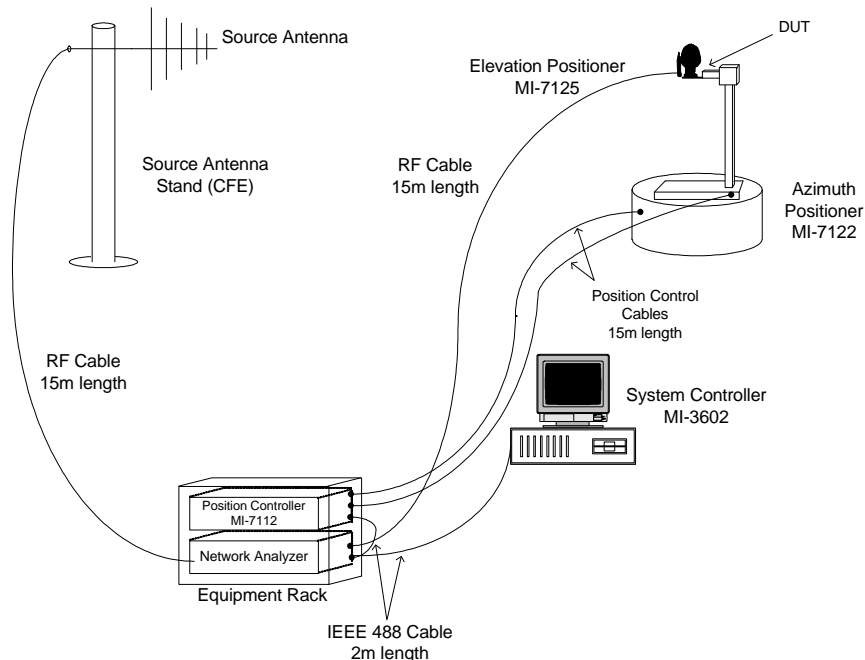

MI-3623 Specifications:

System Workstation:

- MI-3602 workstation includes a computer, monitor, keyboard, mouse, color printer, ethernet card, and IEEE card
- Data acquisition and analysis software provides:
 - ▲ Automatic calculation of beam width, beam peak, location and depth of nulls, location and level of side-lobes, and gain
 - ▲ Polar or rectangular format plots

Receiver and Signal Source:

- Vector network analyzer
- Frequency resolution: 1 Hz
- System dynamic range: 100 dB
- Input impedance: 50 ohms
- Source power: 10 dBm max

(MI Technologies has partnered with the Anritsu Company for the supply of vector network analyzers, spectrum analyzers and other products for use in the MI-3600 family of antenna test and measurement systems)

Positioner:

- | | |
|--|--|
| <ul style="list-style-type: none"> ➤ MI-7122 Azimuth Positioner <ul style="list-style-type: none"> ▲ Diameter: 0.8 meter (31.5 inches) ▲ Vertical load handling: 75 kg (165 lbs) ▲ Speed: 0.3 to 3 rpm ▲ Rotation: ± 200 degrees ▲ Angular accuracy: 0.5 degrees | <ul style="list-style-type: none"> ➤ MI-7125 Elevation Positioner <ul style="list-style-type: none"> ▲ Total height: 1.8 meters (71 inches) ▲ Max. load: 10 kg (22 lbs) ▲ Material: PVC, weatherproof ▲ Positioning accuracy: ± 1 degree ▲ Rotation angle: 360 degrees ▲ Configuration may vary |
|--|--|

Position Controller:

- MI-7112 provides two axes of control
- IEEE 488 based

Source Antenna:

- Linearly polarized, log periodic

Cables:

- 15-meter cables are provided to support equipment separation

Options:

- Standard gain antennas
- Masts for source antenna and DUT
- Absorber and longer cables
- Contact factory for alternate configurations



Vector Network Analyzer

MI-3624 Far-Field System - Dual-Axis / Synthesizer Source

Key Features & Benefits

500 MHz to 2.1 GHz

- Using a synthesized source transmitter within the 500 MHz to 2.1 GHz frequency range provides flexibility and wide coverage.
- A power meter presents the most economical receiver configuration.
- Extensive analysis software is built-in to simplify pattern evaluation.
- Network connection provides means to easily download data for offline analysis.
- Automated pattern measurements offer maximum flexibility and control with an advanced yet economical dual axis DUT positioner.
- Dielectric elevation positioner produces low perturbations to the measurements.
- Pattern plotting in polar or rectangular format for single or multiple patterns offers the ultimate in flexible data presentation.

Description:

The MI-3624 is a mid-range, dual-axis far-field measurement system in the MI-3600 family designed for the Wireless market. Assembled to meet the needs of the most demanding test and measurement environments, the MI-3624 is a complete instrumentation system consisting of a workstation computer and software, dual-axis positioner with combined azimuth and elevation angle control for rotating the Device-Under-Test (DUT), position controller, receiver, transmitter, and broadband linearly polarized log periodic source antenna. The distinguishing elements of the MI-3624 are the power meter receiver, broadband synthesized source transmitter, and dual-axis DUT positioner. The system provides superior ease of use that includes setup, test parameter provisioning, data acquisition, and data analysis. Using the workstation controller, an operator can select the operating frequencies from the synthesized source transmitter and record the received signal from the broadband, highly accurate power meter receiver. Various options include standard gain antennas for calibration, masts for the source antenna and the DUT positioner, longer signal and control cables and absorber. The acronym CFE refers to Customer Furnished Equipment.

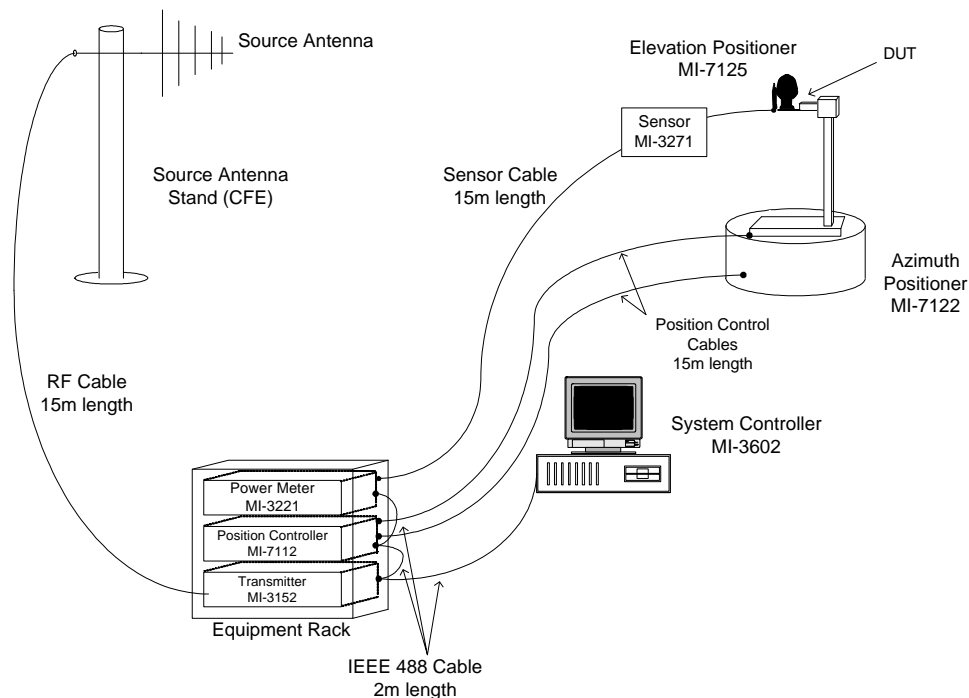

MI-3624 Specifications:

System Workstation:

- MI-3602 workstation includes a computer, monitor, keyboard, mouse, color printer, ethernet card, and IEEE card
- Data acquisition and analysis software provides:
 - ▲ Automatic calculation of beam width, beam peak, location and depth of nulls, location and level of side-lobes, and gain
 - ▲ Polar or rectangular format plots

Signal Source:

- MI-3152 Signal Generator
- Power: 10 dBm max

Receiver:

- MI-3221 Power Meter with Sensor
- Input Power: -70 to +30 dBm
(RF filtering of the receiver may be required, depending on your application)

Positioner:

- | | |
|--|--|
| <ul style="list-style-type: none"> ➤ MI-7122 Azimuth Positioner <ul style="list-style-type: none"> ▲ Diameter: 0.8 meter (31.5 inches) ▲ Vertical load handling: 75 kg (165 lbs) ▲ Speed: 0.3 to 3 rpm ▲ Rotation: ± 200 degrees ▲ Angular accuracy: 0.5 degrees | <ul style="list-style-type: none"> ➤ MI-7125 Elevation Positioner <ul style="list-style-type: none"> ▲ Total height: 1.8 meters (71 inches) ▲ Max. load: 10 kg (22 lbs) ▲ Material: PVC, weatherproof ▲ Positioning accuracy: ± 1 degree ▲ Rotation angle: 360 degrees |
|--|--|

Position Controller:

- MI-7112 provides two axes of control
- IEEE 488 based

Source Antenna:

- Linearly polarized, log periodic

Cables:

- 15-meter cables are provided to support equipment separation

Options:

- Standard gain antennas
- Masts for source antenna and DUT
- Absorber and longer cables
- Contact factory for alternate configurations



MI-3152 Signal Generator

MI-3625 Far-Field System - Dual-Axis / Vector Network Analyzer

Key Features & Benefits

500 MHz to 6.0 GHz

- Using a vector network analyzer over the extended frequency range of 500 MHz to 6.0 GHz band provides increased flexibility and frequency control.
- Automated pattern measurements offer maximum flexibility and control with an advanced yet economical dual-axis DUT positioner.
- A vector network analyzer provides superior broadband measurements with high dynamic range and increased frequency resolution.
- Extensive analysis software is built-in to simplify pattern evaluation.
- Pattern plotting in polar or rectangular format for single or multiple patterns offers the ultimate in flexible data presentation.
- An Ethernet connection provides a means to easily download data for offline analysis.
- Dielectric elevation positioner produces low perturbations to the measurements.

Description:

The MI-3625 is a high-end, dual-axis far-field measurement system in the MI-3600 family designed for the Wireless market. Assembled to meet the needs of the most demanding test and measurement environments, the MI-3625 is a complete instrumentation system, consisting of a workstation computer and software, dual-axis positioner with combined azimuth and elevation angle control for rotating the Device-Under-Test (DUT), position controller, network analyzer, and broadband linearly polarized log periodic source antenna. The distinguishing elements of the MI-3625 are the vector network analyzer, which combines a broadband receiver with a broadband transmitter with coverage to 6.0 GHz, and dual-axis DUT positioner. The system provides superior ease of use that includes setup, test parameter provisioning, data acquisition, and data analysis. Using the workstation controller, an operator can select the transmit frequencies of operation and record the received signal from the broadband, highly accurate vector network analyzer. Various options include standard gain antennas for calibration, masts for the source antenna and the DUT positioner, longer signal and control cables and absorber. The acronym CFE in the illustration below refers to Customer Furnished Equipment.

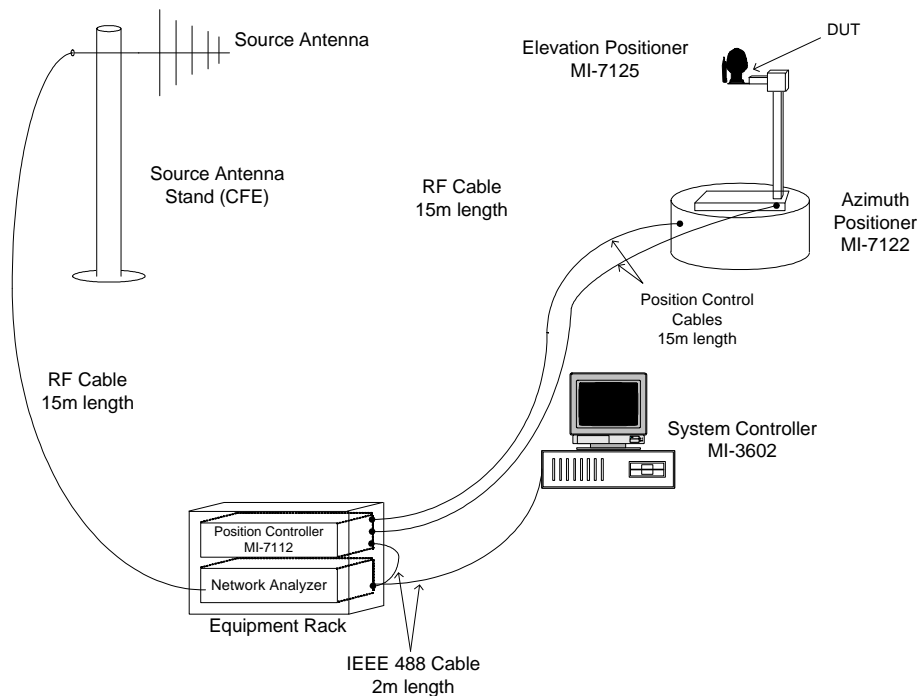

MI-3625 Specifications:

System Workstation:

- MI-3602 workstation includes a computer, monitor, keyboard, mouse, color printer, ethernet card, and IEEE card
- Data acquisition and analysis software provides:
 - ▲ Automatic calculation of beam width, beam peak, location and depth of nulls, location and level of side-lobes, and gain
 - ▲ Polar or rectangular format plots

Receiver and Signal Source:

- Vector network analyzer
 - Dynamic range: 100 dB
 - Input impedance: 50 ohms
 - Source power: 5 dBm max
- (MI Technologies has partnered with the Anritsu Company for the supply of vector network analyzers, spectrum analyzers and other products for use in the MI-3600 family of antenna test and measurement systems)

Positioner:

- | | |
|--|--|
| <ul style="list-style-type: none"> ➤ MI-7122 Azimuth Positioner <ul style="list-style-type: none"> ▲ Diameter: 0.8 meter (31.5 inches) ▲ Vertical load handling: 75 kg (165 lbs) ▲ Speed: 0.3 to 3 rpm ▲ Rotation: ± 200 degrees ▲ Angular accuracy: 0.5 degrees | <ul style="list-style-type: none"> ➤ MI-7125 Elevation Positioner <ul style="list-style-type: none"> ▲ Total height: 1.8 meters (71 inches) ▲ Max. load: 10 kg (22 lbs) ▲ Material: PVC, weatherproof ▲ Positioning accuracy: ± 1 degree ▲ Rotation angle: 360 degrees ▲ Configuration may vary |
|--|--|

Position Controller:

- MI-7112 provides two axes of control
- IEEE 488 based

Source Antenna:

- Linearly polarized, log periodic

Cables:

- 15-meter cables are provided to support equipment separation

Options:

- Standard gain antennas
- Masts for source antenna and DUT
- Absorber and longer cables
- Contact factory for alternate configurations

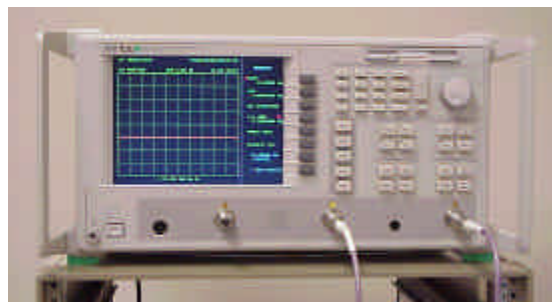

Vector Network Analyzer

MI-3630 Planar Near-field Antenna Measurement System

Key Features & Benefits

- Rapid, accurate planar near-field measurements support near-field diagnostics and fast transformation to the far field for antenna pattern evaluation.
- Planar surface scanner geometry is ideally suited for measuring planar arrays or reflectors with medium to high gain and single or multiple beams commonly found in Wireless smart base station antennas, point to point and point to multipoint antennas, repeater relay antennas, and satellite antennas.
- Broad frequency coverage over 400 MHz to 18 GHz band handles most common measurement requirements.
- Models available with a variety of planar scanner probe travel areas to suit specific test requirements for a broad array of applications.
- Easy-to-use software provides data collection, processing and display.
- Data output includes patterns, contours, and 3-D plots of amplitude and phase offering the most discriminating analyst access to useful data presentations.
- Hardware is lightweight, compact, and portable, making it simple to install and convenient to use.
- Compatibility with high quality RF test equipment assures accurate measurements.
- Pattern output in contour, 3-D, polar or rectangular formats offers flexible data plotting.
- Network connection provides means to easily download data for offline analysis.

Description

The MI-3630 family of planar near-field measurement systems is designed for test and measurement applications in the Wireless industry. The systems provide fast, accurate near-field diagnostics and transformation to the far field for antenna pattern evaluation. The planar surface scanner geometry is ideally suited for measuring planar arrays or reflectors with medium to high gain and single or multiple beams commonly found in wireless, point-to-point and point-to-multipoint antennas and repeater relay antennas. The MI-3630 system consists of a precision planar (X-Y axes) scanner, a near-field probe, dual-axis position controller and a workstation computer and software. The MI-3630 is easy to use, with software prompts to help operators complete setup and establish test parameter provisioning, data acquisition and data analysis. Using the system's workstation, an operator can quickly set the measurement frequency, configure the scanner, initiate a scan, and collect, process and display test data. The MI-3630 is compatible with a number of commercially available network analyzers. Various options are offered that extend utility of the MI-3630 systems. The options are listed on the following page.



MI-3630 system shown with optional computer desk and vector network analyzer.

Note: actual configuration may vary.

MI-3630 Specifications:

Probe:

- WR-430 (1.70-2.60 GHz) open ended waveguide with SMA transition (other probes optional)

Absorber:

- Scanner: 12 inch pyramidal absorber
- Probe: 12 inch pyramidal absorber

Probe Mount:

- Bracket permitting vertical and horizontal mounting of probe

Model *	Measurement Area (Horizontal by Vertical)
MI-3630-3x3	3 ft x 3 ft
MI-3630-6x6	6 ft x 6 ft
MI-3630-8x8	8 ft x 8 ft
MI-3630-10X10	10 ft x 10 ft

RF Cables:

- Flexible 10 ft length (3 m) with SMA (M-M) coaxial connectors, DC to 18 GHz (4 each)

RF Devices Supported:

- MI-1783, MI-1795, MI-1797, Anritsu MS4623B, Agilent 8510A/B/C, Agilent 8530A, Agilent 8753A/B/C/D/E/ES, (Contact factory for complete list.)

Operating Frequency:

- 400 MHz to 18 GHz depending upon choice of customer furnished MI receiver or vector network analyzer

Workstation and Software:

- MI-3603P computer with monitor, color printer, keyboard, and mouse, MI-3603P system control, acquisition software, and planar near-field software

Power:

- 115/250 VAC, 50/60 Hz, 10 A, Single Phase

Planarity:

- 0.010 inches RMS

Repeatability:

- 0.002 inches

Options:

- Standard gain antennas for calibration
- Motorized probe polarization rotation
- Motorized probe Z-axis control
- Probes for other frequencies
- MI receiver and vector network analyzer
- Sources
- Chamber
- DUT positioner and mast

*Other sizes and configurations available



MI-3640 Cylindrical Near-field Antenna Measurement System

Key Features & Benefits

- Rapid, accurate cylindrical near-field measurements support near-field diagnostics and fast transformation to the far field for antenna pattern evaluation.
- Cylindrical surface scanner geometry is ideally suited for measuring omnidirectional and fan-beams of linear and panel arrays commonly used for Wireless base station antennas.
- Broad frequency coverage over 400 MHz to 18 GHz band handles most common measurement requirements.
- High quality RF test equipment assures accurate measurements.
- Easy-to-use software provides data collection, processing and display.
- Models available with a variety of cylindrical scanner probe travel lengths to suit specific test requirements for a broad array of applications.
- Data output includes patterns, contours, and 3-D plots of amplitude and phase offering the most discriminating analyst access to useful data presentations.
- Hardware is lightweight, compact, and portable making it simple to install and convenient to use.
- Pattern output in contour, 3-D, polar or rectangular formats offers flexible data plotting.
- Network connection provides means to easily download data for offline analysis.

Description

The MI-3640 family of cylindrical near-field measurement systems is designed for test and measurement applications in the Wireless industry. The systems provide fast, accurate near-field diagnostics and transformation to the far field for antenna pattern evaluation. The cylindrical scanner configuration is ideally suited for measuring antennas commonly found in wireless, base station applications. The MI-3640 system consists of a precision vertical scanner, azimuth positioner for device under test (DUT), near-field probe, dual-axis position controller and a workstation computer and software. The MI-3640 is easy to use, with software prompts to help operators complete setup and establish test parameter provisioning, data acquisition and data analysis. Using the system's workstation, an operator can quickly set the measurement frequency, configure the scanner, initiate a scan, and collect, process and display test data. The MI-3640 is compatible with a number of commercially available vector network analyzers. Various options are offered that extend utility of the MI-3640 systems. The options are listed on the following page.

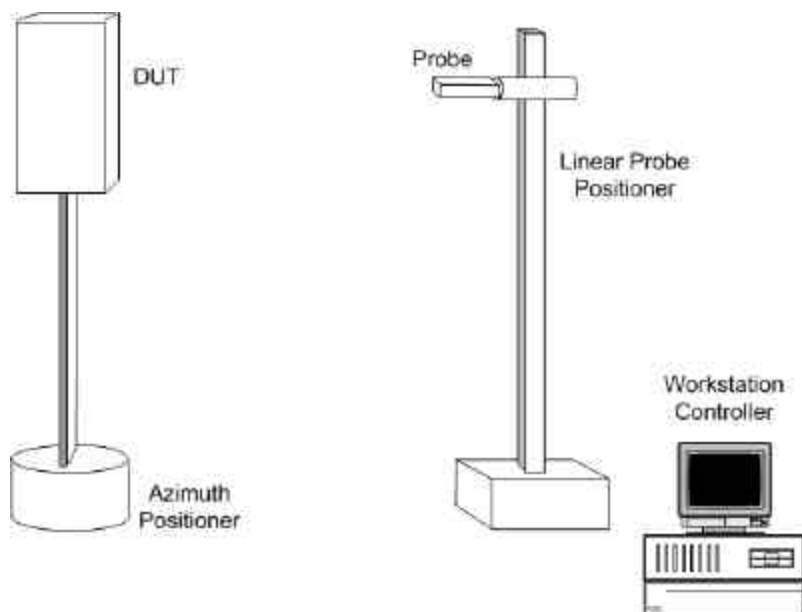

MI-3640 Specifications:

Azimuth Rotation:

- 360 degrees

Maximum Azimuth Positioner Vertical Load:

- 1000 lbs

Probe:

- WR-430 (1.70 to 2.60 GHz) open ended waveguide with SMA transition (other probes optional)

Model	Vertical Scan Length*
MI-3640-6	6 ft
MI-3640-8	8 ft
MI-3640-10	10 ft

Absorber:

- Scanner: 12 inch pyramidal absorber
- Probe: 12 inch pyramidal absorber

Probe Mount:

- Bracket permitting vertical and horizontal mounting of probe

RF Cables:

- Flexible 10 ft length (3 m) with SMA (M-M) coaxial connectors, DC to 18 GHz (4 each)

Rotary Joint:

- DC to 18 GHz for Azimuth Positioner

RF Devices Supported:

- MI-1783, MI-1795, MI-1797, Anritsu MS4623B, Agilent 8510A/B/C, Agilent 8530A, Agilent 8753A/B/C/D/E/ES, (Contact factory for complete list.)

Operating Frequency:

- 400 MHz to 18 GHz depending upon choice of customer furnished MI receiver or vector network analyzer

Workstation and Software:

- MI-3603C computer with monitor, color printer, keyboard, and mouse, MI-3603C system control, acquisition software, and cylindrical near-field software

Power:

- 115/250 VAC, 50/60 Hz, 10 A, Single Phase

Angular Accuracy:

- 0.01 degrees

Linearity (Probe axis to DUT rotation axis):

- 0.010 inches RMS

Repeatability:

- 0.002 inches

Options:

- Standard gain antennas for calibration
- Motorized probe polarization rotation
- Motorized probe Z-axis control
- Probes for other frequencies
- MI receiver and vector network analyzer
- Sources
- Chamber



MI-3650 Spherical Near-field Antenna Measurement System

Key Features & Benefits

- Rapid, accurate spherical near-field measurements support near-field diagnostics and fast transformation to the far field for antenna pattern evaluation.
- The spherical surface scanner geometry is ideally suited for measuring broad beam patterns with medium to low gain, characteristic of single elements, electrically small antennas, and embedded elements such as antennas commonly found in a wide variety of personal Wireless devices that include mobile phones, PDAs, pocket PCs, Laptops, GPS receivers, and automotive Wireless electronics.
- Broad frequency coverage over 400 MHz to 18 GHz band covers most common measurement requirements.
- Models available with a variety of measurement sphere diameters to suit specific test requirements for a broad array of applications.
- Easy-to-use software provides data collection, processing, and display.
- Data output includes patterns, contours, and 3-D plots of amplitude and phase offering the most discriminating analyst access to a useful data presentation.
- Hardware is lightweight, compact, and portable, making it simple to install and convenient to use.
- High quality RF test equipment assures accurate measurements.
- Pattern output in polar or rectangular formats for single or multiple patterns offers the ultimate in flexible data plotting.
- Network connection provides means to easily download data for offline analysis.

Key Features & Benefits

The MI-3650 family of spherical near-field measurement systems is designed for test and measurement applications in the Wireless industry. The systems provide fast, accurate near-field diagnostics and transformation to the far field for antenna pattern evaluation. The spherical scanner configuration is ideally suited for measuring antennas commonly found in mobile wireless applications such as handsets. The MI-3650 system consists of a dual axis phi-over-theta positioner for the device under test (DUT), near-field probe, dual-axis position controller and a workstation computer and software. The MI-3650 is easy to use, with software prompts to help operators complete setup and establish test parameter provisioning, data acquisition and data analysis. Using the system's workstation, an operator can quickly set the measurement frequency, configure the scanner, initiate a scan, and collect, process and display test data. The MI-3650 is compatible with a number of commercially available network analyzers. Various options are offered that extend utility of the MI-3650 systems. The options are listed on the following page.

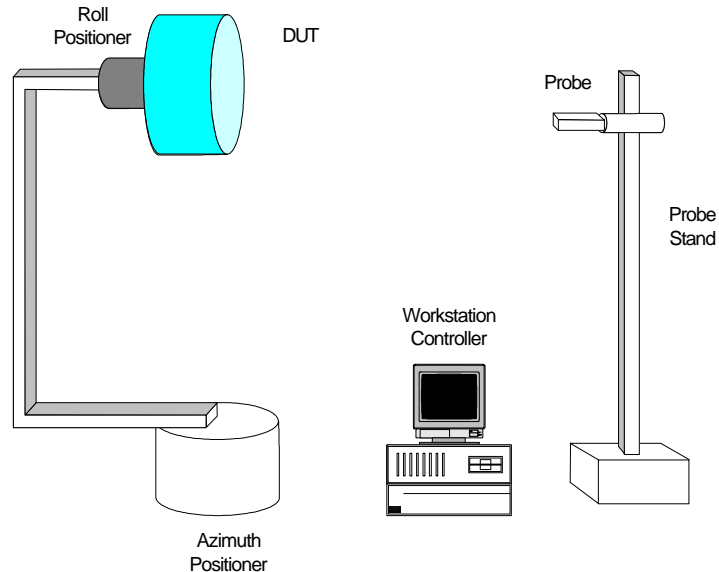

MI-3650 Specifications:

Antenna Load:

- 40 lbs max

Probe:

- WR-430 (1.70 to 2.60 GHz) spherical near-field probe with SMA transition (other probes optional)

Model	Measurement Sphere Diameter
MI-3650-3	3 ft
MI-3650-6	6 ft
MI-3650-9	9 ft

Absorber:

- Scanner: 8 inch pyramidal absorber
- Probe: 8 inch pyramidal absorber

RF Cables:

- Flexible 10 ft length (3 m) with SMA (M-M) coaxial connectors, DC to 18 GHz (4 each)

Rotary Joint:

- DC to 18 GHz, three of each for phi, theta and polarization

RF Devices Supported:

- MI-1783, MI-1795, MI-1797, Anritsu MS4623B, Agilent 8510A/B/C, Agilent 8530A, Agilent 8753A/B/C/D/E/ES, (Contact factory for complete list.)

Operating Frequency:

- 400 MHz to 18 GHz depending upon choice of customer furnished MI receiver or vector network analyzer

Workstation and Software:

- MI-3603S computer with monitor, color printer, keyboard, and mouse, MI-3603S system control, acquisition software, and spherical near-field software

Power:

- 115/250 VAC, 50/60 Hz, 10 A, Single Phase

Angular Accuracy:

- 0.01 degrees

Repeatability:

- 0.002 degrees

Options:

- Standard gain antennas for calibration
- Motorized probe polarization rotation
- Motorized probe Z-axis control
- Probes for other frequencies
- MI receiver and vector network analyzer
- Sources
- Chamber



MI-3600 Cost-Effective Range Measurement Workstation Products

The MI-3600 Family of Workstation Products offers an affordable solution to perform measurements for the organization that already owns all or part of the necessary and supported range hardware for specific tests.

MI Technologies recognizes the economic pressures placed on capital expenditure budgets particularly for companies in the commercial Wireless markets. The MI-3600 Family of Workstation Products address a computer-software need for the company that does not require an entire range measurement system. These workstations may be purchased alone or with select hardware components for a particular measurement configuration.

The MI-3600 Family of Workstation Products includes different models that perform either far-field or near-field range measurements. Each model is a complete package consisting of all necessary software and a measurement workstation. The suite of software includes advanced modules for equipment provisioning, data acquisition, calibration, analysis, and appropriate hardware drivers. The workstation is complete with a personal computer (400 MHz or faster CPU), monitor, keyboard, mouse, color printer and data acquisition hardware. The software is pre-installed on the workstation at the factory.

The MI-3600 Software Product Family includes the following models:

- Far-Field Range Measurements
 - ▲ MI-3601 Single-Axis Data Acquisition & Analysis
 - ▲ MI-3602 Dual-Axis Data Acquisition & Analysis
- Near-Field Range Measurements
 - ▲ MI-3603P Planar Near-Field Data Acquisition & Analysis
 - ▲ MI-3603C Cylindrical Near-Field Data Acquisition & Analysis
 - ▲ MI-3603S Spherical Near-Field Data Acquisition & Analysis

MI-3601 and MI-3602 Range Measurement Workstation Packages

The MI-3601 and MI-3602 workstation packages provide acquisition and analysis capability for far-field antenna measurements. The MI-3601 supports single-axis far-field measurement systems and the MI-3602 supports dual-axis far-field measurement systems when using supported positioners and RF instrumentation.

Both the MI-3601 and the MI-3602 acquisition and analysis software products provide the following functions and features:

- Data acquisition and storage
- Data analysis of common antenna pattern parameters
- Measurement feedback through real-time confirmation plotting
- Multi-data trace display
- Gain calibration
- Advanced measurement scripting



MI-3603P Planar Near-Field Measurement Workstation Package

The MI-3603P workstation supports the planar near-field scanners in the MI-3600 family, including the MI-3630-3x3, MI-3630-6x6, MI-3630-8x8 and the MI-3630-10x10. The software provides the following functions and features for supported positioning equipment and RF instrumentation:

- Data acquisition over a planar surface in front of the device under test
- Measurement feedback through real-time confirmation plotting
- Multi-data trace display
- Gain calibration
- Data analysis of common antenna pattern parameters
 - ▲ Near-field amplitude and phase plots
 - ▲ System error correction associated with thermal drift, planarity, receiver linearity and system losses
 - ▲ Transformation of the corrected near-field data to the far field using MI-developed algorithms
 - ▲ Resultant far-field patterns presented in a variety of coordinate systems and polarizations

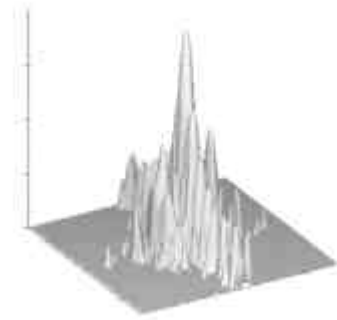

MI-3603C Cylindrical Near-Field Range Measurements Workstation Package

The MI-3603C workstation supports the series of cylindrical near-field measurement systems in the MI-3600 family, including the MI-3640-6 and MI-3640-8 and the MI-3640-10. The software provides the following functions and features for supported positioning equipment and RF instrumentation:

- Data acquisition over a cylindrical surface enclosing the DUT
- Measurement feedback through real-time confirmation plotting
- Multi-data trace display
- Gain calibration
- Data analysis of common antenna pattern parameters
 - ▲ Near-field amplitude and phase plots
 - ▲ System error correction associated with thermal drift, planarity, receiver linearity and system losses
 - ▲ Transformation of the corrected near-field data to the far field using MI-developed algorithms
 - ▲ Resultant far-field patterns presented in a variety of coordinate systems and polarizations

MI-3603S Spherical Near-Field Range Measurement Workstation Package

The MI-3603S workstation supports the series of spherical near-field measurement systems in the MI-3600 family including the MI-3650-3, MI-3650-6 and the MI-3650-9. The software provides the following functions and features for supported positioning equipment and RF instrumentation:

- Data acquisition over a spherical surface enclosing the DUT
- Measurement feedback through real-time confirmation plotting
- Multi-data trace display
- Gain calibration
- Data analysis of common antenna pattern parameters
 - ▲ Near-field amplitude and phase plots
 - ▲ System error correction associated with thermal drift, planarity, receiver linearity and system losses
 - ▲ Transformation of the corrected near-field data to the far field using TICRA-developed algorithms
 - ▲ Field pattern computation at points equidistantly spaced in theta and phi spherical coordinates in the far field or at any other radius about the DUT
 - ▲ Resultant far-field patterns presented in a variety of coordinate systems and polarizations



Customer Support

MI Technologies understands that test and measurement is vital to your work. It is part of your competitive edge. We define Customer Support in the broadest sense of the word, not merely “service after the sale.” Customer Support at MI Technologies has a clearly defined life cycle that begins when our sales professionals make initial contact with potential customers and continues through our response to an RFQ, our system design, manufacturing, installation at the customer site and our support of that product in the field for its natural life.

We dedicate to you a wide selection of relevant services, a global presence to meet your local needs, and the finest engineers and technicians in the business.

An Unmatched Portfolio of Services for the Entire Measurement Range Lifecycle

MI Technologies ensures your success through a broad portfolio of post warranty programs and professional services that go above and beyond maintenance and repair. We combine extensive consulting services and state-of-the-art technical expertise for every stage of your measurement requirement. Each service is designed to support your needs at specific points along the product lifecycle. Some services transcend the lifecycle providing benefits in more than one phase.

Lifecycle services from MI Technologies are integrated and flexible. You can choose the level of service that matches your needs, even tailor them as required. Providing the best performance for the lowest total cost of ownership over the measurement lifecycle is what MI Technologies’ Customer Support is all about. Our services cover all the bases: consultation, testing, design, training, installation, scheduled maintenance, repairs, spares, operations management, diagnostics, relocations, and refurbishments. We work together with, or in place of, your test range and measurement organization to achieve an optimal balance of performance and cost.

MI Technologies’ Customer Support is the Range Lifecycle Services Leader.



Notes

Notes

MI Technologies Customer Support

MI Technologies' Customer Support unit offers world-class service for our global customer base. From on-site warranty service to range moves, product training to full-service testing at our Range facilities, MI Technologies offers the most comprehensive, responsive and flexible customer support program in the industry. In addition, MI Technologies offers top-of-the-line RF and microwave testing services at our Atlanta-area test facilities, which include a large anechoic chamber, compact range and near-field scanners.



Call us for:

- ◇ Calibrations
- ◇ Range Relocations
- ◇ Range Probe Service
- ◇ Range Operation Services
- ◇ Precision Mechanical Alignment
- ◇ Software Maintenance Contracts
- ◇ Operation and Maintenance Training
- ◇ MI Technologies' Range Test Services
- ◇ Repair and Maintenance Contracts
- ◇ Equipment Refurbishment and Upgrades
- ◇ Warranty Repairs



Test With Confidence



MI Technologies—The Leader in RF and Microwave Control, Test and Measurement



MI Technologies
1-800-854-3660 ■

MI Technologies ■

1125 Satellite Boulevard, Suite 100
Suwanee, Georgia 30024-4629
Tel: 800-854-3660
Tel: 678-475-8300
Fax: 678-542-2601

Website: www.MI-Technologies.com
E-mail: sales@MI-Technologies.com