

A NEW GENERATION PROGRAMMABLE PHASE/AMPLITUDE MEASUREMENT RECEIVER

by

Charles H. Currie

Scientific-Atlanta, Inc.
3845 Pleasantdale Road
Atlanta, Georgia 30340

GENERAL

A new generation programmable, phase-amplitude measurement receiver has been developed which advances the state-of-the-art of antenna pattern measurements. The new receiver features microprocessor-based control and data processing systems resulting in improved performance and versatility.

THE BASIC PHASE-LOCKED RF/IF CONVERSION SYSTEM

A block diagram of the phase-locked RF/IF conversion system used in Scientific-Atlanta phase/amplitude measurement receivers is shown by Figure 1. The system permits phase-locking of the receiver to a sample of a received signal supplied to the RF input of the APC CH mixer. When phase-locked, RF signals supplied to the inputs of the APC CH mixer and the SIG CH mixer are converted to coherent low-frequency IF outputs.

The IF phase-lock loop causes two crystal-stabilized oscillators (frequencies = 45.000 MHz and 45.005 MHz) to be sampled, mixed and then phase-locked to maintain a constant difference frequency (5020 Hz in Figure 1). This difference frequency is determined by the 5020 Hz phase-lock reference supplied to the IF phase detector. An output of the 45.000 MHz oscillator is supplied as the phase-lock reference to the RF phase-lock system. Buffered outputs of the 45.005 MHz oscillator are coupled as local oscillator inputs to the automatic phase control channel (APC CH) and the signal channel (SIG CH) second mixers.

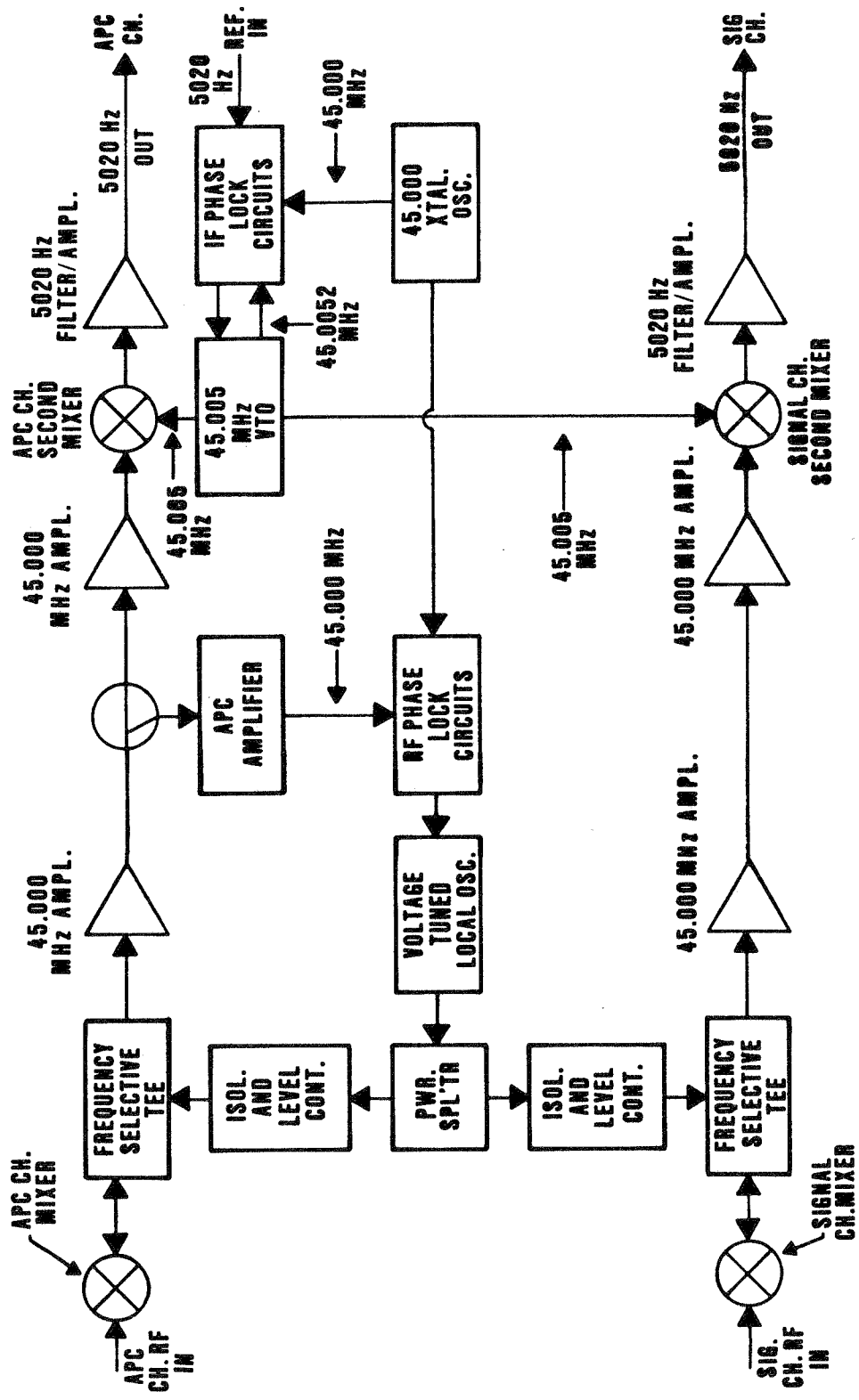

Figure 1. Phase-Locked RF/IF Conversion System Used In The Series 1780 Programmable Receivers

When the voltage-tuned local oscillator output is phase-locked to the received signal frequency, the signals supplied to the APC CH mixer and SIG CH mixer are each converted to 45.000 MHz intermediate frequencies. Since the 45.000 MHz oscillator output serves as the reference for the RF phase-lock loop, the 45.000 MHz SIG CH and APC CH IF signals are coherent with both the 45.000 MHz and 45.005 MHz signals generated in the IF phase lock loop. This relationship results in the 45.000 MHz APC CH and SIG CH signals supplied to the associated second mixers being converted to coherent 5020 Hz signals.

DESIRABLE RECEIVER CHARACTERISTICS

A receiver designed to perform as a general purpose phase/amplitude measurement receiver having features required for general antenna pattern range data measurement should have the following:

- ... wide frequency range.
- ... good sensitivity.
- ... adequate dynamic range.
- ... capability of mixer remoting and separation.
- ... two-channel or three-channel capability.
- ... automatic control capability.
- ... high data-rate capability.
- ... frequency agility.
- ... digital/analog data output capability.
- ... accurate phase/amplitude data readout.
- ... good long term stability.
- ... high interchannel isolation.

THE SERIES 1780 PROGRAMMABLE MICROWAVE RECEIVER

A photograph of the Series 1780 Programmable Microwave Receiver is shown by Figure 2. The assembly consists of four rack mounting subunits, each of which are 5¼ inches high. All receiver controls and displays are mounted on the front panel

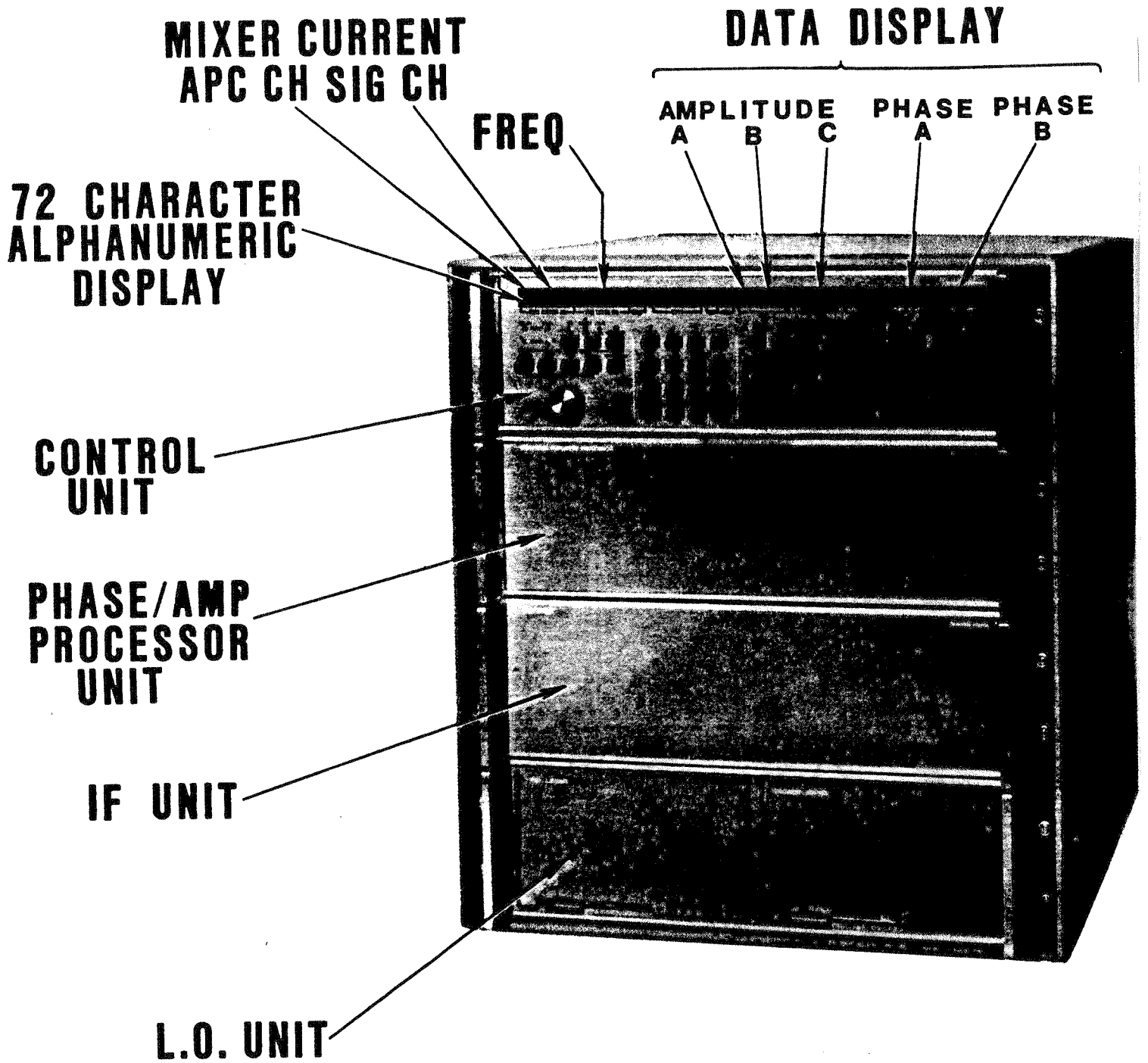

**Figure 2.
MODEL 1783
PROGRAMMABLE
MICROWAVE RECEIVER**

of top unit, which is the microprocessor-based control unit. This panel includes a 72 character alphanumeric display, a keypad, control buttons and LED indicators.

A block diagram of a Model 1783 three-channel receiver is shown in Figure 3. The IEEE-488 standard-bus-compatible control unit interfaces with other receiver units to supply power and control. When the receiver is phase-locked to a signal supplied to the APC CH RF input, the signals supplied to the APC CH and SIG CH RF inputs are converted to coherent 5020-Hz outputs. These 5020-Hz outputs are coupled to the phase-amplitude processor for A/D conversion and processing.

An RF switch operating at a 27.5 kHz rate and synchronized with an IF switch located in the IF unit directs the CH A and CH B RF inputs to the CH A and CH B IF channels respectively. This arrangement provides three input/output channels using two mixers and offers improved phase measurement stability when phase is measured between SIG CH A and SIG CH B. Since the signal-channel mixers and associated receiver-to-mixer cable are common to channels A and B, phase errors due to mechanical or thermal effects in the mixer or cable will cancel.

The microprocessor-based phase/amplitude processor processes the 5020-Hz IF inputs. The processing consists of predetection filtering, post-detection filtering, phase measurements, amplitude function generation (linear, logarithmic or direct ratios), amplitude measurements and output-data formatting. All operations are carried out for three-amplitude channels and two phase channels. The phase/amplitude processor furnishes both a digital (byte-serial) output and an analog output for recording. The recorder output can be programmed to record either any single amplitude channel, any single phase channel or to be OFF.

A total of thirty-two front-panel-programmable service-mode routines are provided in the receiver to facilitate alignment and maintenance. The service modes permit the receiver keyboard and display to be used in an alternate mode of operation. In this mode normal receiver operations are suspended and stored procedures may be used to (1) enter auxiliary frequency band information, (2) enter preset mixer currents and receiver options, (3) to exercise tests and programs that confirm system operation, and (4) assist in general troubleshooting.

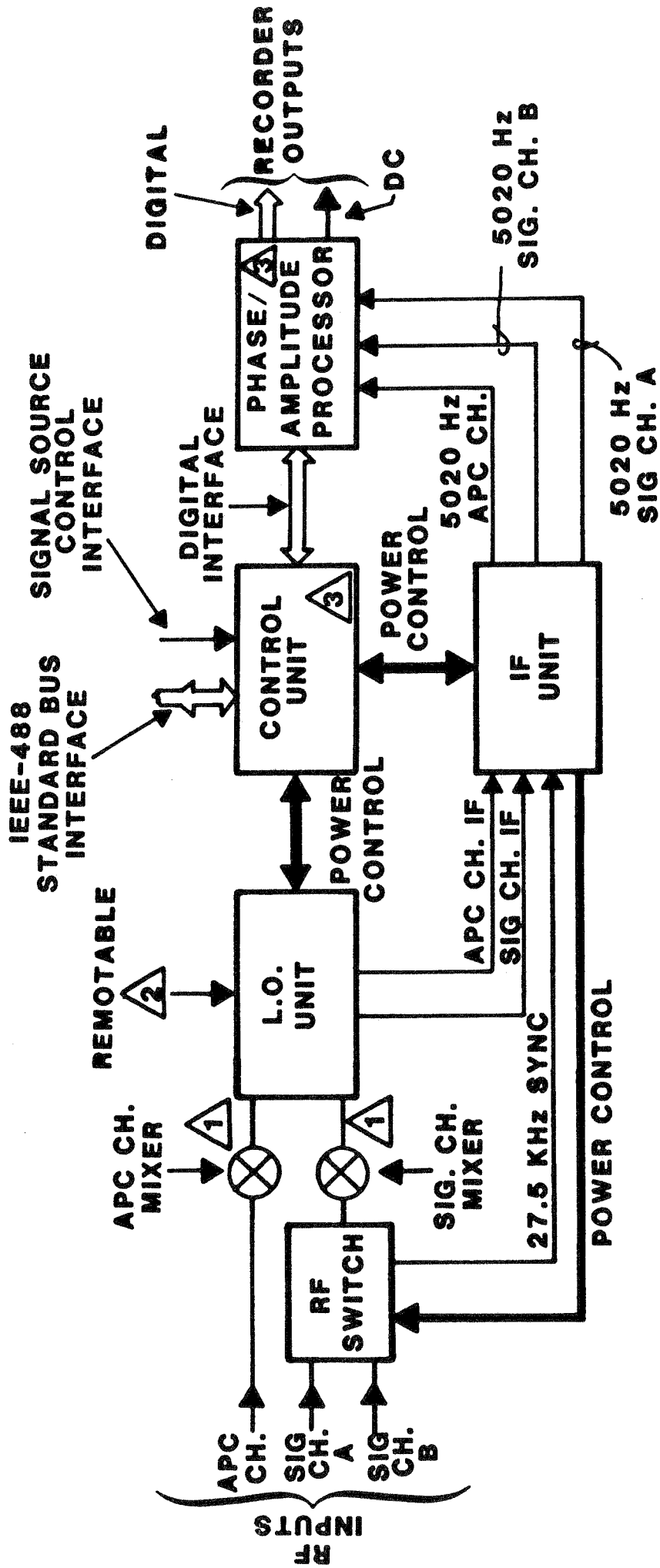

NOTES: 1 CABLE LOSS \leq 3.0db AT 2.045 GHz

2 REMOVABLE UP TO 150' FROM IF UNIT. (THE 150' LENGTH INCLUDES CABLE FROM L.O. UNIT TO APC CH. MIXER)

3 THESE UNITS ARE MICROPROCESSOR BASED

Figure 3. BLOCK DIAGRAM OF MODEL 1783 PROGRAMMABLE MICROWAVE RECEIVER

RECEIVER OPERATING MODES

The Series 1780 receivers have four programmable operating modes (see Figures 4 and 5). The RF/IF signal paths for operating in the DUAL 1 mode are shown by Figure 4A. In this configuration, the SIG CH A RF and the APC CH RF are converted to IF in the appropriate channels.

The RF/IF signal paths when operating in the DUAL 2 mode are shown by Figure 4B. The signal paths are identical to those of the DUAL 1 mode except the RF switch is switched to select the SIG CH B RF input. The DUAL 1/DUAL 2 modes provide the user with a means of using the external RF switch as a programmable coaxial relay.

The SHARED AB mode signal paths are shown by Figure 5B. When operating in this mode, the RF SIG CH A and the RF SIG CH B inputs are synchronously switched at 27.5 kHz such that the signal channel passes both the CH A IF and CH B IF signals simultaneously. This configuration has three RF inputs and three RF outputs.

The DUAL 1 mode (Figure 4A) and the SHARED B mode (Figure 5C) SIG CH RF/IF paths are identical to the two switched RF/IF signal paths of the SHARED AB mode. Static evaluation of either of the two SHARED AB RF/IF signal paths can be accomplished by operating either in the DUAL 1 or the SHARED B mode.

AUTOMATIC CONTROL

All programmable functions of the receiver are controllable through the IEEE-488 standard bus (see Figure 6). During operation the receiver is able to both talk and listen and can be operated with other compatible instruments.

Programmable receiver functions are as follow:

- Automatic/Manual
- IF Mode
- IF Attenuation (CH A, CH B, CH C)
- Mixer Current (APC CH and SIG CH)
- Frequency

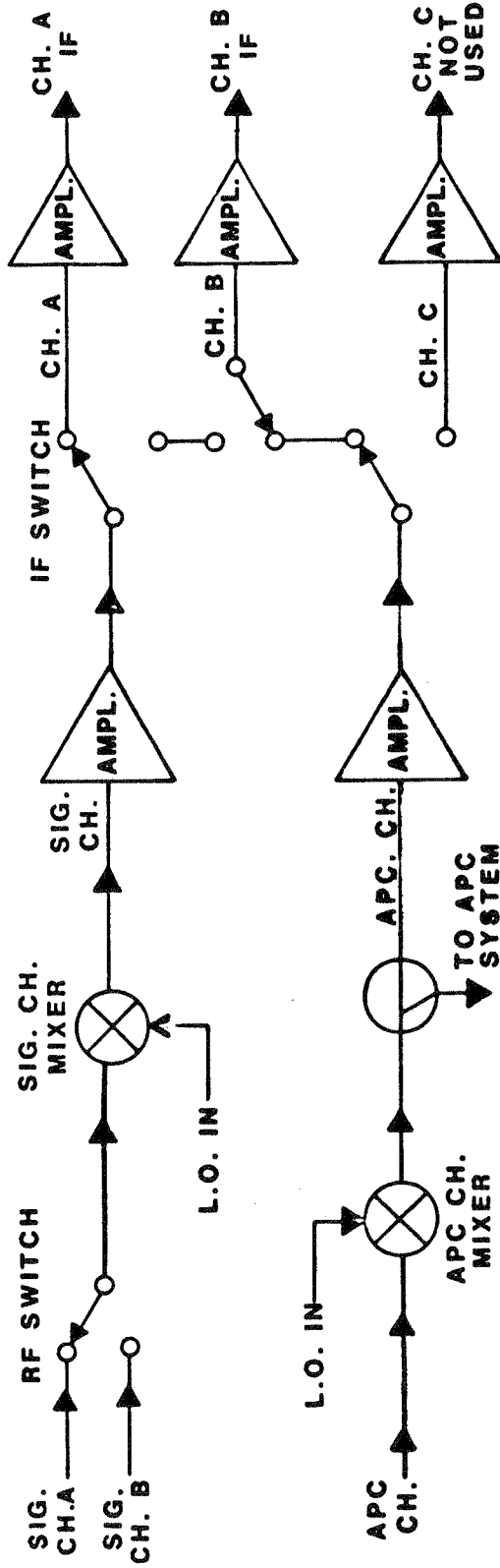

Figure 4A.

DUAL 1 D1(D1) MODE RF/IF CONNECTIONS, TWO OUTPUT CHANNELS.

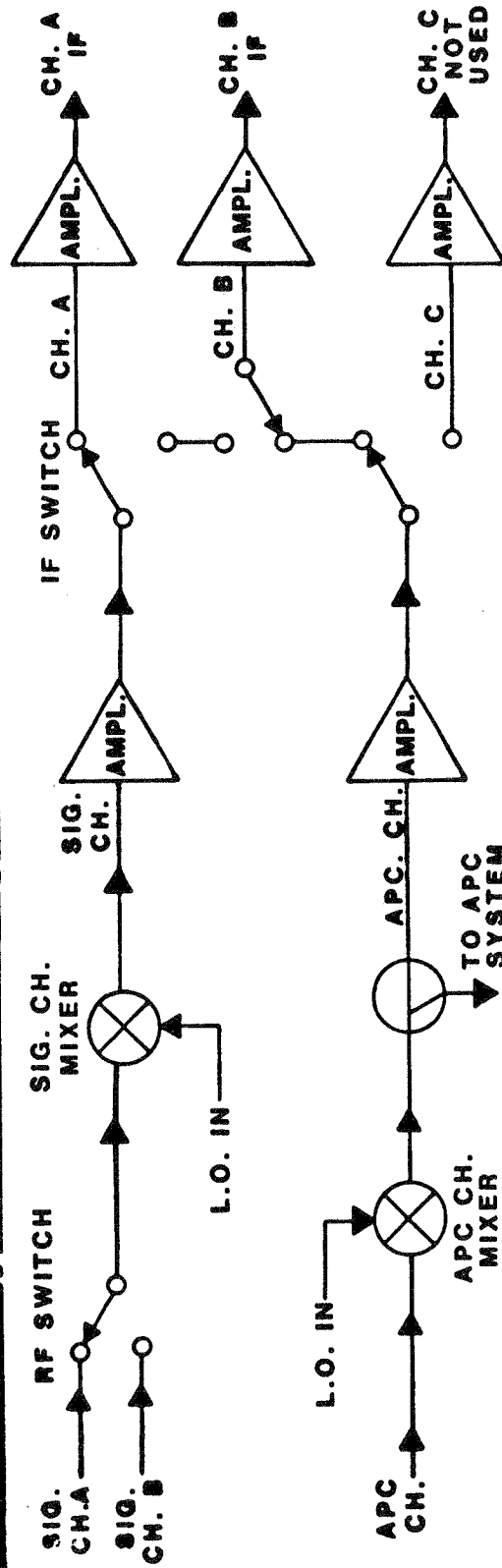

Figure 4B.

DUAL 2 (D2) MODE RF/IF CONNECTIONS, TWO OUTPUT CHANNELS.

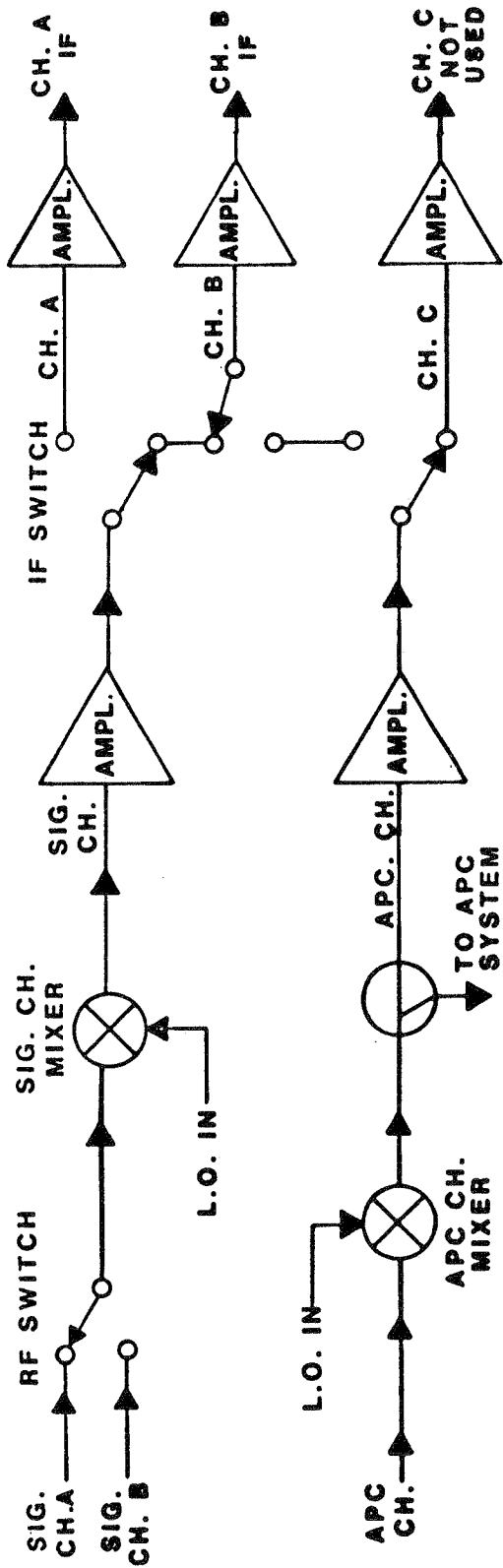

Figure 5A.

SHARED B MODE RF/IF CONNECTIONS, TWO OUTPUT CHANNELS

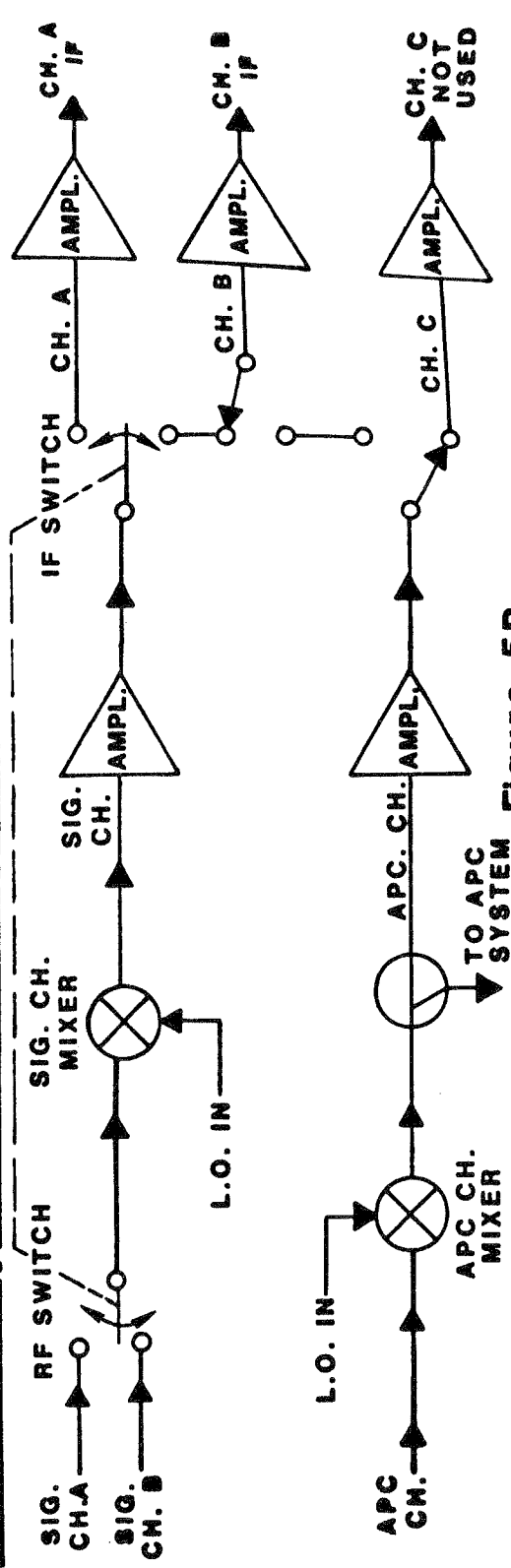

Figure 5B.

SHARED A/B MODE RF/IF CONNECTIONS, THREE OUTPUT CHANNELS

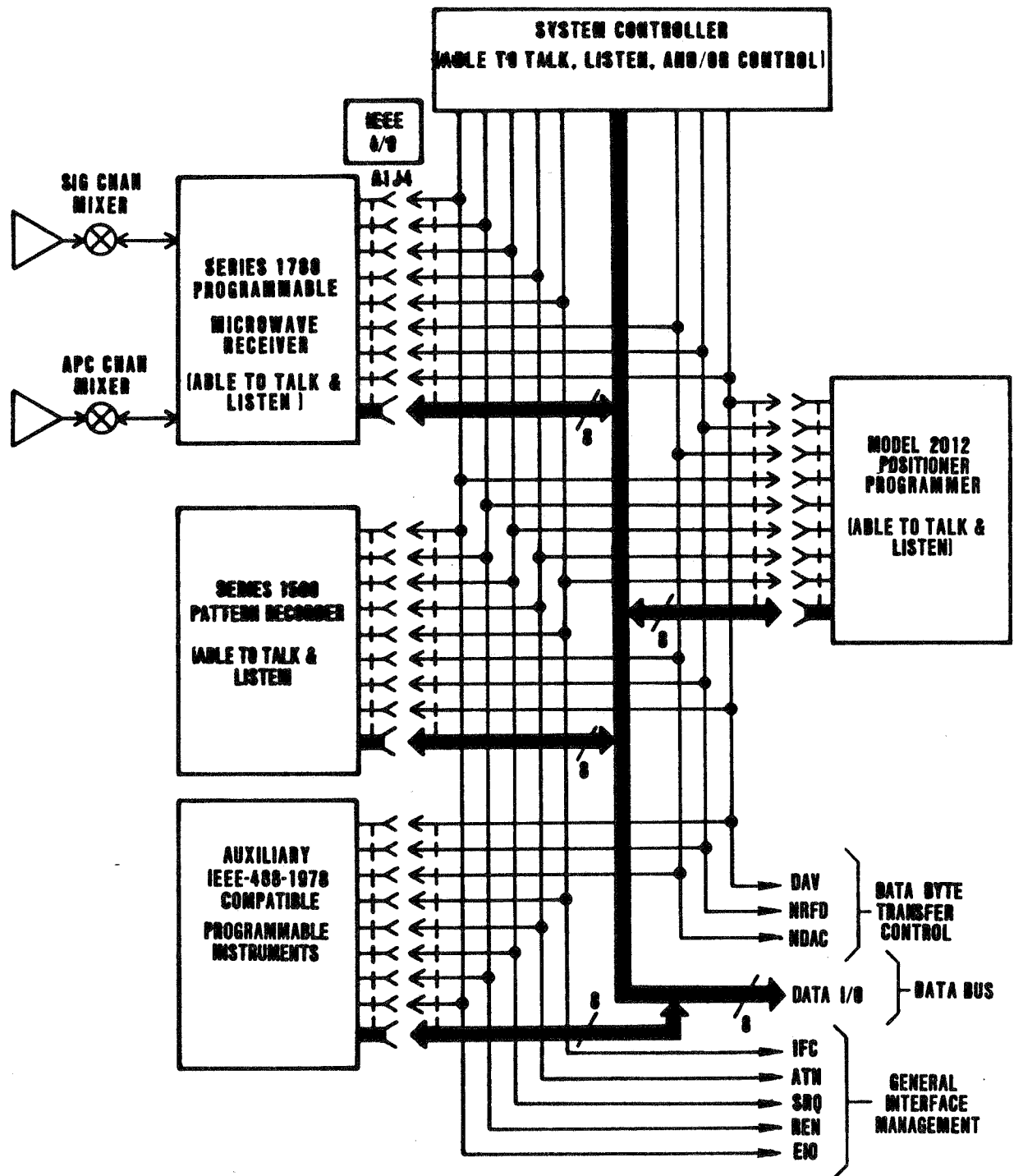

Figure 6. Series 1780 Programmable Microwave Receiver Connected to the IEEE-488-1978 Standard Data Bus

Search Width
APC ON/OFF
Bandwidth (Predetection Filtering)
Data Averaging (Post-Detection Filtering)
Display Functions
Remote or Local Tuning
Reference ON/OFF
Calibrate (IF System)
Recorder Output Select
Auto Zero
Preset (Phase and Amplitude)
Front Panel (Store Recall)

FREQUENCY RANGE

When the Series 1780 receiver is operated with the optional low-frequency converter (.1 to 1.0 GHz) and with optional fixed-tuned mixers, the receiver is programmable from 0.1 GHz to 100 GHz. Selection of operating frequency may be any of the following procedures.

- ... digital (manual) programming at receiver front panel.
- ... analog (remote) programming from Series 2150 signal source.
- ... digital (automatic) programming through the IEEE-488 standard bus.

When the Series 1780 receiver is operated in Scientific-Atlanta automatic systems, frequency programming is accomplished through the system signal source rather than through the IEEE-488 standard bus. When operated in this manner, the receiver remains phase-locked to the signal-source frequency during a frequency stepping interval. This eliminates the need to unlock, step frequency, search and relock the receiver to the signal source to each programmed frequency resulting in the shortest possible frequency step interval.

Frequency programming at frequencies above 18.0 GHz where mixer current readjustment may be necessary when frequency is changed is made possible by the ability of the receiver to store in memory up to ten complete front-panel programs. Each stored front-panel program can be preset for frequency, mixer current, attenuation settings, etc. These stored front-panel programs can be recalled either by manually using the receiver front-panel controls or automatically through the IEEE-488 standard bus.

An additional feature of the receiver is the `FREQ. RESET`, which automatically updates (corrects for signal source or receiver local oscillator frequency drift) each stored tuning command used to preset the local oscillator frequency prior to initiating phase-lock. This feature improves the frequency preset accuracy, reducing the search frequency range requirements necessary to provide phase lock. The local oscillator search range is programmable to be either zero or any 1 MHz increment between ± 10 MHz to ± 400 MHz. Since the product of peak-to-peak search width and search rate is a constant (approximately 2000 MHz/second), the narrower search-widths are associated with the higher scan rates. For a search width of ± 10 Hz the scan rate is 100 Hz and the average time to search and phase lock is 5 milliseconds (the worse-case time is 10 milliseconds).

REMOTE OPERATION DATA RATE

When the receiver is operated under remote control, the following two conditions occur:

- ... Receiver front panel controls are disabled.
- ... "REMOTE D" or "REMOTE F" is displayed on the receiver front panel.

"REMOTE D" indicates that data will be displayed on the receiver front panel while in REMOTE.

"REMOTE F" indicates that data will not be displayed on the receiver front panel while in REMOTE.

The "REMOTE F" mode is the fast mode, since data conversions for the front panel are not being performed. When operating in the "REMOTE F" mode, the receiver is capable of acquiring, sampling, processing and outputting multiple channel phase/amplitude data at rates of 100 or more data samples per second. The actual data rate is dependent on the REMOTE operating mode selected, the number of data channels being processed, the BANDWIDTH selected and the AVERAGED SAMPLES selected. (See Table 1.)

TABLE 1
MEASUREMENTS RESPONSE INTERVALS VS. BANDWIDTH

Bandwidth Code	Predetection Filtering 3 dB Bandwidth	Minimum Measurement Interval* (Milliseconds) for Avg. Sample = 1	
		For 2 Amp. Channels and the Corresponding Phase Channel	For 3 Amp. Channels and 2 Phase Channels (Phases A-C and B-C)
1	1600 Hz	9	11
2	550 Hz	11	13
3	400 Hz	21	25
4	200 Hz	29	38
5	110 Hz	47	60
6	55 Hz	81	105
7	27 Hz	155	195
8	14 Hz	295	383
9	7 Hz	575	755

*This is the minimum interval between Group Execute Triggers which will allow the receiver sufficient time for data settling data sampling, data processing, and data transfer.

For a 20 dB amplitude step occurring at a minimum interval of 2.0 milliseconds before the Group Execute Trigger, the measured value will be within 0.2 dB of the final amplitude value.

For a 90 degree phase step occurring at a minimum interval of 2.0 milliseconds before the Group Execute Trigger, the measured value will be within 0.1 degree of the final phase value.

BANDWIDTH AND AVERAGE SAMPLES

The Series 1780 Programmable Microwave Receiver offers a choice of nine bandwidths (7 Hz to 1600 Hz) and twelve selections of averaging of data samples (1 to 2048 samples averaged). When the system bandwidth is decreased, the sensitivity increases and response speed decreases. If bandwidth is increased, sensitivity decreases and response speed increases. When the number of data samples averaged is increased, the sensitivity is not affected; however, variance of the noise is decreased and the system response speed is decreased. If the number of data samples is decreased, less noise averaging occurs and the system response is increased.

The choice of operating bandwidth and average samples is determined by the system requirements for sensitivity and data rate. If maximum data rate is required, the widest BANDWIDTH (1) and the minimum AVERAGE SAMPLES should be selected. If, on the other hand, sensitivity and dynamic range are of primary importance, then the narrower bandwidths and greater number of AVERAGE SAMPLES should be selected. Table 2 shows the relationship between the BANDWIDTH code and the 3 dB predetection IF bandwidth.

TABLE 2
PREDETECTION 3 dB BANDWIDTH VS. BANDWIDTH CODE

<u>Bandwidth Code</u>	<u>Predetection IF Bandwidth 3 dB</u>
1	1600 Hz
2	550 Hz
3	400 Hz
4	200 Hz
5	110 Hz
6	55 Hz
7	27 Hz
8	14 Hz
9	7 Hz

Data averaging is possible by programming the receiver to average the measured data. Twelve AVERAGE SAMPLE levels are possible (1 through 12). Data averaging does not lower the system noise floor as does a bandwidth reduction; however, data averaging will reduce noise fluctuations, resulting in a smoothed average of the received data. The number of data samples averaged shown with the available AVERAGE SAMPLE choices is shown by Table 3.

TABLE 3
POST DETECTION 3 dB BANDWIDTH VS. AVERAGE SAMPLES CODE

<u>Average Sample Code</u>	<u>No. of Samples Averaged</u>	<u>Post Detection Bandwidth 3 dB</u>
1	1	1600 Hz
2	2	525 Hz
3	4	260 Hz
4	8	130 Hz
5	16	65 Hz
6	32	32 Hz
7	64	16 Hz
8	128	8 Hz
9	256	4 Hz
10	512	2 Hz
11	1024	1 Hz
12	2048	0.5 Hz

The versatility afforded by the ability to program the receiver BANDWIDTH is illustrated by Figure 7. This is a plot of the operating dynamic range of the signal channel versus selections of bandwidth for one averaged data sample. As shown, the receiver can be programmed to function as a high-data-rate acquisition system (BANDWIDTHS 1, 2, or 3), a moderate data-rate acquisition system (BANDWIDTHS 4 through 6) or a low-data-rate, wide dynamic range system (BANDWIDTHS 7, 8 or 9).

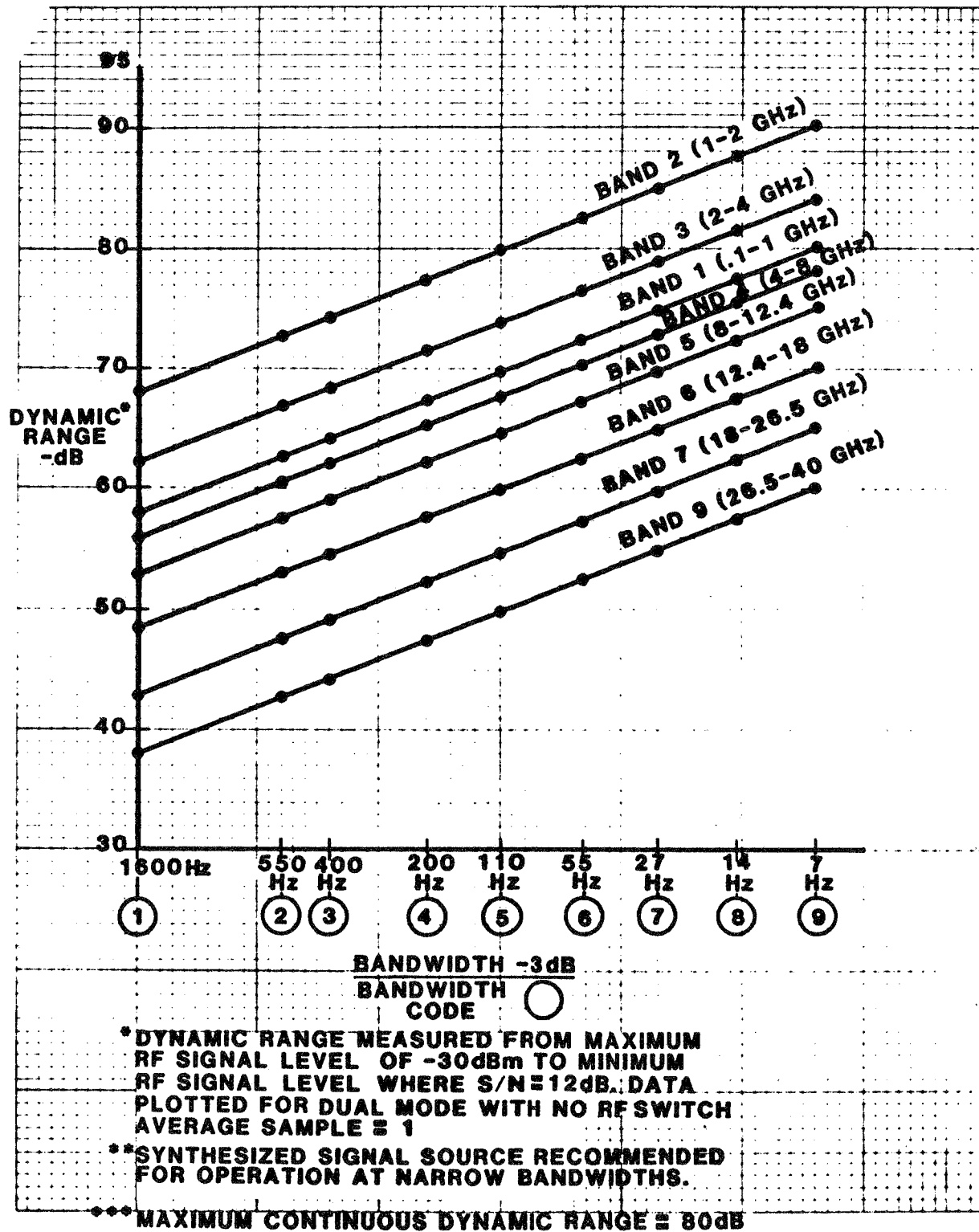

Figure 7. Signal Channel Operating Dynamic Range vs Predetection Bandwidth Selection

IF SYSTEM

The IF modules of the Series 1780 receiver have been designed using integrated circuit amplifiers as the basic amplifier gain stages. All main IF amplifiers are powered from power sources that are double-regulated. These design factors have resulted in an IF system with excellent gain and phase stability versus temperature and power line voltage change and phase-tracking between channels.

The phase and amplitude stability of the IF system is further improved by a programmable calibration procedure. A stable, coherent 45.000 MHz signal is supplied to the inputs of the SIG CH and APC CH IF preamplifiers as a calibration reference. An automatic calibration routine calibrates phase and amplitude of each IF channel in one-dB amplitude steps over a 40-dB dynamic range. Error correction is performed digitally. The entire calibration procedure for three amplitude channels and two phase channels is accomplished in approximately ten seconds.

Each IF channel and corresponding amplitude data output has a continuous operating dynamic range of 80 dB with an 0.01 dB resolution over the full 80 dB dynamic range. The resolution of the phase data readout is 0.1 degree.

The attenuation of each IF channel is programmable in 1.0 dB steps over a 40 dB dynamic range. Programmable phase presets and amplitude presets permit amplitude and phase channel output data to be preset to desired reference levels. An AUTO ZERO procedure automatically adjusts the output reading of any phase or amplitude channel to full scale (00.00 dB log amplitude or 000.0 degrees phase).

SUMMARY

The new Series 1780 Programmable Phase/Amplitude Receiver is a versatile microprocessor-based data acquisition receiver offering many new features and

capabilities including IEEE-488 standard bus compatibility, high data rate capability, programmable IF system bandwidth, programmable data averaging, programmable IF system calibration, improved amplitude and phase stability, and an 80 dB continuous dynamic range with a .01 dB resolution.

These features allow the receiver to be programmed to provide optimum performance for a wide variety of manual and automatic antenna range measurement situations.