

AMTA
Sept. 1983

A DUAL-PORTED, DUAL-POLARIZED SPHERICAL NEAR-FIELD PROBE

J. R. Jones and D. P. Hardin
Scientific-Atlanta, Inc.

Spherical near-field testing of antennas requires the acquisition of a great volume of data. In general, to compute the far-field of the antenna under test in any direction requires the acquisition of data at sample intervals related to the size of the antenna under test over a spherical sampling surface completely enclosing the antenna under test. This data must also be sampled as a function of probe orientation. Even for the simplest possible case, two probe orientations (or two probes) must be used.

Acquisition of this much data takes a long time. The requirement that data be acquired as a function of probe orientation is particularly troublesome, since acquiring data for even two probe orientations doubles the time required for data acquisition. In 1979, F. H. Larsen¹ demonstrated the feasibility of using a dual-polarized, dual-ported spherical near-field probe. Such a probe makes possible the acquisition of spherical near-field data for two probe orientations in a single scan. The development of a broadband, dual-ported, dual-polarized antenna which could be used as a spherical near-field probe was the goal of the efforts reported herein.

The specifications desired for the dual-polarized spherical near-field probe were based on our experience at Scientific-Atlanta with single-ported probes. Maintaining adequate RF power was known to be a problem even in a near-field test with a single-ported probe. Therefore, in order to minimize the mismatch loss associated with the dual-ported probe, its VSWR was constrained to be less than 2.0:1 over the entire band of operation. Then, use of the probe with the Scientific-Atlanta model 1780 receiver's RF sharing switch, which would be required for dual-ported operation, and which itself exhibits a 2.0:1 VSWR, would cause no more than 1.94 dB of mismatch loss.²

The dual-ported probe was required to have an axially-symmetric aperture. This aperture was to be excited by a single TE_{11} waveguide mode propagating in the circular waveguide. Such a probe responds to a single, linearly-polarized component of the electric field. If the aperture of the probe is small enough, the probe, to a good approximation, responds, to the electric field at a point in a near-field test, meaning that the pattern of the probe has a negligible effect on the computed far field. Also, it is with such a probe, the pattern of which depends on the azimuthal angle χ_0 in the same way as that of an ideal elemental dipole, that measurements as a function of azimuthal angle χ_0 are required for only two probe orientations, or for only one for a dual-polarized probe. Figure 1 illustrates the coordinate systems used in spherical near-field scanning.

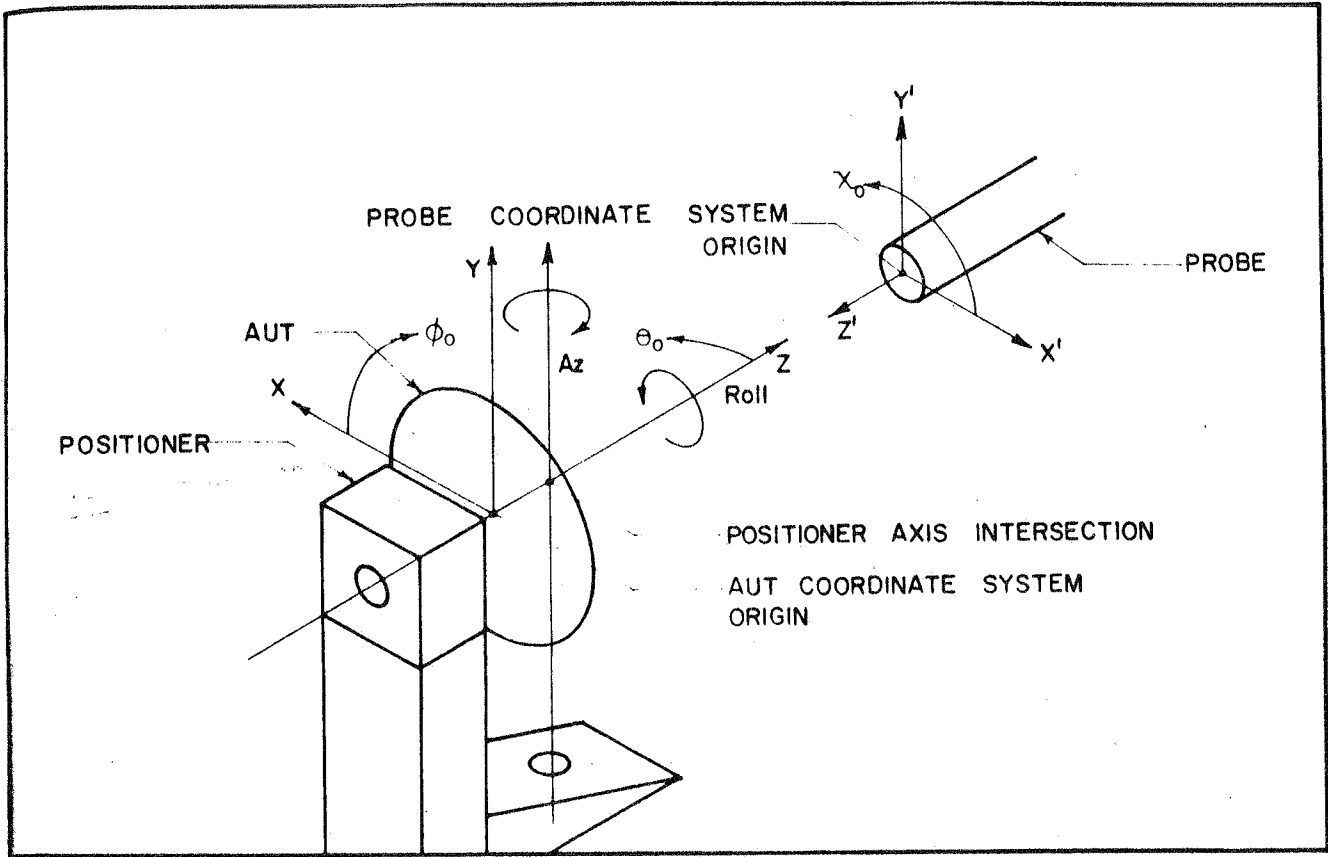

Figure 1. Coordinate Systems for Spherical Near-Field Scanning

A set of five probes, each operating over a standard rectangular waveguide bandwidth, was to be designed. Single-mode operation in circular waveguide over the bandwidth of a rectangular waveguide is impossible. The ratio of the cutoff frequency of the first higher-order mode (the TM_{01} mode) in circular waveguide to the cutoff frequency of the fundamental TE_{11} mode is 1.306. In a rectangular waveguide such as WR-62 (Ku-band waveguide, 12.4-18 GHz), the ratio of the highest frequency of operation to the lowest frequency of operation (which is higher than the cutoff frequency of the fundamental TE_{10} mode) is 1.452. In practice, however, a device with no abrupt discontinuities can propagate only a single waveguide mode even where propagation of other modes is possible because energy is transferred into higher-order modes at discontinuities.³ It was required that the dual-ported probes operate in this manner.

The dual-ported probes were required to radiate fields with high axial ratios (35 dB). For a probe of the type described above, the axial ratio is highly dependent on the roundness of the circular waveguide. The probes were thus required to have a high degree of roundness. A probe with a high axial ratio is required to avoid the necessity of correcting data measured with it for polarization effects. An axial ratio for the probe of 35 dB appears to yield far-field patterns which are in good agreement with far-field patterns measured on the Compact Range for the co-polarized component of the field. Agreement of the cross-polarized component is far more difficult to achieve, and a broadband probe with a sufficiently high axial ratio to yield good agreement in the cross-polarized component would be extremely difficult to fabricate.

The final design of the dual-polarized probes is shown in Figure 2. It is similar to that of the ultra-bandwidth finline

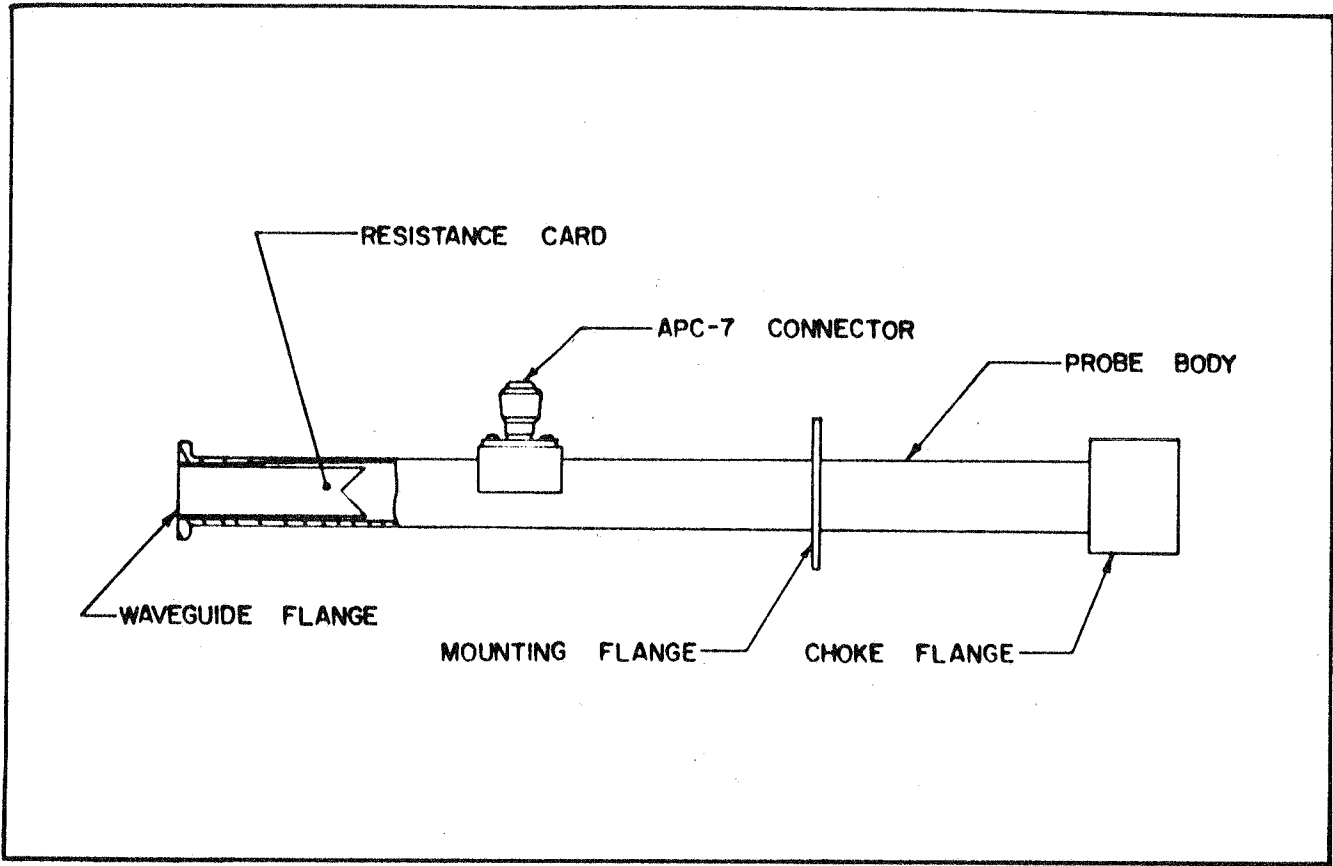

Figure 2. Dual-Polarized Spherical Near-Field Probe

coupler reported by S. D. Robertson in 1955,⁴ with the addition of an integral coax-to-waveguide adapter at the side port. A photograph of an electroformed prototype of this probe appears in Figure 3. The APC-7 connector and the mounting flange have been added to the final design since this prototype was fabricated. The APC-7 connector provides a repeatable, easily-defined reference plane for the measurement of the reflection coefficient of the probe (which may be desired for precise gain measurements) and the mounting flange provides a method for mounting the probe which will not, in gripping the probe, squeeze it out of round.

Figure 4 shows the results of return loss measurements as a function of frequency at the side (coax) port of the probe. The return loss is related to the magnitude of the reflection coefficient ρ by

$$L_R(\text{dB}) = 10 \log_{10} \rho^2 \quad (1)$$

and the magnitude of the reflection coefficient ρ is related to the VSWR S by

$$\rho = \frac{S - 1}{S + 1} \quad (2)$$

From equation (2), a 2.0:1 VSWR corresponds to a reflection coefficient magnitude $\rho = .333$. This yields, by equation (1), a return loss of 9.54 dB. As the figure indicates, the probe meets the 2.0:1 VSWR specification over the entire band of operation from 12.4-18 GHz.

The isolation of the two input ports of the probe was found to be greater than 40 dB over the entire band of operation, and the axial ratio of the waves excited at each port was greater than 35 dB over the whole band. In each of these "bench" tests, the

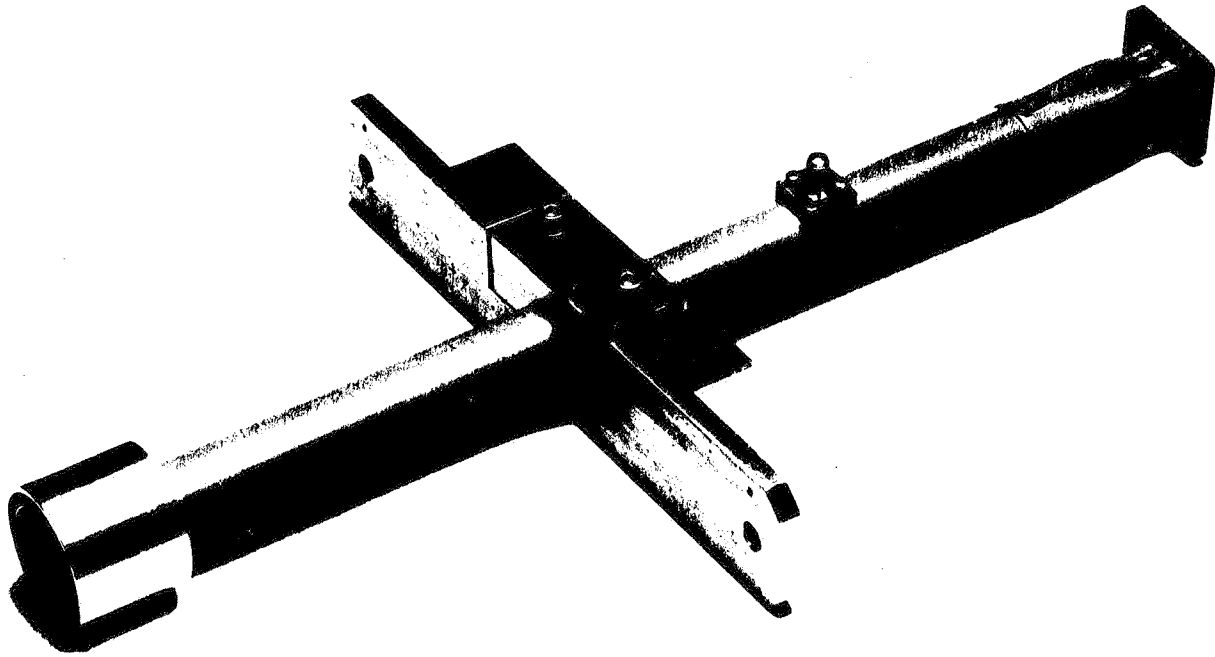

Figure 3. Electroformed prototype of dual-polarized spherical near field probe.

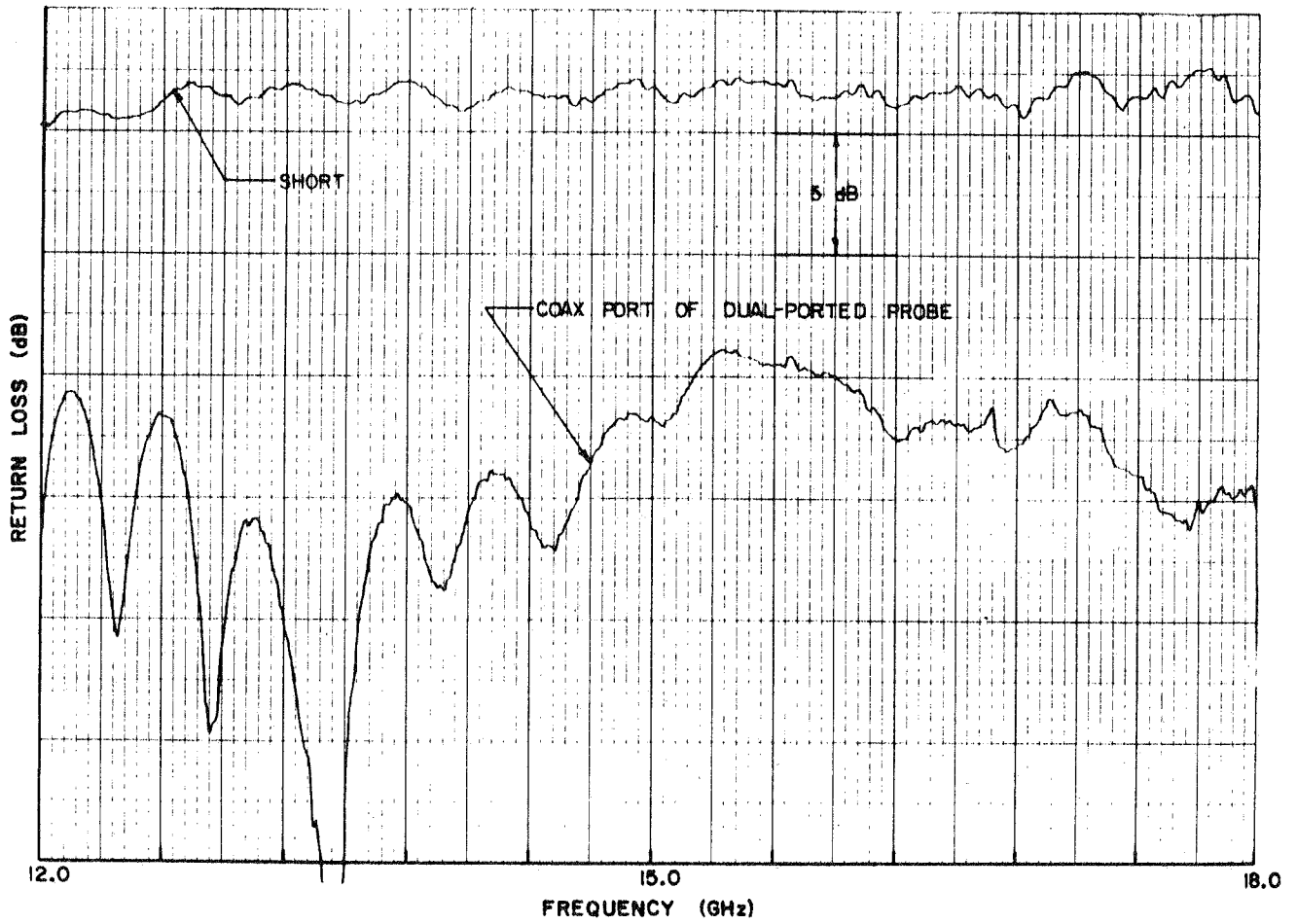

Figure 4. Return Loss on Coax Port of Dual-Polarized Spherical Near-Field Probe

near-field probe met the design specifications. The next test attempted was use of the probe in a near-field test.

Figures 5-8 document the results of the near-field tests performed with the dual-ported probe. These figures are comparisons of the pattern for a standard antenna measured using the spherical near-field technique with the dual-polarized spherical near-field probe and using the compact range technique. Figure 5 is a comparison for the co-polarized component with the antenna mounted in equatorial mount (main beam on the equator of the measurement sphere).⁵ Figure 6 shows the comparison in the cross-polarized component for this mounting configuration. Figure 7 is a comparison for the co-polarized component with the antenna mounted in polar mount (main beam on the north pole of the measurement sphere). Figure 8 shows the comparison in the cross-polarized component for this mounting configuration. These measurements were made a frequency of 13 GHz because a great deal of information about the pattern at 13 GHz of the test antenna used was available.

The efforts reported herein resulted in the design and fabrication of a broadband dual-ported; dual-polarized spherical near-field probe. This probe demonstrates a 2.0:1 VSWR at both ports over the entire band of operation. The waves radiated by the probe are highly linearly-polarized (axial ratio of 35 dB) and highly orthogonal (isolation of >40 dB). The waves excited at the two ports of the probe exhibit radiation patterns which are somewhat different. When these patterns are decomposed into of spherical modes, the coefficients of the various spherical modes appear to agree to within about 10%. It is unknown whether this degree of agreement is sufficient to allow for the correction of the effects of the probe pattern on the computed far-field pattern. It is known, however, that the probe can be used to

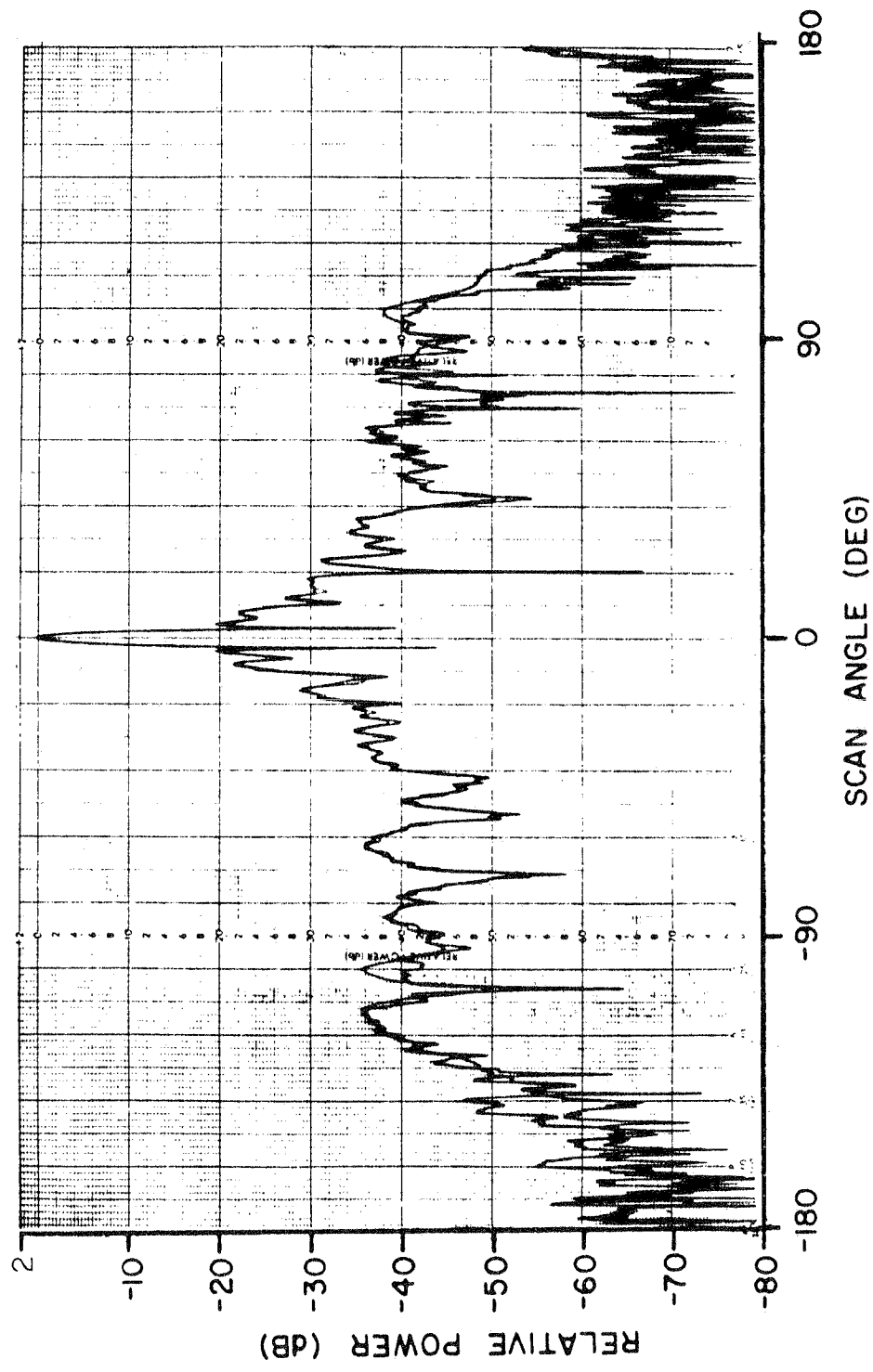

Figure 5. Spherical near-field measurements with the dual-ported probe vs. compact range measurements. Antenna under test is mounted in equatorial orientation. Data is for co-polarized component.

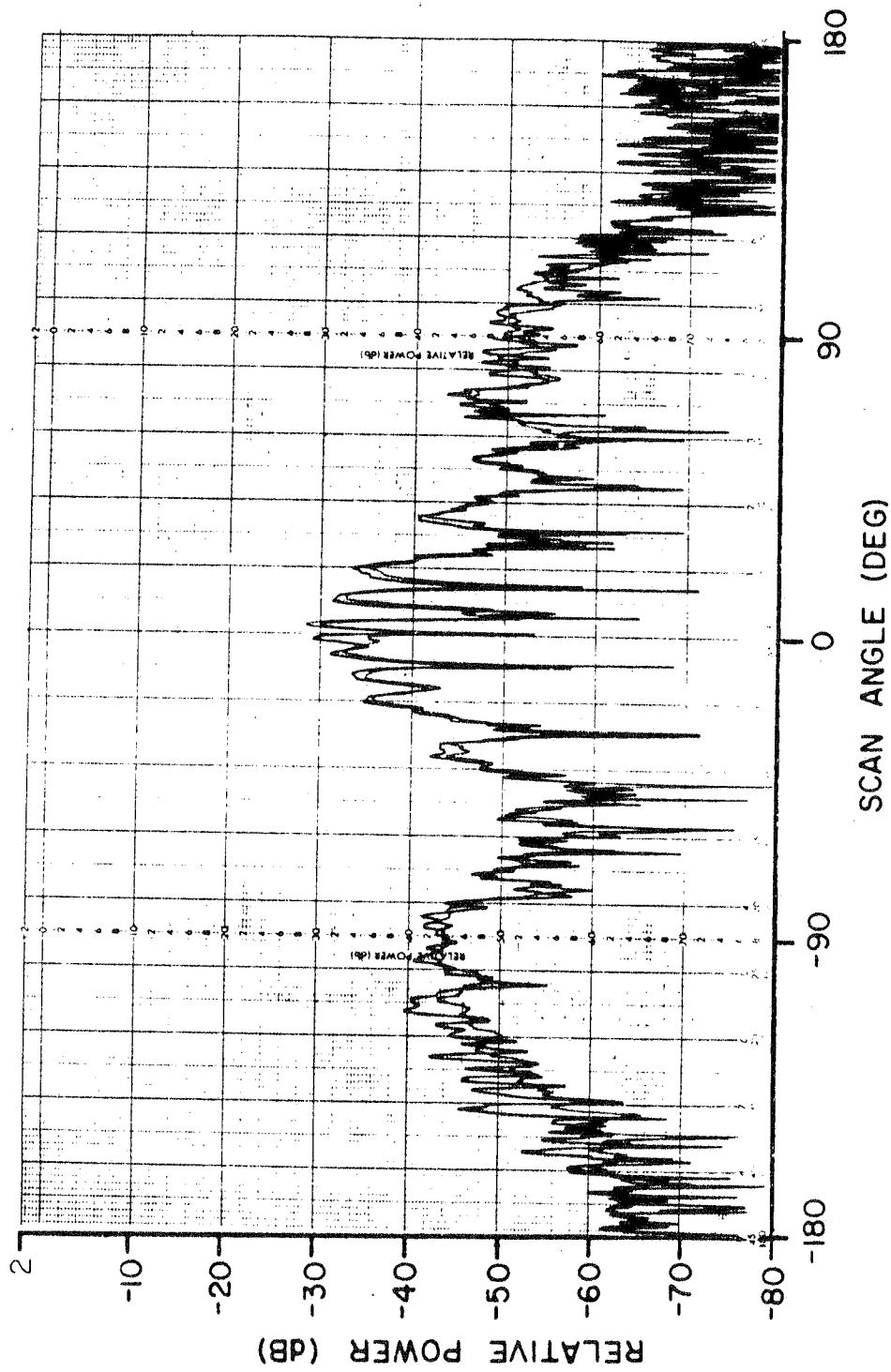

Figure 6. Spherical near-field measurements with the dual-ported probe vs. compact range measurements. Antenna under test is mounted in equatorial orientation. Data is for cross-polarized component.

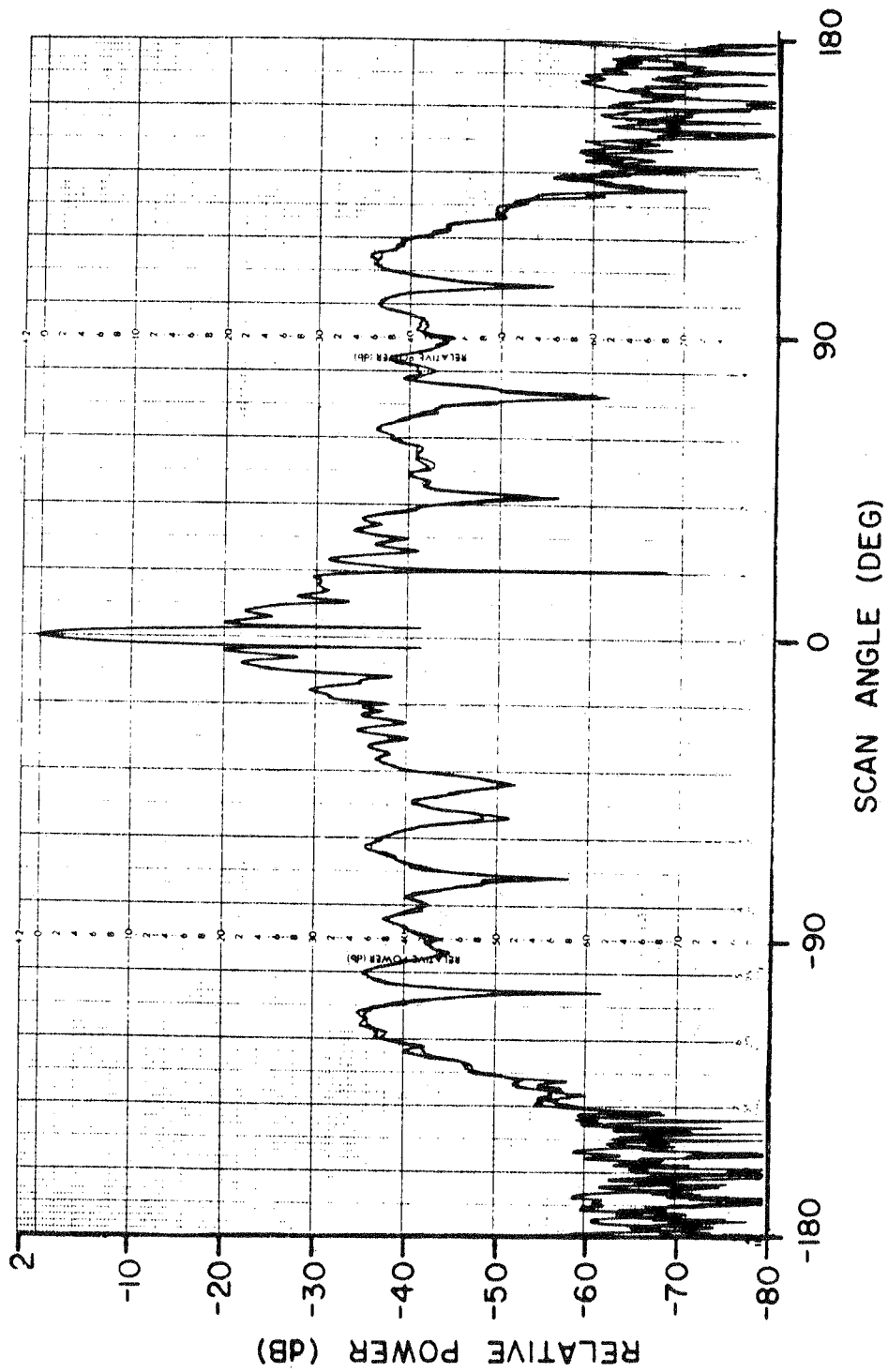

Figure 7. Spherical near-field measurements with the dual-ported probe vs. compact range measurements. Antenna under test is mounted in polar orientation. Data is for co-polarized component.

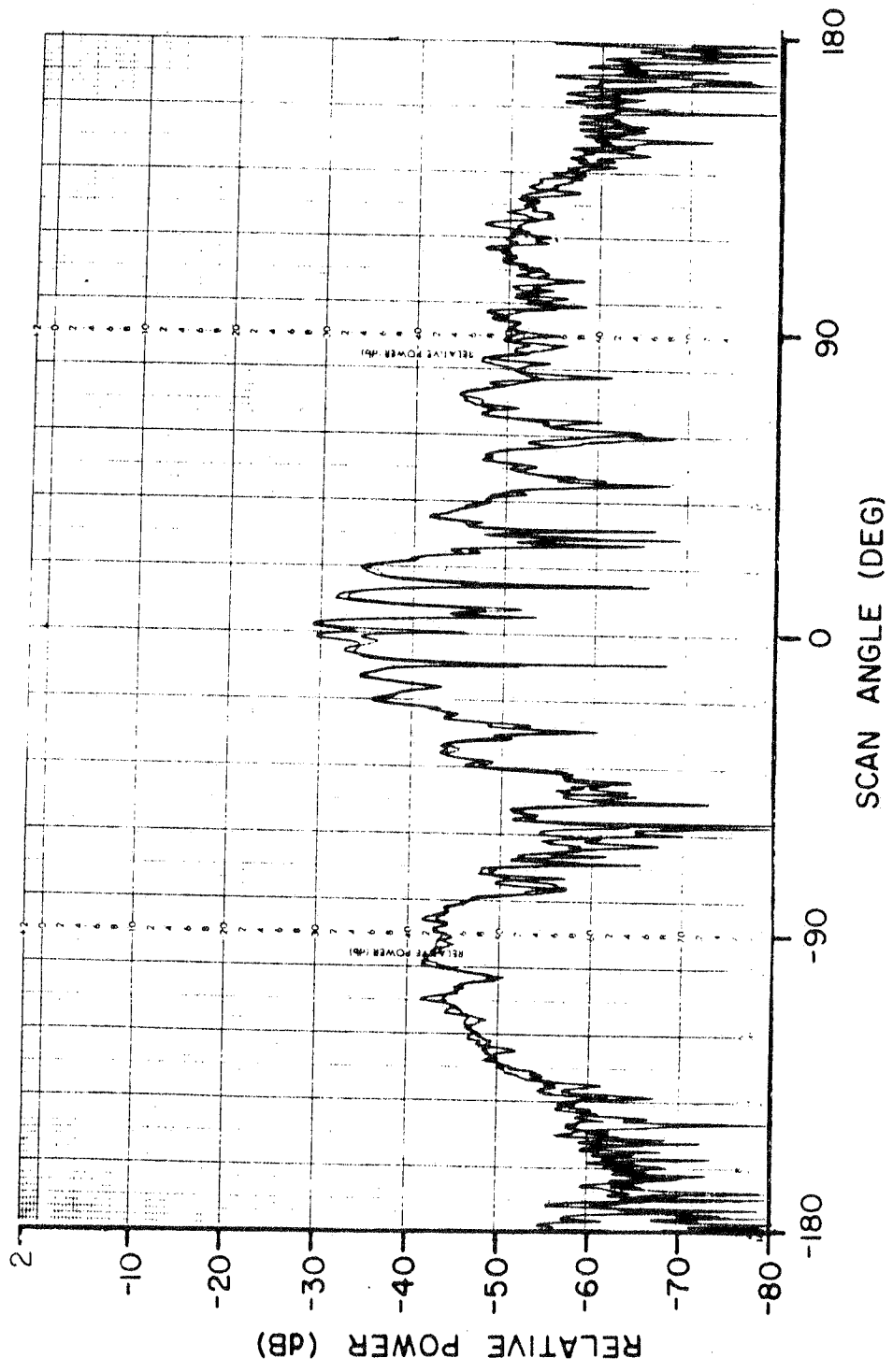

Figure 8. Spherical near-field measurements with the dual-ported probe vs. compact range measurements. Antenna under test is mounted in polar orientation. Data is for cross-polarized component.

acquire data for non-probe corrected measurements with an accuracy comparable to that attainable with a single-ported probe.

REFERENCES

1. Larsen, F. H. and Hansen, J. E., "A Dual-Polarized Probe System for Near-Field Measurements", presented at IEEE Int. Symp. on Ant. Prop., Seattle, WA, 1979.
2. Kerns, D. M. and Beatty R. W., Basic Theory of Waveguide Junctions and Introductory Microwave Network Analysis, Pergamon Press, New York, NY, 1967, p. 56.
3. Collin, R. E., Foundations for Microwave Engineering, McGraw-Hill, Inc., New York, NY, 1966, p. 112.
4. Robertson, S. D., "The Ultra-Bandwidth Finline Coupler", IRE Trans. Microwave Theory and Tech., Vol. 3, 1955, pp. 45-48.
5. Spherical Near-Field Range Configuration, Scientific-Atlanta, Inc., 1982, p. 4-5.

A DUAL-PORTED, DUAL-POLARIZED SPHERICAL NEAR-FIELD PROBE

J. R. Jones and D. P. Hardin
Scientific-Atlanta, Inc.

Spherical near-field testing of antennas requires the acquisition of a great volume of data. In general, to compute the far-field of the antenna under test in any direction requires the acquisition of data at sample intervals related to the size of the antenna under test over a spherical sampling surface completely enclosing the antenna under test. This data must also be sampled as a function of probe orientation. Even for the simplest possible case, two probe orientations (or two probes) must be used.

Acquisition of this much data takes a long time. The requirement that data be acquired as a function of probe orientation is particularly troublesome, since acquiring data for even two probe orientations doubles the time required for data acquisition. In 1979, F. H. Larsen¹ demonstrated the feasibility of using a dual-polarized, dual-ported spherical near-field probe. Such a probe makes possible the acquisition of spherical near-field data for two probe orientations in a single scan. The development of a broadband, dual-ported, dual-polarized antenna which could be used as a spherical near-field probe was the goal of the efforts reported herein.

The specifications desired for the dual-polarized spherical near-field probe were based on our experience at Scientific-Atlanta with single-ported probes. Maintaining adequate RF power was known to be a problem even in a near-field test with a single-ported probe. Therefore, in order to minimize the mismatch loss associated with the dual-ported probe, its VSWR was constrained to be less than 2.0:1 over the entire band of operation. Then, use of the probe with the Scientific-Atlanta model 1780 receiver's RF sharing switch, which would be required for dual-ported operation, and which itself exhibits a 2.0:1 VSWR, would cause no more than 1.94 dB of mismatch loss.²

The dual-ported probe was required to have an axially-symmetric aperture. This aperture was to be excited by a single TE_{11} waveguide mode propagating in the circular waveguide. Such a probe responds to a single, linearly-polarized component of the electric field. If the aperture of the probe is small enough, the probe, to a good approximation, responds, to the electric field at a point in a near-field test, meaning that the pattern of the probe has a negligible effect on the computed far field. Also, it is with such a probe, the pattern of which depends on the azimuthal angle χ_0 in the same way as that of an ideal elemental dipole, that measurements as a function of azimuthal angle χ_0 are required for only two probe orientations, or for only one for a dual-polarized probe. Figure 1 illustrates the coordinate systems used in spherical near-field scanning.

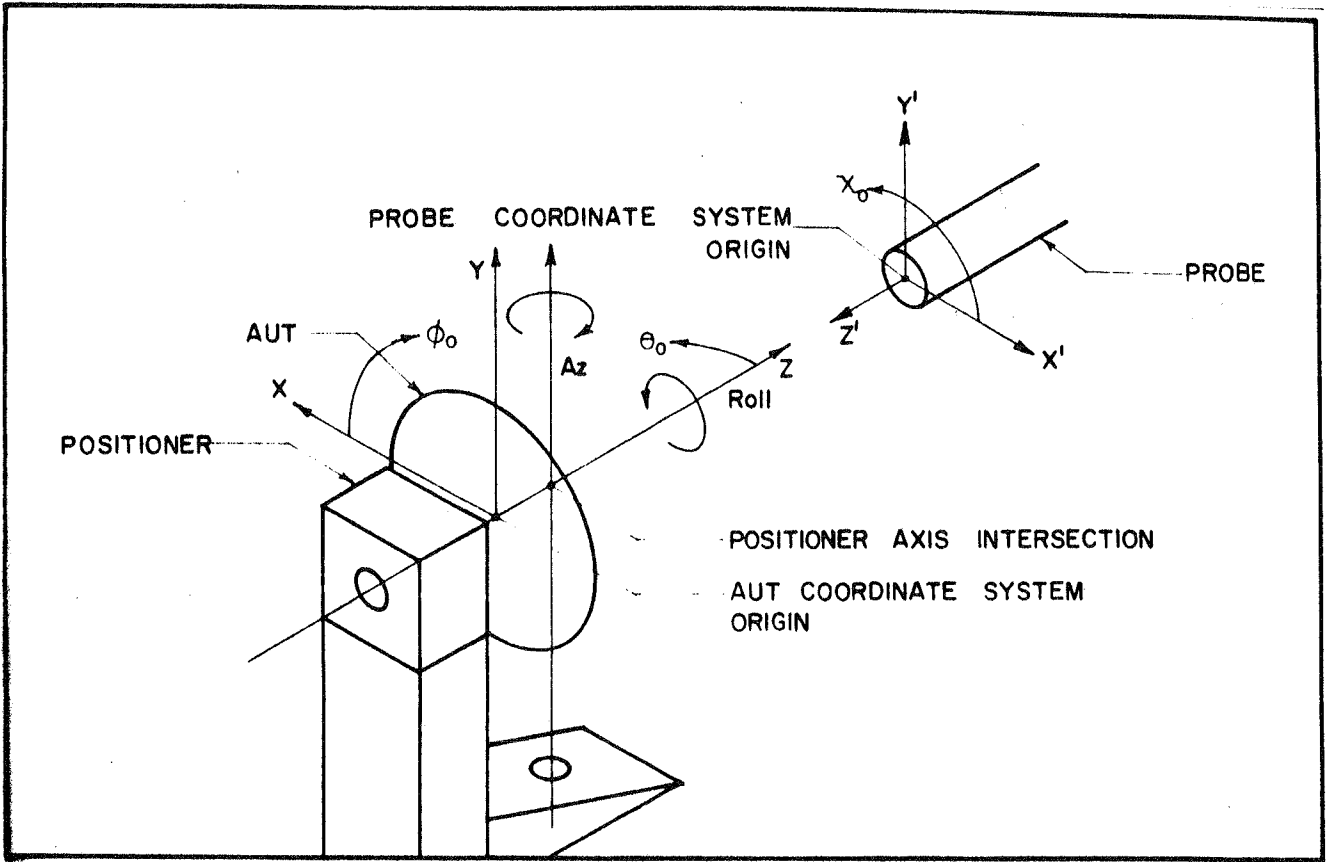

Figure 1. Coordinate Systems for Spherical Near-Field Scanning

A set of five probes, each operating over a standard rectangular waveguide bandwidth, was to be designed. Single-mode operation in circular waveguide over the bandwidth of a rectangular waveguide is impossible. The ratio of the cutoff frequency of the first higher-order mode (the TM_{01} mode) in circular waveguide to the cutoff frequency of the fundamental TE_{11} mode is 1.306. In a rectangular waveguide such as WR-62 (Ku-band waveguide, 12.4-18 GHz), the ratio of the highest frequency of operation to the lowest frequency of operation (which is higher than the cutoff frequency of the fundamental TE_{10} mode) is 1.452. In practice, however, a device with no abrupt discontinuities can propagate only a single waveguide mode even where propagation of other modes is possible because energy is transferred into higher-order modes at discontinuities.³ It was required that the dual-ported probes operate in this manner.

The dual-ported probes were required to radiate fields with high axial ratios (35 dB). For a probe of the type described above, the axial ratio is highly dependent on the roundness of the circular waveguide. The probes were thus required to have a high degree of roundness. A probe with a high axial ratio is required to avoid the necessity of correcting data measured with it for polarization effects. An axial ratio for the probe of 35 dB appears to yield far-field patterns which are in good agreement with far-field patterns measured on the Compact Range for the co-polarized component of the field. Agreement of the cross-polarized component is far more difficult to achieve, and a broadband probe with a sufficiently high axial ratio to yield good agreement in the cross-polarized component would be extremely difficult to fabricate.

The final design of the dual-polarized probes is shown in Figure 2. It is similar to that of the ultra-bandwidth finline

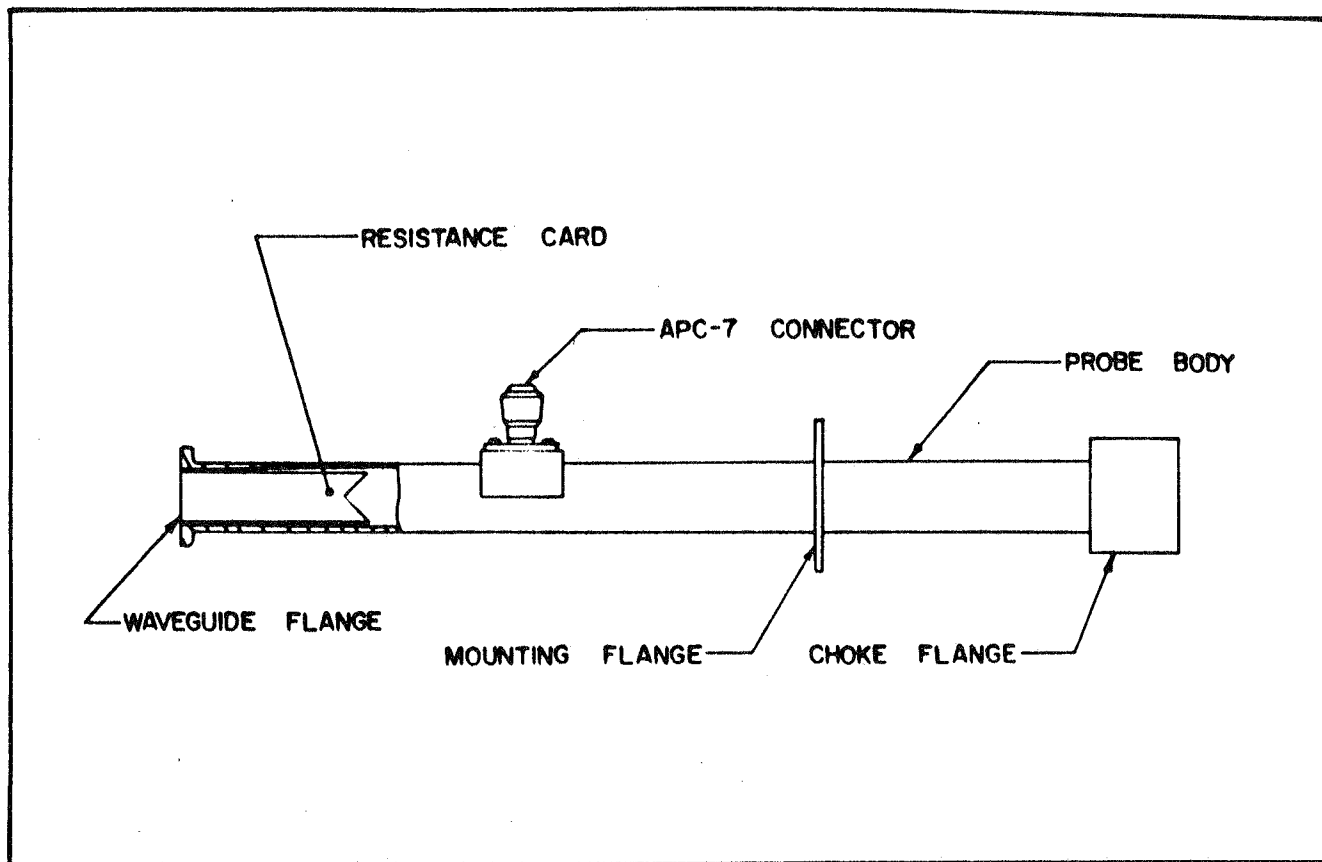

Figure 2. Dual-Polarized Spherical Near-Field Probe

coupler reported by S. D. Robertson in 1955,⁴ with the addition of an integral coax-to-waveguide adapter at the side port. A photograph of an electroformed prototype of this probe appears in Figure 3. The APC-7 connector and the mounting flange have been added to the final design since this prototype was fabricated. The APC-7 connector provides a repeatable, easily-defined reference plane for the measurement of the reflection coefficient of the probe (which may be desired for precise gain measurements) and the mounting flange provides a method for mounting the probe which will not, in gripping the probe, squeeze it out of round.

Figure 4 shows the results of return loss measurements as a function of frequency at the side (coax) port of the probe. The return loss is related to the magnitude of the reflection coefficient ρ by

$$L_R(\text{dB}) = 10 \log_{10} \rho^2 \quad (1)$$

and the magnitude of the reflection coefficient ρ is related to the VSWR S by

$$\rho = \frac{S - 1}{S + 1} \quad (2)$$

From equation (2), a 2.0:1 VSWR corresponds to a reflection coefficient magnitude $\rho = .333$. This yields, by equation (1), a return loss of 9.54 dB. As the figure indicates, the probe meets the 2.0:1 VSWR specification over the entire band of operation from 12.4-18 GHz.

The isolation of the two input ports of the probe was found to be greater than 40 dB over the entire band of operation, and the axial ratio of the waves excited at each port was greater than 35 dB over the whole band. In each of these "bench" tests, the

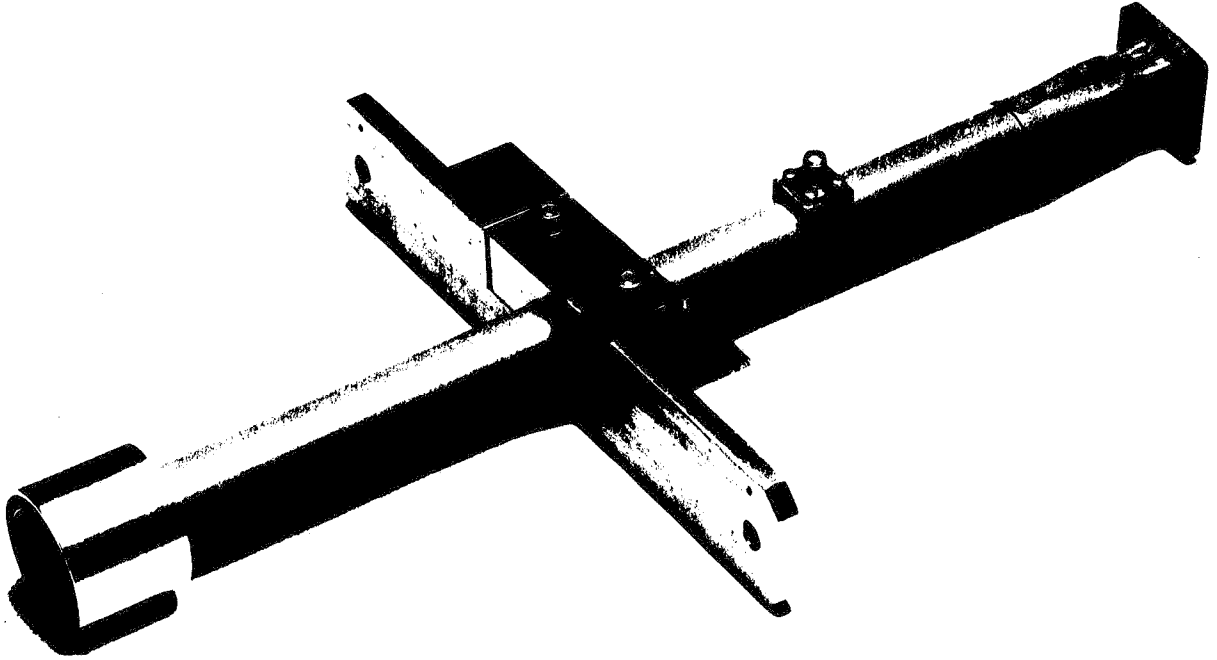

Figure 3. Electroformed prototype of dual-polarized spherical near field probe.

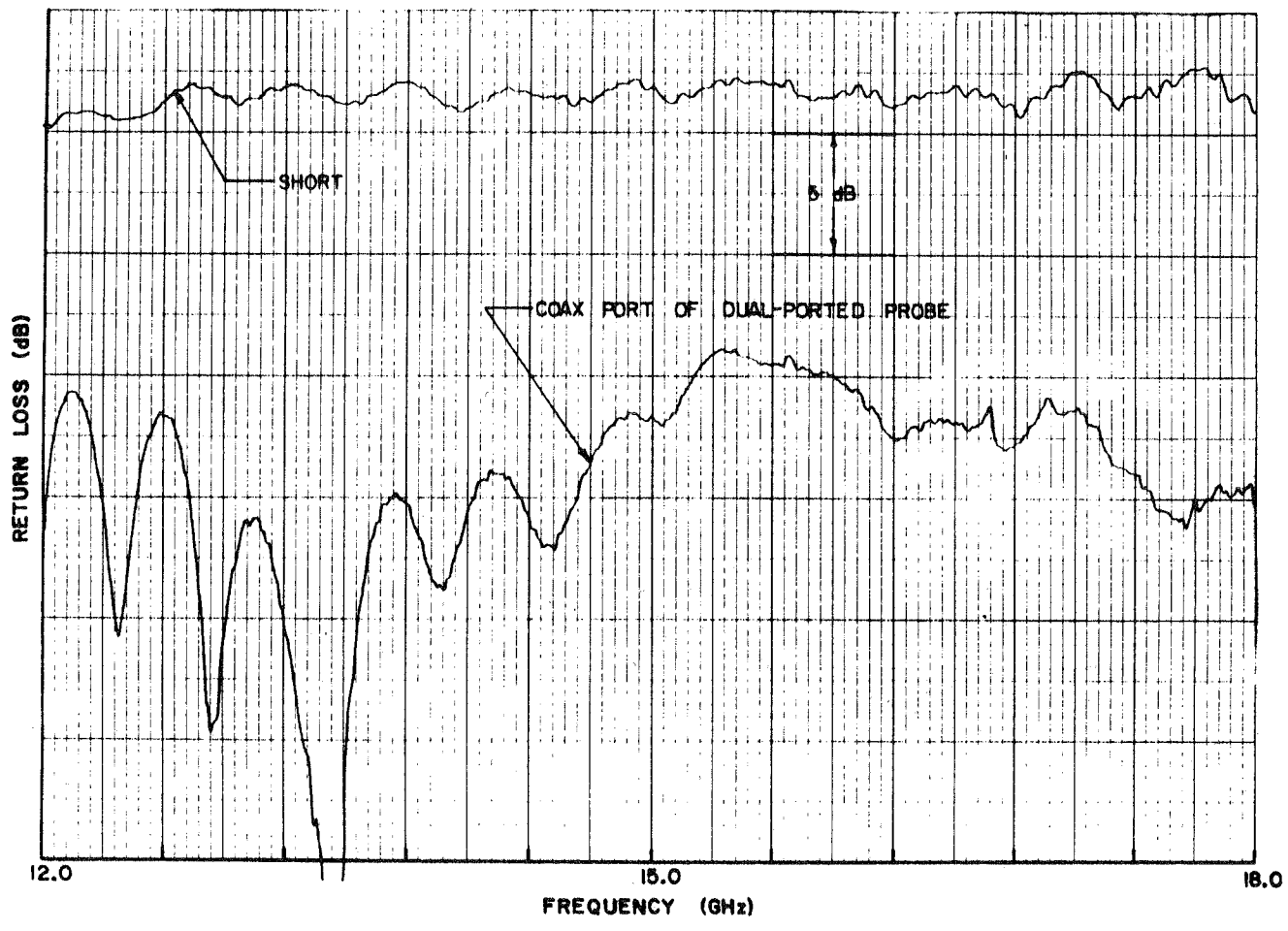

Figure 4. Return Loss on Coax Port of Dual-Polarized Spherical Near-Field Probe

near-field probe met the design specifications. The next test attempted was use of the probe in a near-field test.

Figures 5-8 document the results of the near-field tests performed with the dual-ported probe. These figures are comparisons of the pattern for a standard antenna measured using the spherical near-field technique with the dual-polarized spherical near-field probe and using the compact range technique. Figure 5 is a comparison for the co-polarized component with the antenna mounted in equatorial mount (main beam on the equator of the measurement sphere).⁵ Figure 6 shows the comparison in the cross-polarized component for this mounting configuration. Figure 7 is a comparison for the co-polarized component with the antenna mounted in polar mount (main beam on the north pole of the measurement sphere). Figure 8 shows the comparison in the cross-polarized component for this mounting configuration. These measurements were made a frequency of 13 GHz because a great deal of information about the pattern at 13 GHz of the test antenna used was available.

The efforts reported herein resulted in the design and fabrication of a broadband dual-ported; dual-polarized spherical near-field probe. This probe demonstrates a 2.0:1 VSWR at both ports over the entire band of operation. The waves radiated by the probe are highly linearly-polarized (axial ratio of 35 dB) and highly orthogonal (isolation of >40 dB). The waves excited at the two ports of the probe exhibit radiation patterns which are somewhat different. When these patterns are decomposed into of spherical modes, the coefficients of the various spherical modes appear to agree to within about 10%. It is unknown whether this degree of agreement is sufficient to allow for the correction of the effects of the probe pattern on the computed far-field pattern. It is known, however, that the probe can be used to

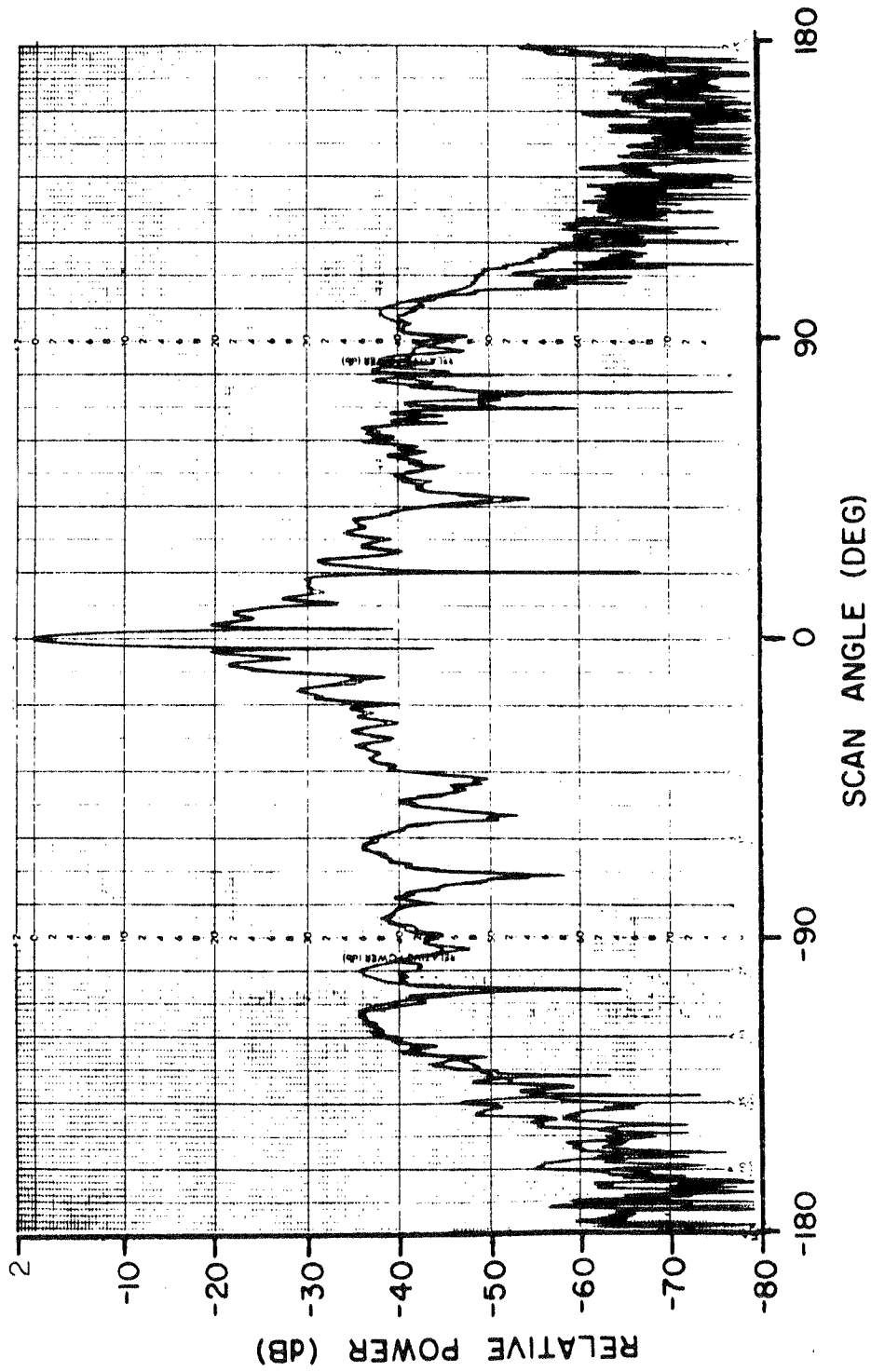

Figure 5. Spherical near-field measurements with the dual-ported probe vs. compact range measurements. Antenna under test is mounted in equatorial orientation. Data is for co-polarized component.

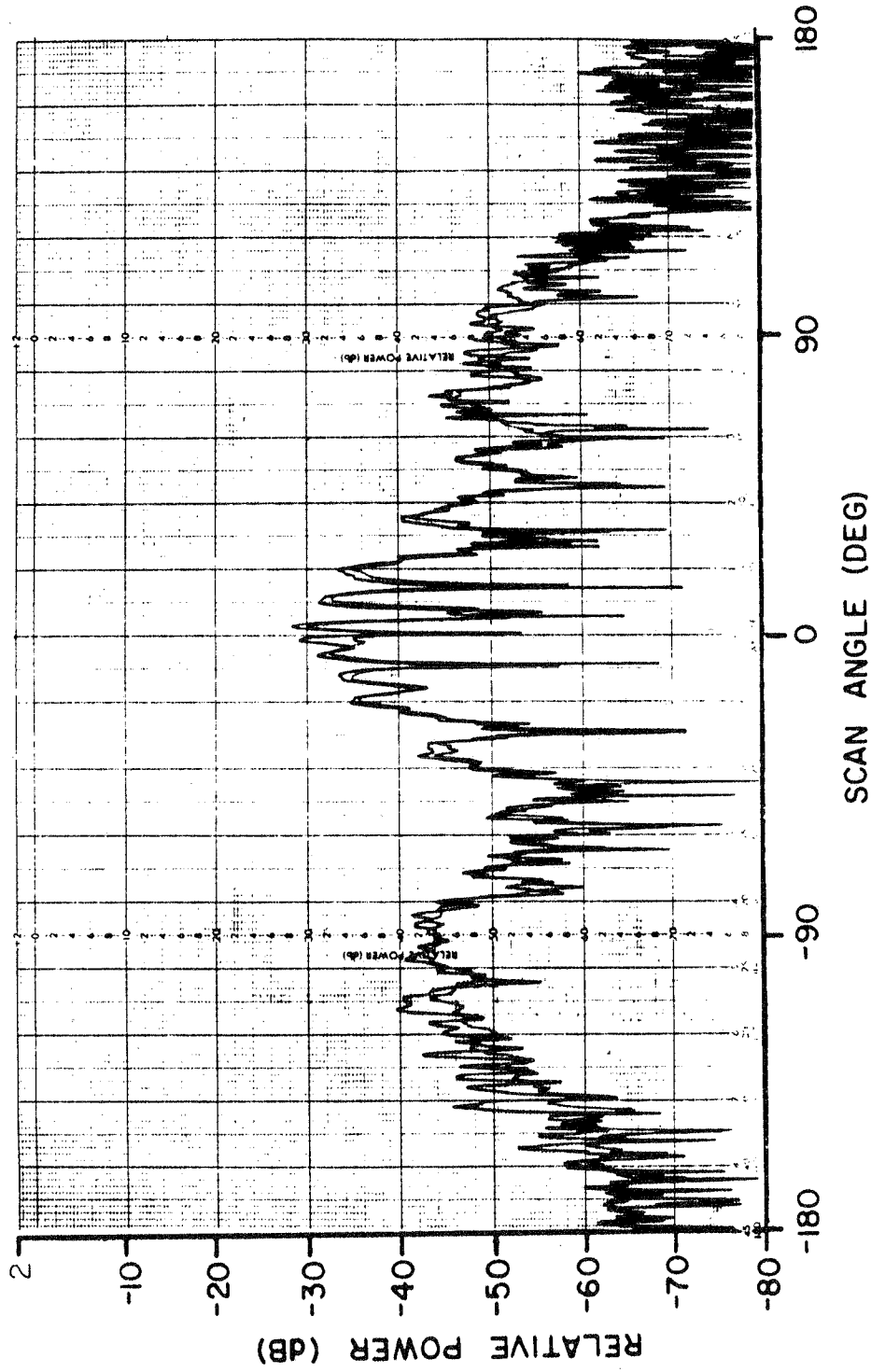

Figure 6. Spherical near-field measurements with the dual-ported probe vs. compact range measurements. Antenna under test is mounted in equatorial orientation. Data is for cross-polarized component.

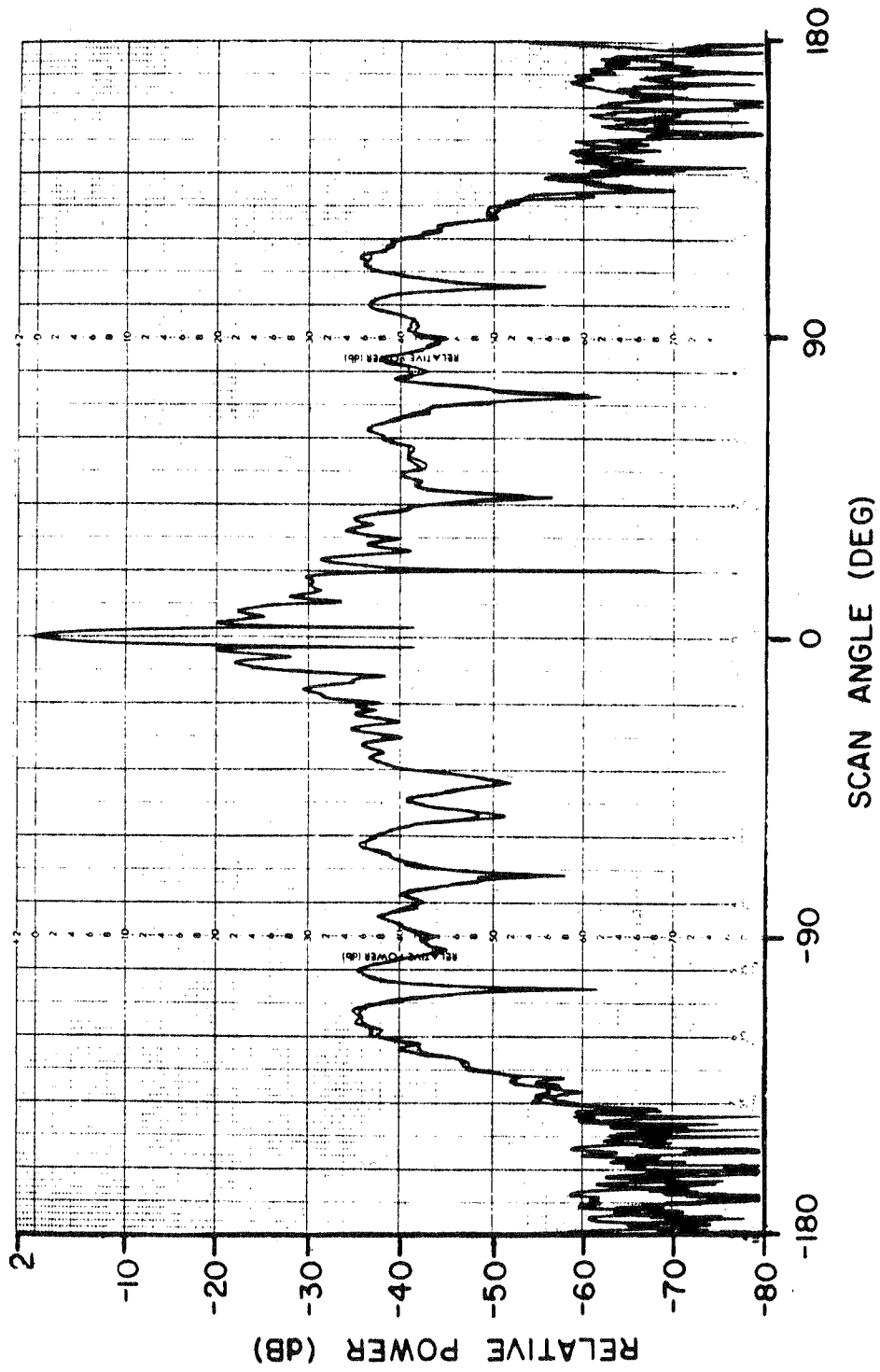

Figure 7. Spherical near-field measurements with the dual-ported probe vs. compact range measurements. Antenna under test is mounted in polar orientation. Data is for co-polarized component.

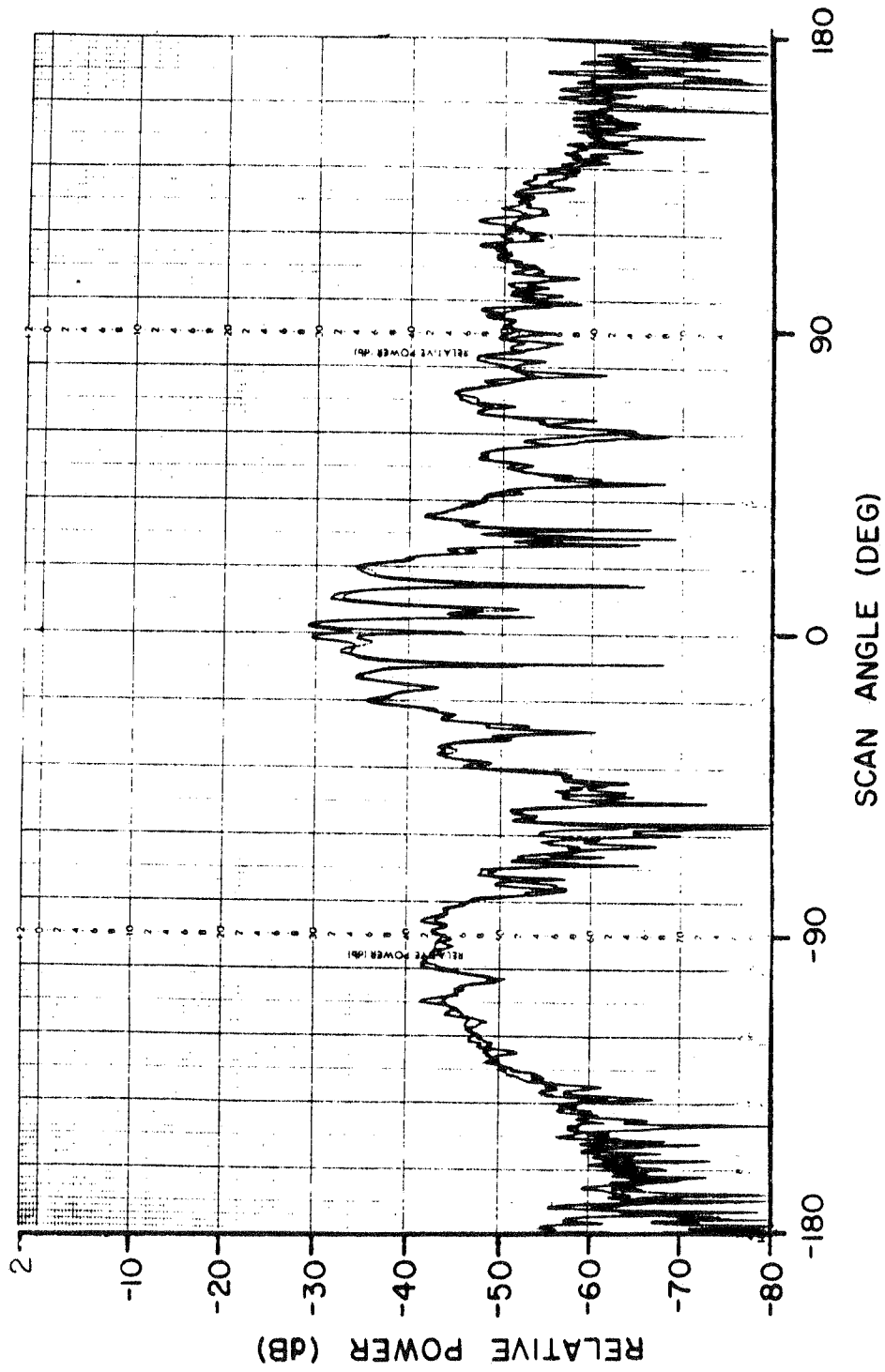

Figure 8. Spherical near-field measurements with the dual-ported probe vs. compact range measurements. Antenna under test is mounted in polar orientation. Data is for cross-polarized component.

acquire data for non-probe corrected measurements with an accuracy comparable to that attainable with a single-ported probe.

REFERENCES

1. Larsen, F. H. and Hansen, J. E., "A Dual-Polarized Probe System for Near-Field Measurements", presented at IEEE Int. Symp. on Ant. Prop., Seattle, WA, 1979.
2. Kerns, D. M. and Beatty R. W., Basic Theory of Waveguide Junctions and Introductory Microwave Network Analysis, Pergamon Press, New York, NY, 1967, p. 56.
3. Collin, R. E., Foundations for Microwave Engineering, McGraw-Hill, Inc., New York, NY, 1966, p. 112.
4. Robertson, S. D., "The Ultra-Bandwidth Finline Coupler", IRE Trans. Microwave Theory and Tech., Vol. 3, 1955, pp. 45-48.
5. Spherical Near-Field Range Configuration, Scientific-Atlanta, Inc., 1982, p. 4-5.