

ELECTROMAGNETIC RADOME MEASUREMENTS: A REVIEW OF AUTOMATED SYSTEMS

Doren W. Hess⁽¹⁾, Robert Luna⁽²⁾, John McKenna⁽³⁾
MI Technologies

*1125 Satellite Boulevard, Suite 100
Suwanee, GA 30024 USA*

⁽¹⁾*dhess@mi-technologies.com*, ⁽²⁾*rluna@mi-technologies.com*, ⁽³⁾*jmckenna@mi-technologies.com*

Abstract

Characterization of radome performance involves measuring the radome-induced changes in the microwave signals that are transmitted and received by the antenna through the radome. The standard quantities that characterize a radome's performance are Beam Deflection, Boresight Shift, Transmission Efficiency, Change in Antenna Reflection Characteristic, and Pattern Distortion. Typical test system configurations include an RF subsystem and a mechanical positioning subsystem interfaced to a host computer. In this paper we review three types of radome test systems that have been implemented recently – far-field range, compact range, and near-field scanning ranges. We point out the salient features of each. We note the importance of digital automation to making these measurements practical.

Keywords: Radome Measurements, Radome Measurement Systems, Near-Field Scanning Radome Measurements

1. Introduction

The term *radome* originated as a contraction of the term *radar dome* – the covering over a ground-based radar antenna to protect it from environmental elements. Presumably, the presence of the radome does not prevent the radar from operating satisfactorily. When the radar is mounted on an aircraft the radome surface serves additionally as a windfoil, integrated into the design of the airframe. Now that radar deployment has become commonplace, the performance characteristics of radomes have often been taken for granted by all but the experts specialized in antenna design. Meanwhile, the term radome has come to mean any covering over any type of microwave antenna. To quantify the performance of a radome, engineers employ the following measures:

Beam Deflection (BD)
Boresight Shift (BS)
Transmission Efficiency (TE)

Antenna Reflection Characteristic,
Pattern Distortion

These are now standard measures of antenna radome performance [1], [2]. With these measures, an engineer can differentiate between acceptable radome performance and unacceptable.

Beam Deflection is the change in the direction of propagation of the microwave signal as it passes through the radome. For test antennas with a tracking null, the term *boresight shift* is often used interchangeably with *beam deflection*. Then *beam deflection* can be a term reserved for the case of a sum beam.

Transmission Efficiency is the percentage of microwave energy that passes through a radome. It is typically measured over various angular regions. It is measured by comparing power levels received by a test antenna in two different conditions: First, with the radome installed to cover the antenna, and second, without the radome. Losses, as the signal passes through the radome are due to a combination of reflection, diffraction, absorption, refraction, and depolarization. The definition of transmission efficiency neglects multipath effects among the radome, test positioner, and test antenna. These effects are assumed to have been acceptably reduced or eliminated by careful design.

Radome Reflectivity Characteristic is the change in the magnitude of the reflection coefficient at the port of the antenna brought about by the presence of the radome is measured by a reflectometer with a remote head. The

reflection coefficient is measured before and after the radome is installed with the antenna pointing out into a reflectionless environment such as a chamber or an outdoor range.

Pattern Distortion is the change or difference between the antenna pattern of the uncovered antenna and the antenna pattern of the composite object that consists of the antenna together with its covering radome.

2. Relationship Between the Range Source, the Antenna and the Radome

To understand the nature of radome testing and its attendant complexity, consider the relationship between the antenna and the radome. Figure 1 is a schematic of the antenna alone consisting of a radiating structure and a port. To define completely the pattern of the antenna, we set up a fiducial coordinate system for reference. The entire radiation pattern is usually measured in step-scan fashion, scanning one of the direction angles while stepping the other. Next consider a schematic of the radome alone as in Figure 2. Again a fiducial coordinate system is used to assist in defining the orientation of the radome. The radome is measured by assessing its effect upon the radiation pattern of the associated antenna.

Now consider, as in Figure 3, the combination of the antenna and radome together, each in an arbitrary orientation as they might be in general applications. The origin of the complexity of radome testing becomes apparent. For each variation in the relative geometric relationship of the radome to the antenna, a two-dimensional step-scan pattern must be measured to characterize the composite object's radiation pattern.

In Figure 4 below, a simple schematic of a radome test range is shown. As in the case of many such ranges, here the signal originates at the remote range site where a transmitter is located, producing the planar wavefront illuminating the radome receive site. The range is shown with the wavefront aligned to the peak of the deflected sum beam. In practice, the alignment can be attained either by reorienting the wavefront or the antenna under the radome.

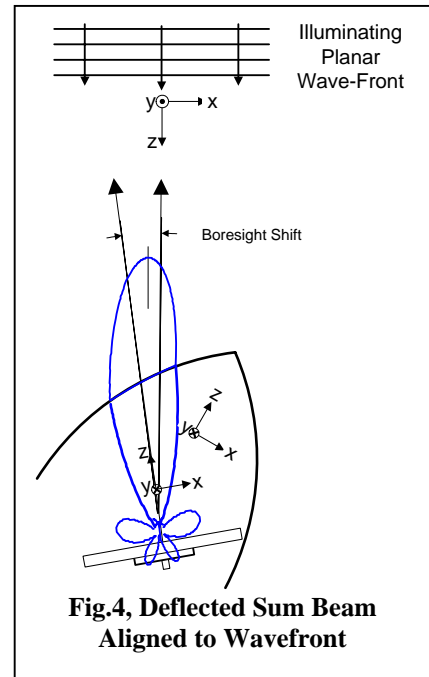
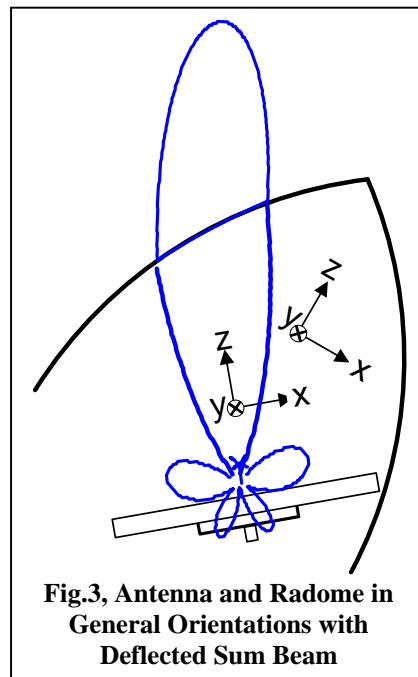
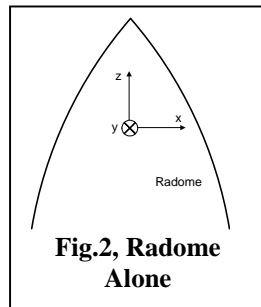
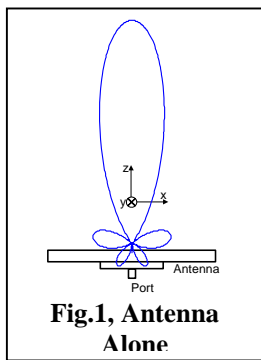

3. Automatic Boresight Alignment for Measurement of Beam Deflection

To accomplish the alignment of the range boresight two methods have been devised. The older traditional method is to place the range transmitter on an x-y positioner and to translate it in a plane that is perpendicular to the range axis [1]. This of course has the effect of steering the angles of arrival of the wavefront relative to the laboratory coordinate system. A pair of tracking control loops can accomplish this alignment if feedback is provided for the

received signal. If the received signal is from a difference pattern, the x-y positioner is often termed a *null-seeker*. If the received signal is from a sum beam, a pair of horns illuminating the test zone with a pair of planar wavefronts is carried by the x-y positioner and the control loop seeks to balance the corresponding pair of received amplitudes. In this case the x-y positioner is termed a *beam-straddler*. Please see Figure 5 for a photograph of a modern x-y positioner that has been used in this application.

A second method of achieving alignment between the illuminating wavefront and the radiation pattern of the antenna is to employ a tracking gimbal positioner under the antenna. The gimbal has two mechanically steered axes – Yaw and Pitch – that can be driven by positioning control loops. The received signal is a pair of difference patterns, each with a null on boresight. The yaw and pitch axes seek and hold the orientation of the antenna to the local wavefront at the antenna. A photograph of a gimbal positioner is shown in Fig. 6, with a flat plate array antenna mounted on it.

These two approaches differ in the degree of difficulty of implementation and the generality of the test approach. The far-field x-y positioner is a more general approach that can be applied to a larger class of radomes. To implement a gimbal system the mass characteristics of the antenna must be conducive to designing a gimbal positioner with sufficient angular speed and angular readout accuracy to meet the needs of the measurements. Fitting a gimbal underneath a radome requires specialized engineering that is often expensive to implement. The gimbal also takes up room underneath the radome preventing as full a range of relative motion as is desired.



Fig.5, An x-y Positioner Used as Null Seeker



Fig.6, A Yaw/Pitch Gimbal Positioner

4. Radome Positioners

Radome positioners can take several different forms depending on whether two- or three-axis radome motion is to be realized. A photograph of a recently designed three-axis roll/elevation/azimuth radome positioner is shown in Figure 7. This mounts and rotates the radome.

An illustration of a similar radome positioner together with the antenna mounting helpful to understanding the positioning system is shown in Figure 8. Under the radome, the antenna is mounted on a Yaw/Pitch gimbal over an antenna Roll axis. In this particular implementation, the Roll in turn is fix-mounted on the same azimuth axis turntable as the radome. In this figure, the radome axes are Roll/EI/Az. (There is a longitudinal translation axis underneath



Fig.7, Three-Axis Radome Positioner

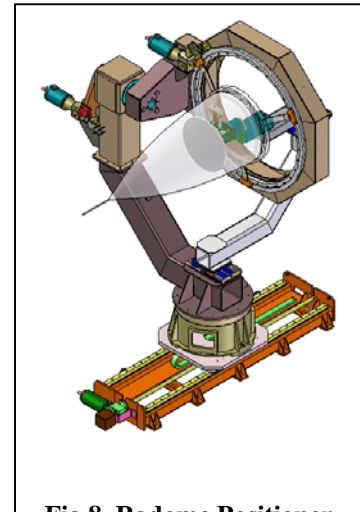

Fig.8, Radome Positioner with Antenna Mount and Auxiliary Floor Slide

the entire antenna-radome positioning system.) Each of the three rotational axes for the antenna, and each of the three rotational axes for the radome is controlled by the mechanical positioning subsystem.

5. System for Far-Field Radome Testing

Transmission efficiency and beam deflection may be measured with a single receiver by sequentially switching between ports of the tracking antenna. To measure beam deflection, the antenna positioner actively tracks the boresight of the illuminating wavefront, first without the radome and then with it installed. A basic test system includes a control computer, transmit signal source, source positioner, radome positioner, positioner control equipment, test antenna, radio frequency (RF) signal multiplexer, and receiver. The receiver serves a duality of uses; that is, it is configured either to provide a tracking signal for beam deflection or to extract amplitude data for transmission efficiency testing.

The test antenna positioner is typically a two-axis gimbal assembly. The test antenna must be a tracking antenna that operates using one of the usual techniques such as monopulse differences, conical scanning, or sequential lobing. Transmission efficiency data can be acquired from the sum channel vs radome position data.

An architecture for beam deflection and transmission efficiency that employs two separate receivers is shown in Figure 9. Receiver #1 processes TE data while receiver #2 processes BD data. Receiver #2 (the tracking receiver) requires three signal inputs from the tracking antenna: sum, delta azimuth, and delta elevation.

The sum channel RF signal is coupled to receiver #1 directly and passed to receiver #2 via the multiplexer. Receiver #1 processes the sum channel signal, extracting the amplitude data required for TE measurements. Receiver #2 processes the sum channel, delta azimuth channel, and delta elevation channel signals, generating the tracking errors required for BD measurements. Receivers #1 and #2 operate simultaneously and independently.

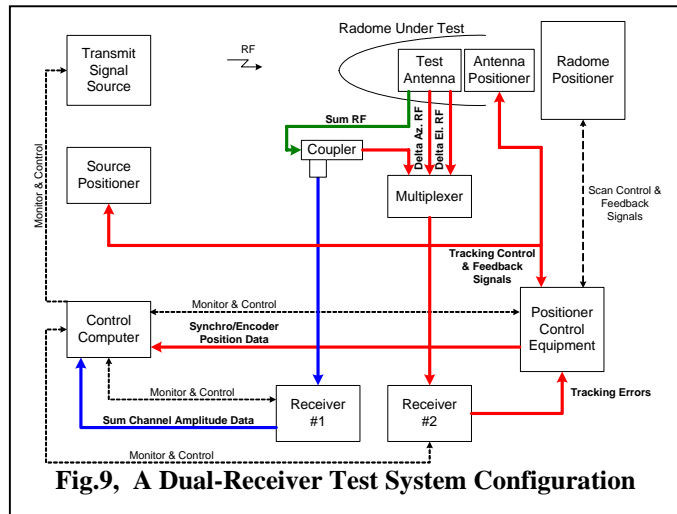

Fig.9, A Dual-Receiver Test System Configuration

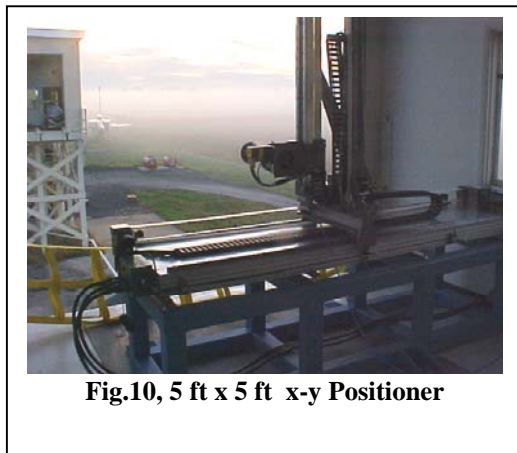

Fig.10, 5 ft x 5 ft x-y Positioner

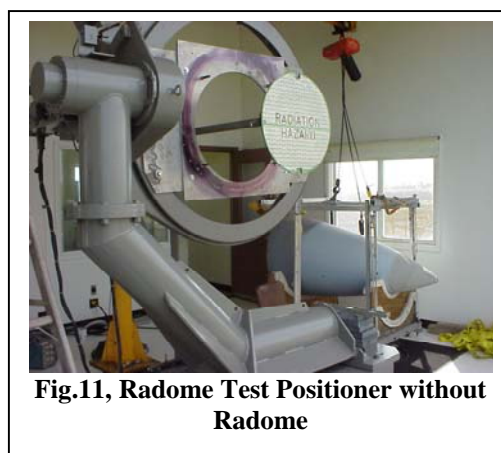

Fig.11, Radome Test Positioner without Radome

The system illustrated in Figure 9 can be configured to track with either an X-Y scanner or the antenna gimbal. A null seeker positioner (i.e. a precision servo-controlled x-y scanner as the source positioner) is

normally employed to translate continuously the transmit antenna to the apparent electrical boresight direction of the antenna-radome combination [1]. A dual-receiver radome measurement system of this configuration is currently operational at Boeing's Avionic Laboratory Antenna Range located in St. Charles, MO.

A 5x5 ft. x-y scanner operates as the null seeker positioner. Figure 10 is a photograph of the installed x-y positioner, viewed looking from the transmit site toward the receiving radome test site. Figure 11 is a photograph of the installed radome positioner with an independently mounted test antenna and the radome not mounted.

6. Compact Range for Radome Testing

The source of plane-wave illumination for testing radomes is not required to be a far-field transmitter; quite often a compact range is used. A compact range is a device for producing a localized plane wave within a confined space. It operates by collimating a point source of radiation with a large paraboloidal reflector. MI Technologies has recently completed delivery of a compact range - based radome test range. It was built under contract to Chelton Advanced Composites in Linköping, Sweden [4].

The form of the test positioner is that of Figure 8. A photograph of the test positioner as installed in the compact range chamber with complete absorber covering is shown in Figure 12. The following paragraphs from Reference [4] describe the system, which is illustrated in Figure 13.

“The compact test range was designed for the frequency range 8—18GHz (X- and Ku-band), and for a quiet zone with the size; 1.83m (length) x 1.83m (width) x 1.50m (high). In the quiet zone, the amplitude taper is < 1dB, the amplitude ripple is < ± 0.3 dB, and the phase error is < $\pm 3^\circ$. Furthermore, the cross polarization is essentially < -25dB in the quiet zone, and fulfill < -30dB over a cylinder with diameter 1m.”

“The position control system is an MI Technologies standard system, and consists of two MI-4193 position controllers complete with PAUs, see Figure 13. The RF system is also a system from MI Technologies, and consists of two MI 3102 RF sources, , and an MI-1797 receiver, together with an LO/IF distribution unit. There are four measurement channels provided with a 4-channel-switch which is mounted on the radome antenna post. The positioner and the RF system are controlled by an automatic measurements system MI-2097 on a workstation PC.”

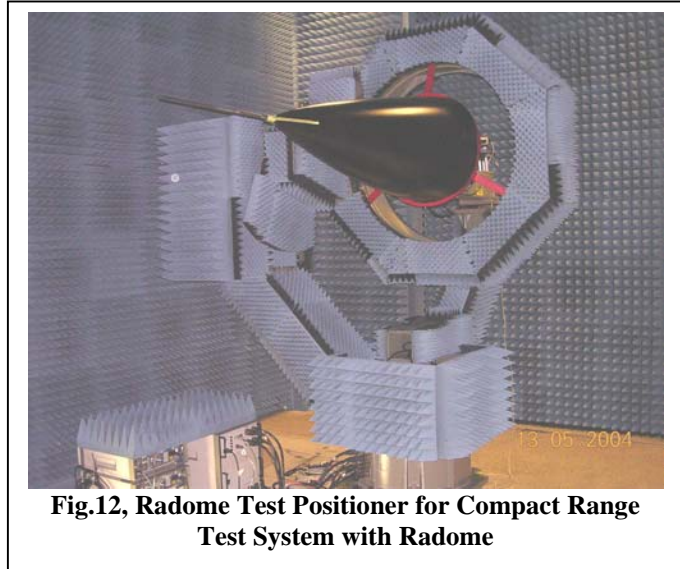

Fig.12, Radome Test Positioner for Compact Range Test System with Radome

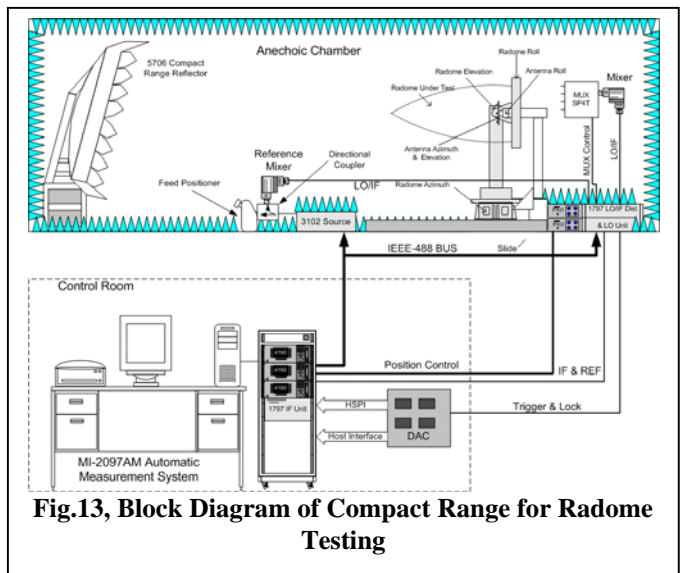

Fig.13, Block Diagram of Compact Range for Radome Testing

7. Radome Testing with Near-Field Scanning Ranges

A continuing trend for antenna measurement technology has been the move to near-field scanning techniques. The advent of ever faster digital computer speeds and the reduced size of near-field ranges compared to outdoor ranges and large chambers have driven this change. In recent years, there have been several near-field scanning ranges built to assess radome performance as well. An example of a near-field range for radome measurements is one located at Chelton Radomes, Ltd at Stevenage, U.K. [6]. A photograph is shown in Figure 14. The range is housed in a large rectangular chamber that is 10 m by 10 m by 7 m. It operates over the band 1.0 to 18 GHz. Key specifications are an elevation pointing accuracy of 0.01 mR and a transmission loss measurement accuracy of ± 0.1 dB. Chelton Composites also operate a 2.5 m near-field scanning range that includes both planar NF and cylindrical NF capability. The smaller facility is described in detail in [6].

Near-field scanning is recognized for the excellent radiation pattern accuracy achievable. This derives from several factors: the completeness of the theoretical basis, the controlled environmental conditions, the instrument stability available with digital electronics, and the control of range reflections with anechoic radar absorbing material. Since radome measurements entail ascertaining the difference between two radiation patterns, it is understandable that near-field scanning measurements yield accurate measures of radome performance as well. However, no closed loop tracking function is available.

Another example of a near-field scanning range that is used to assess radiation patterns of radome-covered antennas is a spherical NF range operated by BAE Systems Insyte, Isle of Wight, UK. A photograph of this range with a utility radar antenna is shown in Figure 15.

This range, commissioned in 2003, was built by MI Technologies. The azimuth rotator is a part of the deliverable radar rather than being a permanent fixture of the range. The arch spans 135 degrees measured from the zenith; the range yields 360 degrees of coverage in azimuth. Measurement of the Sampson radar antenna is one of the key applications of this range. The Sampson ship-borne radar, is covered by a spherical radome housing; this spherical arch can be used to assess the radiation patterns of the radar antenna with its radome in place. A photo is shown in Figure 16 illustrating the measurement.



Fig.14, A 6 m Cylindrical NF Range
Courtesy C.McCartney, Chelton Composites



Fig.15, A Spherical NF Arch with Utility Radar From BAE Systems Insyte, Isle of Wight, UK



Fig.16, Spherical NF Arch with Sampson Radome From BAE Systems Insyte, Isle of Wight, UK

8. Conclusions

We have reviewed the basics of modern radome measurements and shown how three types of measurement approaches have been implemented in the recent past – far-field ranges, compact ranges and near-field scanning ranges. At the heart of every implementation is an automatic system that enables data acquisition, data correction, NF to FF data transformation, far-field data reduction, and radome data display.

9. References

- [1] J.S. Hollis, T.J. Lyon, and L. Clayton, Editors, *Microwave Antenna Measurements*, Chapter 12, Scientific-Atlanta, Inc., Atlanta, GA, 1985.
- [2] Prepared by SC-173, *Minimum Operational Performance Standards for Nose-Mounted Radomes*, RTCA, Inc. 1140 Connecticut Ave. NW, Ste.1020, Washington, D.C.
- [3] R. Luna, T. Thomas, D. Darsey, J. Vortmeier, A Dual Receiver Method for Simultaneous Measurement of Radome Transmission Efficiency and Beam Deflection, *AMTA 2003 Symposium Digest*, pp. 579-584, 2003.
- [4] B.Widenburg, "Advanced Compact Range for Both Radome and Antenna Measurement," 11th European Structures Conference, 12-16 September 2005, Torino, Italy. Copy available at web site http://www.chelton.se/userfiles/Advanced_compact_test_range.pdf.
- [5] J. Fordham and M. Scott, "Antenna Pattern Comparison Between an Outdoor Cylindrical Near-Field Test Facility and an Indoor Spherical Near-Field Test Facility," *IEEE AP-S Magazine* Vol. 46, pp. 146-150, June, 2004.
- [6] W.C. Dixon, D.J. Van Rensburg, "Evaluation of Radome Performance From Cylindrical Near-Field Measurements," *AMTA 2003 Symposium Digest*, pp. 476-481, 2003.