

Networked Acquisition Controller Reduces Antenna Test System Overhead

by Derek Skousen and Marion Baggett, MI Technologies

Antenna characterization requires making large quantities of RF measurements across a known spatial position. In practice, this involves coordinated positioning equipment, test instruments, and software processing. The overhead of networking, handshaking, sequencing, triggering, and data management between these devices is often the limiting factor in total system performance. Antenna test engineers are often frustrated by slow system performance, despite using the fastest equipment available.

MI Technologies has addressed the overhead issue with the introduction of the MI-788 Networked Acquisition Controller, which fluently manages the data flow and triggering requirements of complex antenna measurement systems.

Antennas are possibly the most diverse single component type in all of electrical engineering, with almost no end to the range of sizes, shapes, and structures being devised. Yet the basic purpose of each remains the same: to serve as a transducer of the system's radiated energy to and from free space.

Because antenna measurement systems are designed to make a variety of accurate free space measurements, they can also be applied to any application where the interaction with a radiated field is of interest. Examples include radome, radar cross section (RCS) and microwave materials measurements.

Antenna System Elements

Most antenna test facilities are built with a few common system elements:

Positioning System and Chamber: Mechanically provides a known position in free space where the field measurement is made. Position accuracy and repeatability are critical to collect acceptable measurement data. Where possible, measurements are performed in an anechoic chamber to reduce contamination from external signals.



Figure 1: MI-788 Networked Acquisition Controller

Position Controller: Interfaces the mechanical positioning system to the measurement system. It directly drives the various motion axes and returns a variety of position feedback and timing signals.

Source: Provides the transmit side of the free-space system. Often mixers, multipliers and power amplifiers are added to the source system to appropriately condition the signal. Fast frequency switching is often desired to quickly gather multiple frequency responses as the antenna moves through a defined space.

Receiver: Measures the response of the antenna to the transmitted signal. Again, many external signal conditioning elements such as mixers, amplifiers and

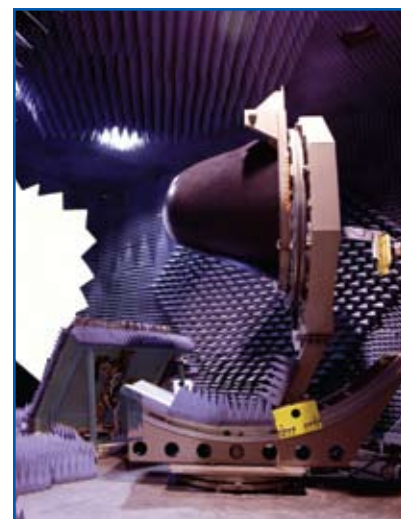

Figure 2: Radome testing in compact range system

multiplexers are distributed in the range to improve reception. A high dynamic range and fast measurement time are important in antenna measurement receiver systems to accurately measure wide peaks and nulls in the antenna at many positions over multiple frequencies. Because most antenna measurements are essentially a two-port CW measurement, a vector network analyzer (VNA) can be used for both source and receiver elements in many test systems.

Software: At the heart of any modern antenna measurement system is a sophisticated software platform to acquire, control and coordinate all of the above equipment sets. An antenna system scan can return very large quantities of data that must be gathered, processed, analyzed and synthesized as needed. Additional switching, triggering, buffering and control hardware are usually needed to interface between the asynchronous software running on a PC operating system and the highly coordinated and synchronous measurement systems.

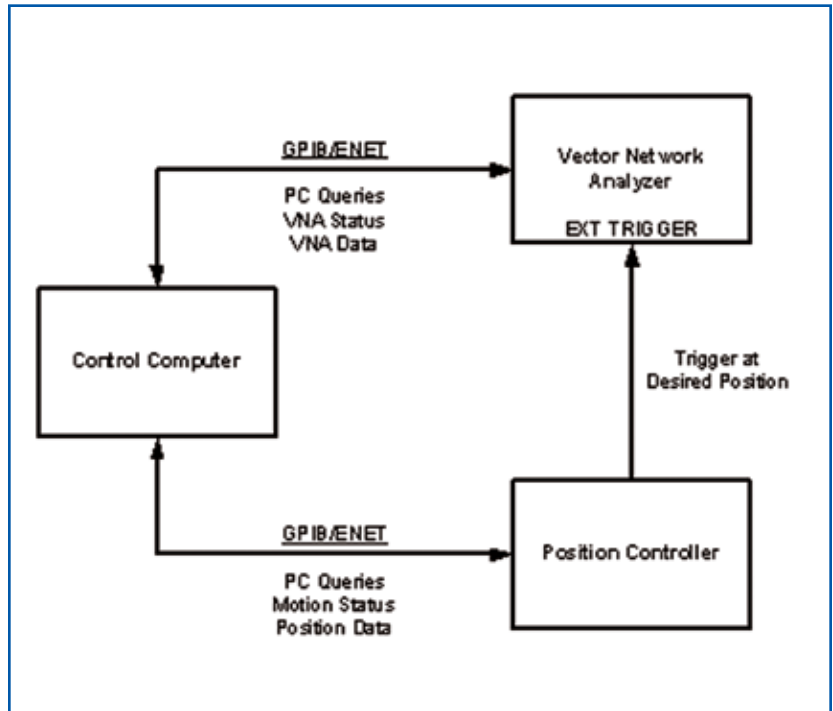

Figure 3: Simple VNA based measurement system

Simple Antenna Measurement System

A simple antenna measurement system is shown in Figure 3. The position controller generates a TTL trigger signal on reaching each desired position in a scan. The network analyzer performs the configured measurement sequence. If the analyzer has the capability to buffer many sets of triggered data, the control computer only has to track position, and then it can periodically extract sets of data from the receiver and merge the two data sets together. However, if the receiver cannot buffer data, the control computer must collect the data before the next trigger arrives from the position controller, or the data will be lost. In this scenario, the software logic in the control computer is generally:

- Poll the position controller for the next desired position
- On recognition of reaching the desired position, read the position from the position controller
- Poll the receiver for measurement complete
- Read the receiver data

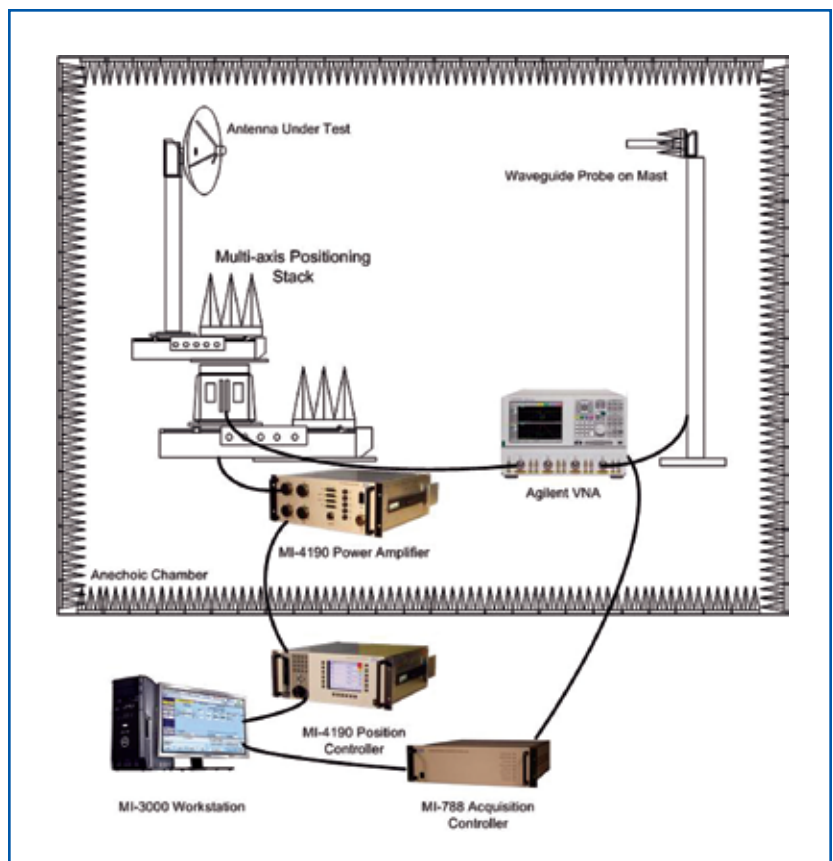

Figure 4: Antenna test system with VNA and MI-788 Networked Acquisition Controller

If the receiver is doing a long and complex measurement, it will dominate system throughput. However, for simple single frequency, single channel measurements, the control computer overhead will dominate. Experiments performed with a non-buffering vector network analyzer as a receiver, a position controller and a Windows based PC show that this scenario can yield as few as 10 position measurement sets per second. The VNA can be configured to collect measurements on up to 20 to 30 frequencies before the system throughput is impacted due to VNA operation. This shows a high level of computer overhead.

Adding Complexity

As the measurement system becomes more complex, straightforward control computer operations become more difficult. For many antenna measurement systems, an external signal source may be required on the transmit side. The usual method for fast frequency switching in this scenario is to cross connect the source external trigger and frequency locked signals with the receiver measurement/sweep done and external trigger lines. This allows the receiver and source to handshake quickly, but the external trigger signal for the receiver is no longer available for the position controller trigger. This adds more overhead at the control computer level. Some new VNAs, such as the Agilent PNA-X, provide additional trigger signal lines to overcome this problem. When an external LO source is also required, such as for a remote mixing configuration, the traditional method is to daisy chain the two sources and the receiver trigger signals. This results in a frequency change requiring the tuning delays for both sources in series, doubling frequency switching time for the system.

Modern antennas may require many signal channels or may include a beam steering computer, which requires an interface, most likely with a handshake to hold off the measurements until the beam steering computer has completed its change. A possible solution to these issues is to add DIO interfaces to the control computer, but this adds even more burden on the control software to manage these extra activities.

The MI-788 Networked Acquisition Controller

To address these issues, the MI-788 Networked Acquisition Controller has been developed to provide control of devices outside the receiver and to remove

any real time burden from the control computer. The major features of the MI-788 are:

- All trigger lines used by the position controller, the receiver and any external sources are managed by a Field Programmable Gate Array (FPGA). Latency for any trigger recognition or generation of a trigger is less than 10 microseconds.
- A second FPGA manages the high speed parallel interface for position data.
- The MI-788 processor buffers large blocks of data for extraction by the control computer asynchronously to the real time measurement cycle. This removes real-time burdens from the control computer.
- The MI-788 can manage up to 16 channels of data using the MI-3320 family of multiplexers.
- A 16 bit RS-422 interface manages a beam steering computer or additional switches. A two wire handshake is included so that the beam steering computer can be alerted to a new control pattern and the next measurement can be held off until the beam steering computer has completed its operations.
- Trigger handshake lines manage frequency switching for an external source and an external LO source when needed.
- Status indicators monitor position triggers, receiver

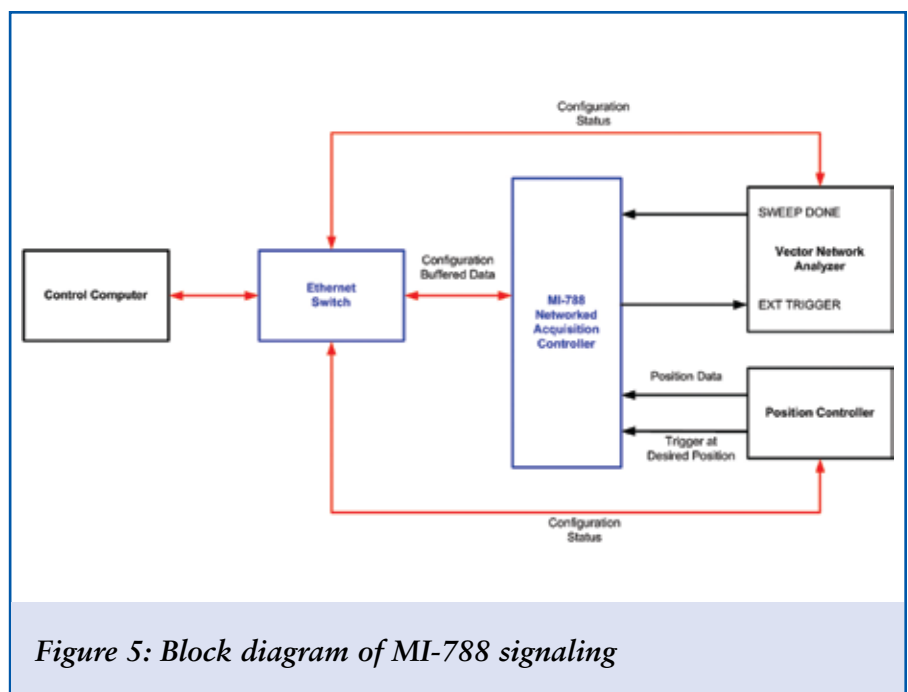

Figure 5: Block diagram of MI-788 signaling

triggers, receiver measurement complete signals, and the external source trigger lines.

The MI-788 in Measurement Systems

Returning to the simple measurement system of **Figure 3**, the same system with an MI-788 included is shown in **Figure 4**, with signaling diagrammed in **Figure 5**. For each position, the trigger from the position controller is recognized by the MI-788 and re-routed to the receiver with the polarity and width desired by the receiver. If position data is desired, the current position is collected at this time. The measurement complete signal from the receiver is then picked up by the MI-788 after the receiver completes its measurement. The timing circuitry notifies the high level processor in the unit that the measurement is complete. If the receiver does not buffer data, the high level processor in the MI-788 extracts the data from the receiver via Ethernet and stores it along with any position data. If the receiver can buffer data internally, the MI-788 counts the position increments and periodically extracts the data from the receiver as well as position data, if required. The control computer can then request buffered data periodically. These large blocks of data can be moved very efficiently over the Ethernet interface.

The simple measurement system of **Figure 3** with a non-buffering VNA could perform around 10 position measurement sets per second with a minimal VNA measurement. In contrast, the system of **Figure 4** with the MI-788 has been tested in the same scenario with over 100 position measurement sets per second, increasing system throughput by an order of magnitude.

When external multiplexers and/or a beam steering interface are included on each position trigger

signal, the FPGA timing circuitry sets the proper multiplexer setting and/or beam state before triggering the receiver. On each receiver measurement complete, the next external channel and/or beam state is set and the receiver triggered again. If the receiver can buffer data, the MI-788 adds less than 10 microseconds of overhead for each channel change or beam state. If the receiver cannot buffer data, the MI-788 must read the receiver on each channel or beam state, adding less than one millisecond of overhead for switching management, not including the time to read the receiver.

When external sources are used, the MI-788 timing circuitry will cycle the sources through all frequencies in the acquisition set before notifying the high level processor to read the receiver. The high level processor then reads the entire frequency set as a group from the receiver.

Summary

The MI-788 Networked Acquisition Controller has been developed to improve measurement throughput in simple antenna measurement systems using a network analyzer. By reducing PC overhead, an order of magnitude speed improvement in some measurement scenarios with the MI-788. It also provides an integrating and control point for external sources, multiplexers or beam steering computers when using a receiver in an antenna measurement system.

MI TECHNOLOGIES



www.mi-technologies.com

1125 Satellite Blvd, Suite 100
Suwanee, Georgia 30024-4629 USA
sales@mi-technologies.com

Phone: 1.678.475.8300
Fax: 1.678.542.2601