



MI-4190 Family

Of

Position Controllers

System Configurations And System Options

This document contains specifications and information that are subject to change without notice. This guide is intended to assist buyers in the selection of product configurations that can provide the best position management solution required for their application needs.

MI Technologies
1125 Satellite Blvd.
Suite 100
Suwanee, Georgia 30024-4629
www.mi-technologies.com

800-854-3660
+1-678-475-8300

Note

The MI-4190 family of position control products are computer based, technically complex, instruments. Specific performance attributes will vary depending on the customer hardware configuration. Care should be taken to understand the relationship between the positioning devices and these position controllers.

MI Technologies' applications engineers can assist the user in final selection of the required equipment. This guide is intended to present a basic overview of the products and selected options.

Detailed technical questions should be referred to our factory application engineer at the Sales or Service numbers shown below.

MI Technologies

1125 Satellite Blvd.

Suite 100

Suwanee, Georgia 30024-4629

www.mi-technologies.com

800-854-3660

+1-678-475-8300

Introduction

This configuration guide presents an overview of the MI-4190 Position Controller family of products. It is intended to provide general information about this product family and to assist in identifying product configurations and options that are available for position management solutions. This configuration guide will continue to evolve and be updated frequently as we learn more about customer information needs.

This document is not an equipment specification and we do not guarantee the accuracy of all information contained herein. Specifications and product availability are subject to change without notice.

Product Summary

The MI-4190 Position Controller product family consists of the following :

- MI-4191-FP Single Axis – To 1 horsepower motor drive capability. Unit is a self contained integrated package which includes the motor power amplifier.
- MI-4192-FP Four Axis Sequential Controller and Power Amplifier – To 1 horsepower drive capacity. Configured as 2 units, the Power Amplifier may be located up to 150 feet from the Control Unit.
- MI-4193-FP Four Axis Controller and Power Amplifier – To 1 horse power drive capacity per axis. All axes have independent motor amplifiers. Configured as 2 units, the Power Amplifier may be located up to 150 feet from the Control Unit.
- MI-4193S2-FP The “S” versions of this controller are unique versions of the basic MI-4193 specifically configured to drive MI Technologies Planar Scanner products that utilize linear drive motors.
- MI-4193S4-FP
- MI-4194 This model number series is provided to identify a custom solution approach. Customers who require a unique application custom solution to their motion management requirements and are able to utilize various components of MI-4190 products fall into this class. These custom solutions require the contribution of engineering resources that will be quoted separately in a proposal format. MI Technologies welcomes the opportunity to assist customers in identifying solutions to their complex motion control requirements.
- MI-4195BR-FP Four Axis Sequential Controller and Power Amplifier – To 5 horse power drive capacity. Configured as 2 units, the Power Amplifier may be located up to 150 feet from the Control Unit. This configuration is structurally similar to the MI-4192-FP except for the ability to drive 5 horsepower motors.
- And
MI-4195BL-FP

General information that customers should be made aware of:

1. Electronic interfaces to MI-4190 Products include IEEE 488, Serial, and Ethernet. The command syntax utilized for these hardware interfaces was developed by MI Technologies specifically for this product and does not completely conform to the specifics of the IEEE 488 or other standards. This means that not all of the command syntax capabilities of the standards are used, nor are all those that are used processed in the exact manner that the standard may describe. The complete control syntax is contained in the product manual and can also be supplied as a separate document for review by potential customers.
2. Each application of this product will require a customer specific setup to accommodate the characteristics of the positioner to be controlled. Some understanding of motor control techniques will be helpful. Detail questions regarding specifications and performance characteristics should be referred to the factory. Assistance can be provided by MI Technologies Support Service organization.
3. The MI-4190 Products are computer based units and include digital processing for positioning and control. All analog feedback devices, such as synchros, are converted to a digital format. Due to this conversion, some trigger modes will have rounding on the least significant bit that can result in offsets in the exact position that a trigger will occur. When using this unit for trigger outputs, care should be given to select an appropriate trigger mode and to select record increments that will provide the smallest accumulated rounding offsets. This is most important for very small record increments. The operator manual provides detail information on this topic.
4. There are a wide variety of positioners that are candidates for use with the position controllers described in this guideline. Internal wiring as well as interface connections will vary from positioner to positioner. The position controllers described in this guideline are designed for interfacing to current production positioners manufactured by MI Technologies. Fielded positioners may require adapter cables, conversion boxes, or possibly rewiring depending on the time of original manufacture as well as potential modifications made after delivery.
5. Safety is a critical consideration for any system that uses the MI-4190. Appropriate safety measures are a function of the type of mechanical system being controlled, the environment in which the system is used, and regulatory requirements. Several safety features are included in the MI-4190 to facilitate implementation of appropriate safety measures, including software limits, primary and secondary limit switch inputs, and an Emergency Stop interface. A proper MI-4190 configuration will make use of these and any other required features to assure that the risk of harm to personnel and equipment is minimized. See the section on Safety Considerations for further information.

MI-4190 Product Family

MI-4191-FP Position Controller Package

Single Axis – To 1 Horse Power Version with Functional Front Panel

Includes MI-4191F, MI-4190-15, MI-4190-R (Rack Slides), MI-4190-OM1 (Operator Manual)

The base configuration of the MI-4191-FP controller includes operation with tachometer and synchro position feedback. The controller can accommodate incremental encoder position feedback under certain conditions but requires consultation with factory to confirm compatibility and application. Encoder operation is a factory setup and once delivered cannot operate in synchro mode unless returned to factory for configuration setup change.

The MI-4191-FP is designed to support brush or brushless motor control. The predominant motor types in positioners are brush type and therefore the controller default hardware configuration supports only that mode. Should a customer have a requirement for the brushless mode, then the MI-4191-FP must be configured at the factory for that type of operation. To switch modes, the unit must be returned to factory for reconfiguration.

The controller is delivered with rack slides such that the unit can be installed in the customer's rack if desired.

If outdoor operation is required, the customer will be required to provide an appropriate enclosure to protect the unit. MI Technologies can quote an outdoor enclosure but requires specific information from the customer regarding general environmental conditions that may be encountered at their location as well as any restrictions relating to local codes.

Figure 1 illustrates the MI-4191-FP with some of the options available. The standard MI-4191-FP includes both IEEE-488 and Ethernet interfaces.

MI-4190 Position Controllers

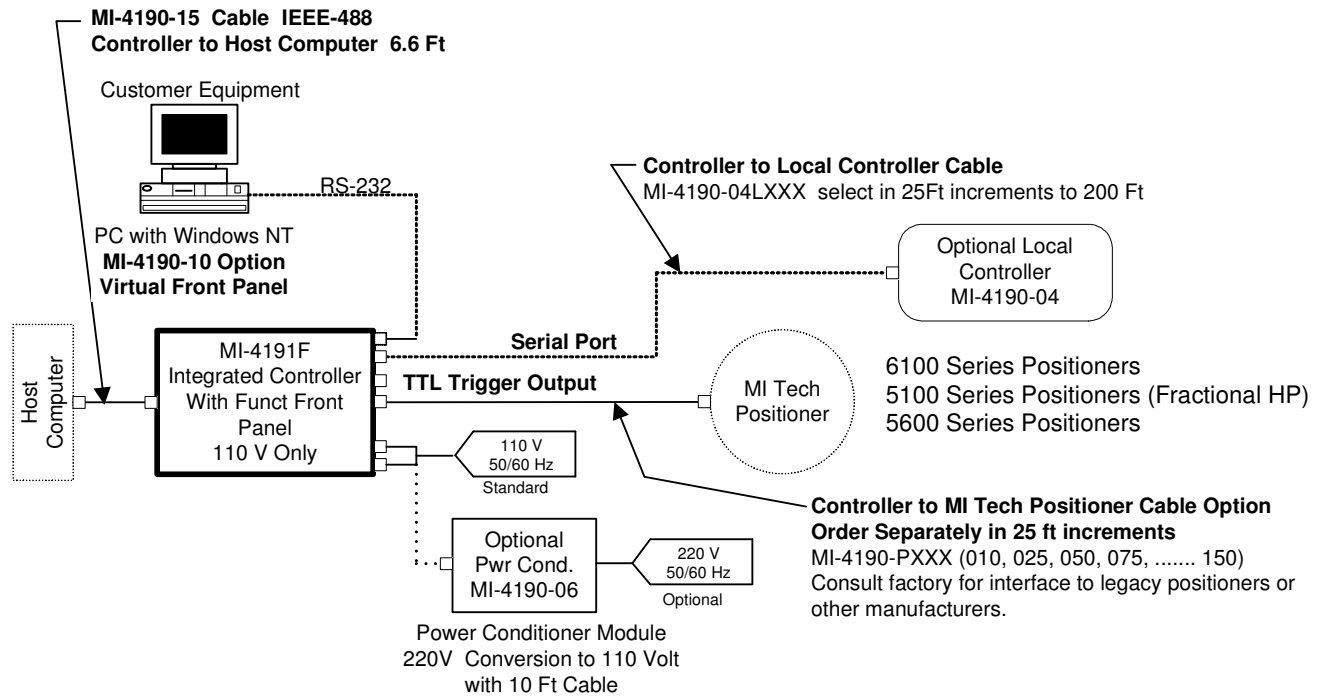

Figure 1 MI-4191-FP and Options

Options to Consider with this Product.

MI-4190-03 Indoor Cabinet Assembly (21 inch high)

This is the standard indoor cabinet for MI-4190 units and can accommodate up to 3 electronic units.

MI-4190-PXXX PAU to Positioner Cable

- In the case of the MI-4191-FP, this is the Controller to Positioner Cable as the Motor Amplifier is part of the Controller.
- Only one cable is required as only one axis can be controlled.
- The MI-4190-09 Junction Box is not recommended for use with this unit.

*This is a required cable that must be selected for connection between the Controller and the positioner). This cable is configured for new positioners which have MI-4190 compatible connector interfaces. For connections to positioners that are already fielded, consult with the factory.
The XXX in the model number relates to the available cable lengths to 150 feet in 25 foot length increments, i.e. 025 is 25 ft, 075 is 75 ft ... 150 is 150 ft.*

MI-4190-04 Hand Held Local Control Unit

This unit provides the operator with the ability to operate the controller from a location near the positioner. It provides most of the functions of

MI-4190 Position Controllers

the Controller front panel. The unit is water resistant, not water proof, and must be stored in a protected location. Connecting cable ordered separately.

MI-4190-04LXXX Controller to Hand Held Local Control Unit Cable

This cable must be ordered with the MI-4190-04, Local Hand Held Unit option. The XXX in the model number relates to the available cable lengths to 200 feet in 25 foot length increments, i.e. 025 is 25 ft, 075 is 75 ft ... 150 is 150 ft.

MI-4190-07 Outdoor PAU Enclosure

Enclosure for the protection of the equipment in an outdoor environment. Enclosures should be the responsibility of the customer. Exact enclosure selection, if purchased from MI Technologies, will require specific environmental information from the customer related to local environmental conditions as well as mounting requirements.

MI-4190-06 Power Conditioner Module

Consult factory for power conditioner use with MI-4193 Models.

This unit is required in European and other applications where 220 volt supplies are present. The Servo Amplifiers used in the MI-4190 products require 110 volt service for proper operation. This is a required option in the case of 220 volt services.

MI-4190-10 Virtual Front Panel

Requires Windows NT operating software on host PC.

Software package that can be installed in a standard PC Computer and be used to operate the MI-4190 Controllers through the Serial Port. This feature can provide ability to locate the controller in a more remote location, yet maintain local control.

MI-4192-FP Position Controller Package

*Multi Axis – To 1 Horse Power Version, with Functional Front Panel
Includes MI-4192F (Controller), MI-4192-11 (Power Amplifier Unit), MI-4190-15 (IEEE Cable),
MI-4190-R (Rack Slides), MI-4190-OM2 (Operator Manual)*

The base configuration of the MI-4192-FP controller includes operation with tachometer and synchro position feedback. The controller can accommodate incremental encoder position feedback under certain conditions but requires consultation with factory to confirm compatibility and application. Incremental encoder operation is not usually recommended with the MI-4192-FP due to axis switching. Each time an axis is switched, the next axis may have to be indexed to insure accurate position control when using incremental encoders.

The basic MI-4192-FP package can accommodate up to 4 axes of control with drive motors to 1 horsepower. The MI-4192F Control unit has 2 PAU interface ports which provide the option to add an additional PAU, increasing the number of axes controllable to 8.

The Controller and PAU are delivered with rack slides such that the units can be installed in the customer's rack, or select from available cabinets, racks and enclosures from MI Technologies.

The MI-4192-FP is designed to support brush or brushless motor control. The predominant motor type in positioners is brush type motors, and therefore the controller default hardware configuration supports only that mode. Should a customer have a requirement for the brushless mode, then the MI-4192-FP must be configured at the factory for that type of operation. To switch modes in a fielded unit, the unit must be returned to factory for reconfiguration.

If outdoor operation is required, the customer will be required to provide an appropriate enclosure to protect the equipment. MI Technologies can quote an outdoor enclosure but requires specific information from the customer regarding general environmental conditions that may be encountered at their location.

The MI-4190 products are configured to interface with current production MI Technologies positioners. Older positioners in the field may require adapter cables, a conversion junction box, or positioner rewiring to accommodate the interface to the MI-4190 products.

Figure 2 illustrates the basic MI-4192-FP product configuration connected to current production positioner with several other common options. The standard MI-4192-FP includes both IEEE-488 and Ethernet interfaces.

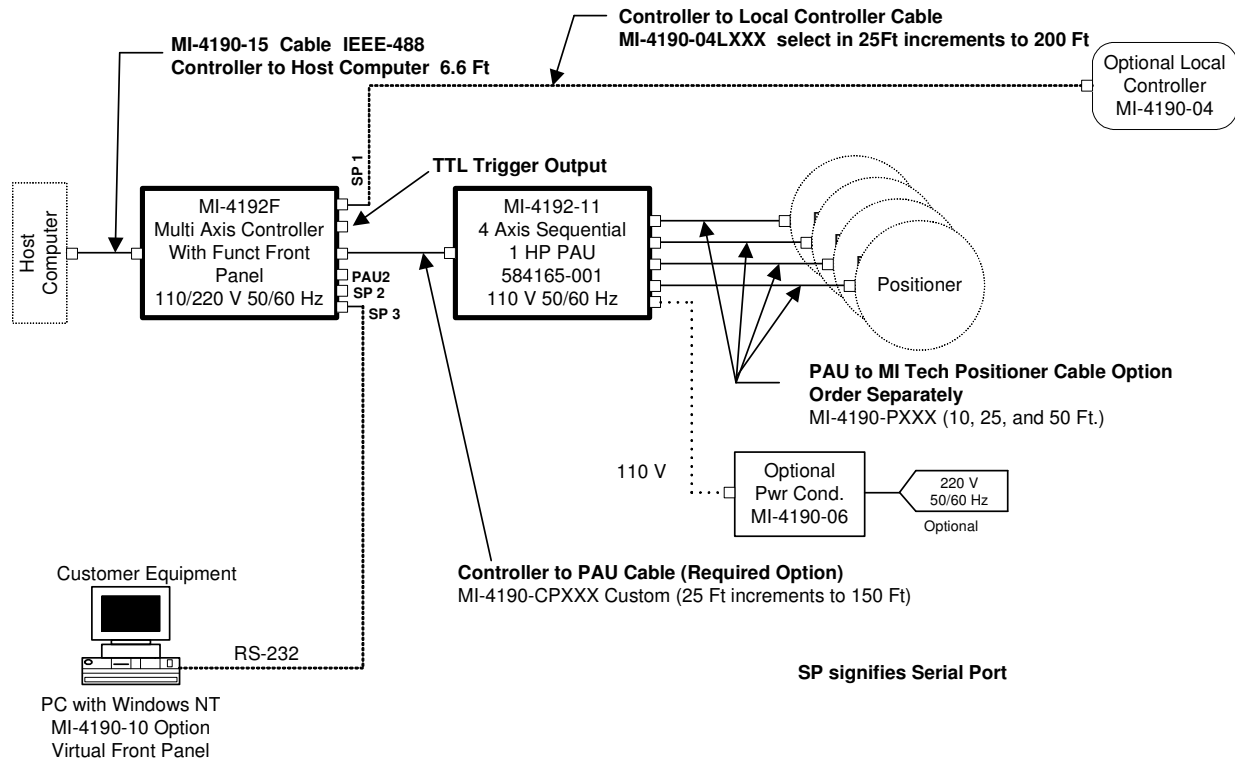

Figure 2 MI-4192-FP and Options

Other Options to Consider with this Product.

MI-4190-03 Indoor Cabinet Assembly (21 inch high)

This is the standard indoor cabinet for the MI-4190 units and can accommodate up to 3 electronic units.

MI-4190-09 Junction Box – MI-4192-11 PAU to MI-4139 Cable Interface

This option provides the customer with the capability to replace an MI-4139 configuration with the MI-4192-FP and utilize the existing cable set that is currently interfaced to the positioner. The junction box mounts below the PAU and has pigtail cables that plug into the PAU. The output connections are the same as the MI-4139.

See Figure 3

MI-4190 Position Controllers

MI-4190-10 Virtual Front Panel

Requires Windows NT operating software on host PC.

Software package that can be installed in a standard PC Computer and be used to operate the MI-4190 Controllers through the Serial Port. This feature can provide ability to locate the controller in a more remote location, yet maintain local control.

MI-4192-11 Power Amp Unit, 4 Axis Sequential

This option will provide for an additional 4 Axes of control to the controller. If this option is selected, the appropriate cables as shown in figure 2 for the basic PAU will be required. This unit will interface to the PAU2 connector port on the Controller.

MI-4190-06 Power Conditioner Module

Consult factory for power conditioner use with MI-4193 Models.

This unit is required in European and other applications where 220 volt supplies are present. The Power Amplifiers used in the MI-4190 products require 110 volt service for proper operation. This is a required option in the case of 220 volt services.

MI-4190-CPXXX Controller to PAU Cable

This is a required cable that must be selected for connection between the Control Unit and the PAU. The XXX in the model number relates to the available cable lengths to 150 feet in 25 foot length increments, i.e. 025 is 25 ft, 075 is 75 ft ... 150 is 150 ft.

MI-4190-PXXX PAU to Positioner Cable

This is a required cable that must be selected for connection between the PAU and the positioner(s). Up to 4 cables may be required. This cable is configured for new positioners which have MI-4190 compatible connector interfaces. For connections to positioners that are already fielded, consult with the factory. The MI-4190-09 Junction Box may be a suitable selection for interfacing to legacy positioners currently interfaced to the MI-4139 Controller. The XXX in the model number relates to the available cable lengths to 150 feet in 25 foot length increments, i.e. 025 is 25 ft, 075 is 75 ft ... 150 is 150 ft.

MI-4190-04 Hand Held Local Control Unit

This unit provides the operator with the ability to operate the controller from a location near the positioner. It provides most of the functions of the Controller front panel. The unit is water resistant, not water proof, and must be stored in a protected location. Connecting cable ordered separately.

MI-4190 Position Controllers

MI-4190-04LXXX Controller to Hand Held Local Control Unit Cable

This cable must be ordered with the MI-4190-04, Local Hand Held Unit option. The XXX in the model number relates to the available cable lengths to 200 feet in 25 foot length increments, i.e. 025 is 25 ft, 075 is 75 ft ... 150 is 150 ft.

MI-4190-07 Outdoor PAU Enclosure

Enclosure for the protection of the equipment in an outdoor environment. Enclosures should be the responsibility of the customer. Exact enclosure selection, if purchased from MI Technologies, will require specific environmental information from the customer related to local environmental conditions as well as mounting requirements.

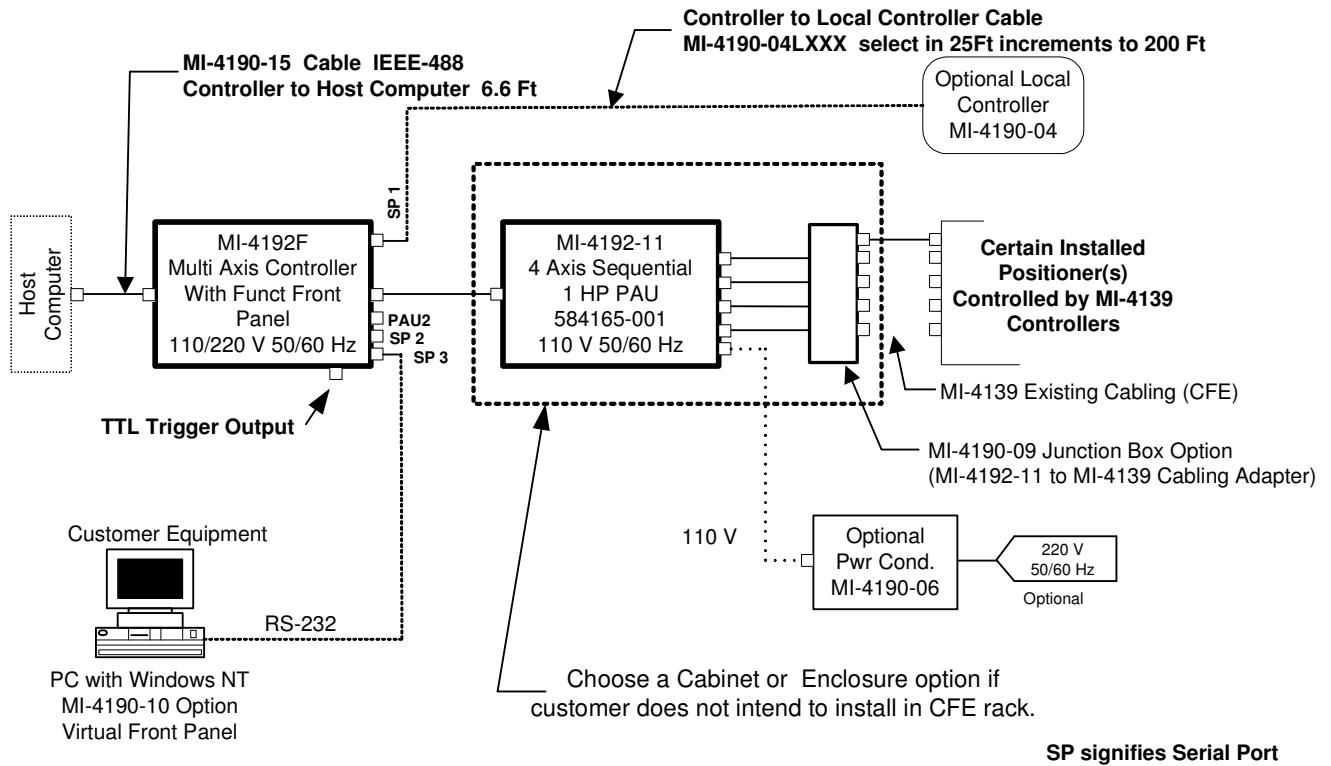

Figure 3

MI-4192-FP Configuration with Outdoor enclosure and Junction Box

MI-4193-FP Position Controller Package

*Multi Axis – To 1 Horse Power Version, with Functional Front Panel
Includes MI-4193F (Controller), MI-4193-18 (Power Amplifier Unit), MI-4190-15 (IEEE Cable),
MI-4190-R (Rack Slides), MI-4190-OM3 (Operator Manual)*

The base configuration of the MI-4193-FP position controller includes operation with tachometer and synchro position feedback. The controller can accommodate incremental encoder position feedback under certain conditions but requires consultation with factory to confirm compatibility and application. With all axes being monitored on this configuration, incremental encoder operation may be a good selection.

The basic MI-4193-FP package can accommodate up to 4 axes of control with drive motors to 1 horsepower. The MI-4193 Control Unit has 4 PAU interface ports with one port required for each axis being operated. Each port may be used to support an MI-4192-11 PAU or an MI-4195-BR-12, providing up to 16 axes of operation.

The MI-4193-FP is designed to support positioners with brush or brushless motors. The predominant style of motors in positioners are brush type and therefore the controller default hardware configuration supports only that mode. Should a customer have a requirement for the brushless mode, then the MI-4193-FP must be configured at the factory for that type of operation. To switch modes, the unit must be returned to factory for reconfiguration.

The basic MI-4193-FP can be used for controlling some models of the MI Technologies' MI-6900 Planar Scanners that are equipped with rotary to linear drive systems for the primary X and Y axes. Two additional motorized axes, typically motorized Z translation and motorized Roll, can be driven from the other 2 ports on the PAU. See the MI-6900 product descriptions for more details on the various models.

The standard MI-4193-FP includes both IEEE-488 and Ethernet interfaces.

MI-4190 Position Controllers

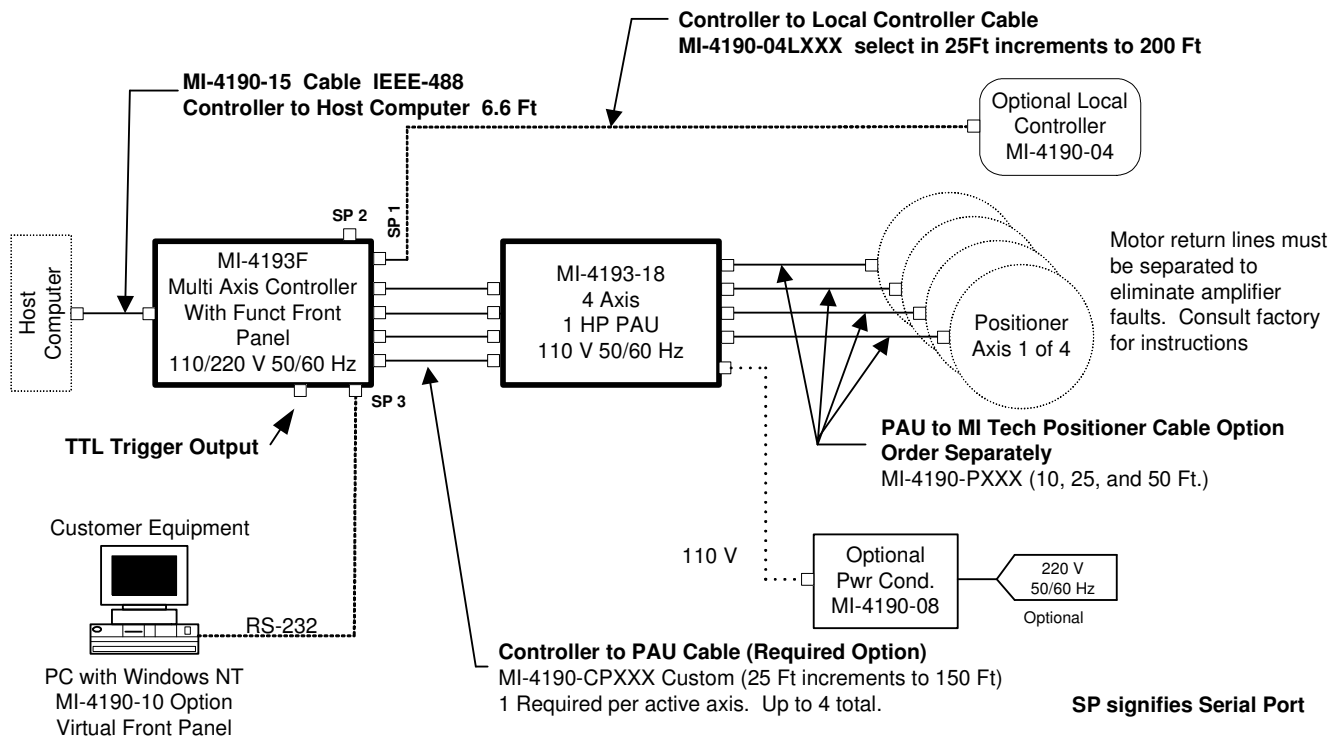

Figure 4 MI-4193-FP Position Controller

Other Options to Consider with the MI-4193 Product.

MI-4190-03 Indoor Cabinet Assembly (21 inch high)

This is the standard indoor cabinet for the MI-4190 units and can accommodate up to 3 electronic units.

MI-4190-06 Power Conditioner Module

Consult factory for power conditioner use with MI-4193 Models.

This unit is required in European and other applications where 220 volt supplies are present. The Servo Amplifiers used in the MI-4190 products require 110 volt service for proper operation. This is a required option in the case of 220 volt services.

MI-4190-09 Junction Box – MI-4192-11 PAU to MI-4139 Cable Interface

This option provides the customer with the capability to replace an MI-4139 configuration with the MI-4192-11 PAU and utilize the existing cable set that is currently interfaced to the positioner. See Figure 3 for configuration. In the case of using this option with the MI-4193F Controller, one of the Axes must be allocated to an MI-4192-11 PAU as the interface to this Junction Box. The junction box mounts below

MI-4190 Position Controllers

the PAU and has pigtail cables that plug into the PAU. The output connections are the same as the MI-4139. The junction box will not interface to any other PAU than the MI-4190-11.

MI-4190-10 Virtual Front Panel

Requires Windows NT operating software on host PC.

Software package that can be installed in a standard PC Computer and be used to operate the MI-4190 Controllers through the Serial Port. This feature can provide ability to locate the controller in a more remote location, yet maintain local control.

MI-4190-CPXXX Controller to PAU Cable

This is a required cable that must be selected for connection between the Control Unit and the PAU. The XXX in the model number relates to the available cable lengths to 150 feet in 25 foot length increments, i.e. 025 is 25 ft, 075 is 75 ft ... 150 is 150 ft. The MI-4193 requires that one of these cables be used for each active axis. Up to 4 cables may be required.

MI-4190-PXXX PAU to Positioner Cable

This is a required cable that must be selected for connection between the PAU and the positioner(s). Up to 4 cables may be required. This cable is configured for new positioners which have MI-4190 compatible connector interfaces. For connections to positioners that are already fielded, consult with the factory. The XXX in the model number relates to the available cable lengths to 150 feet in 25 foot length increments, i.e. 025 is 25 ft, 075 is 75 ft ... 150 is 150 ft.

MI-4190-04 Hand Held Local Control Unit

This unit provides the operator with the ability to operate the controller from a location near the positioner. It provides most of the functions of the Controller front panel. The unit is water resistant, not water proof, and must be stored in a protected location. Connecting cable ordered separately.

MI-4190-04LXXX Controller to Hand Held Local Control Unit Cable

This cable must be ordered with the MI-4190-04, Local Hand Held Unit option. The XXX in the model number relates to the available cable lengths to 200 feet in 25 foot length increments, i.e. 025 is 25 ft, 075 is 75 ft ... 150 is 150 ft.

MI-4190-07 Outdoor PAU Enclosure

Enclosure for the protection of the equipment in an outdoor environment. Enclosures should be the responsibility of the customer. Exact



MI-4190 Position Controllers

enclosure selection, if purchased from MI Technologies, will require specific environmental information from the customer related to local environmental conditions as well as mounting requirements.

MI-4190 Position Controllers

MI-4193S2-FP Position Controller Package

Two Axis Planar Scanner Controller for Linear Motor Drive Systems

Multi Axis – To 1 Horse Power Version, with Functional Front Panel

Includes MI-4193S (Controller), MI-4193S2-18 (Power Amplifier Unit), MI-4190-15 (IEEE Cable), MI-4190-R (Rack Slides), MI-4190-OM3 (Operator Manual)

The basic configuration of the MI-4193S2-FP position controller supports operation with linear incremental encoder feedback for the main X and Y axes. The Z and Roll axes are manual in this configuration. This position controller has been designed exclusively for use with MI Technologies planar scanners. Should there be a requirement to interface these controllers to a third party positioner, a through system engineering evaluation would need to be performed to insure compatibility.

The MI-4193S2-FP is used for controlling certain models of MI Technologies' MI-6900 Planar Scanners that are equipped with high performance linear drive systems for the primary X and Y axes. See the MI-6900 product descriptions for more details on the various models. Figure 5 illustrates a typical 2 Axis Planar Scanner configuration.

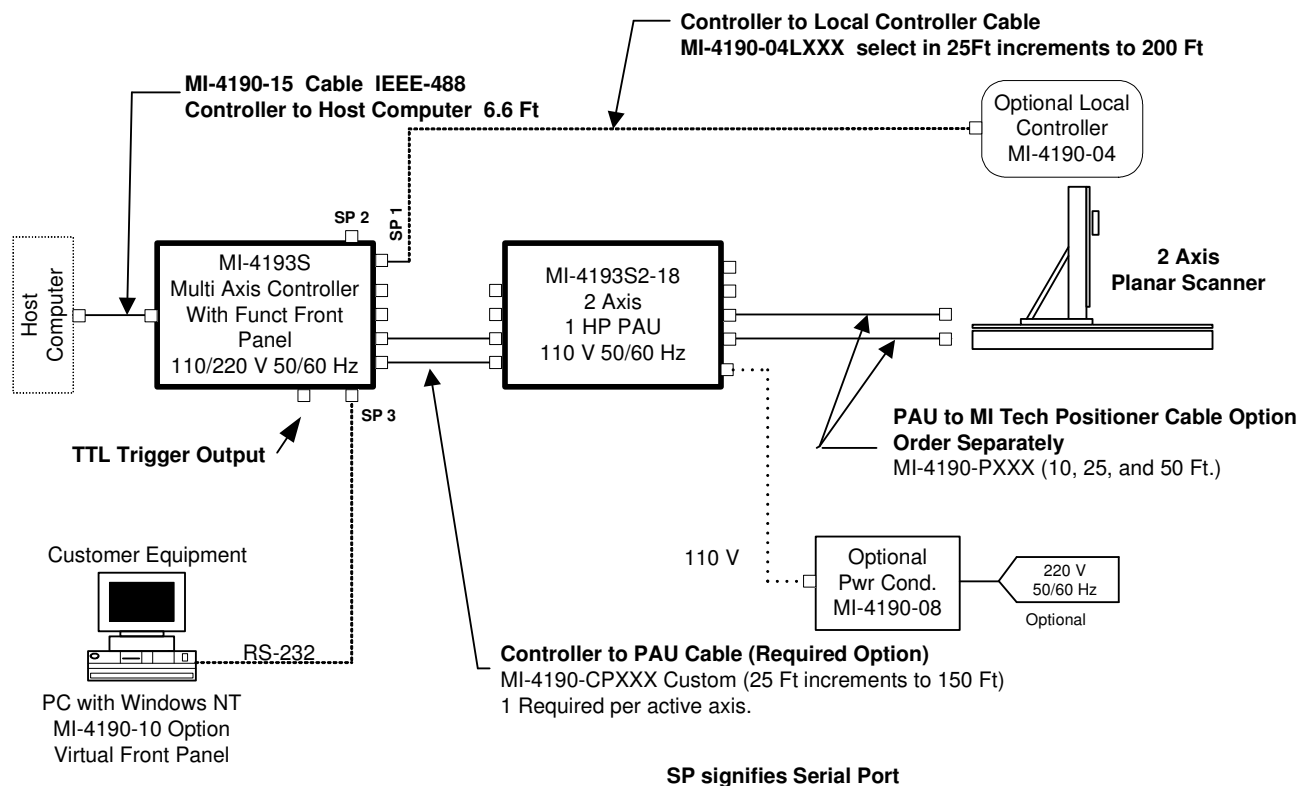

Figure 5 MI-4193S2-FP 2 Axis Planar Scanner Configuration

MI-4190 Position Controllers

MI-4193S4-FP Position Controller Package

Four Axis Planar Scanner Controller for Linear Motor Drive Systems

Simultaneous Multi Axis – To 1 Horse Power Version, with Functional Front Panel
 Includes MI-4193S (Controller), MI-4193S4-18 (Power Amplifier Unit), MI-4190-15 (IEEE Cable), MI-4190-R (Rack Slides), MI-4190-OM3 (Operator Manual)

The base configuration of the MI-4193S4-FP position controller includes operation with linear incremental encoder feedback for the main X and Y axes. The Z and Roll axes can be configured for either incremental encoder or synchro feedback. Customer must specify the feedback mode of the Z and Roll axes or they will be defaulted to encoder. This position controller has been designed exclusively for use with MI Technologies planar scanners. Should there be a requirement to interface this controller to a third party positioner, a through system engineering evaluation would need to be performed to insure compatibility.

The basic MI-4193S4-FP package can accommodate up to 4 axes of control with drive motors to 1 horsepower. The MI-4193S Control Unit has 4 amplifier interface ports with one port required for each axis being operated.

The MI-4193S2-FP and MI-4193S4-FP are used for controlling certain models of MI Technologies' MI-6900 Planar Scanners that are equipped with high performance linear drive systems for the primary X and Y axes. See the MI-6900 product descriptions for more details on the various models. Figure 6 illustrates a 4 Axis Planar Scanner configuration.

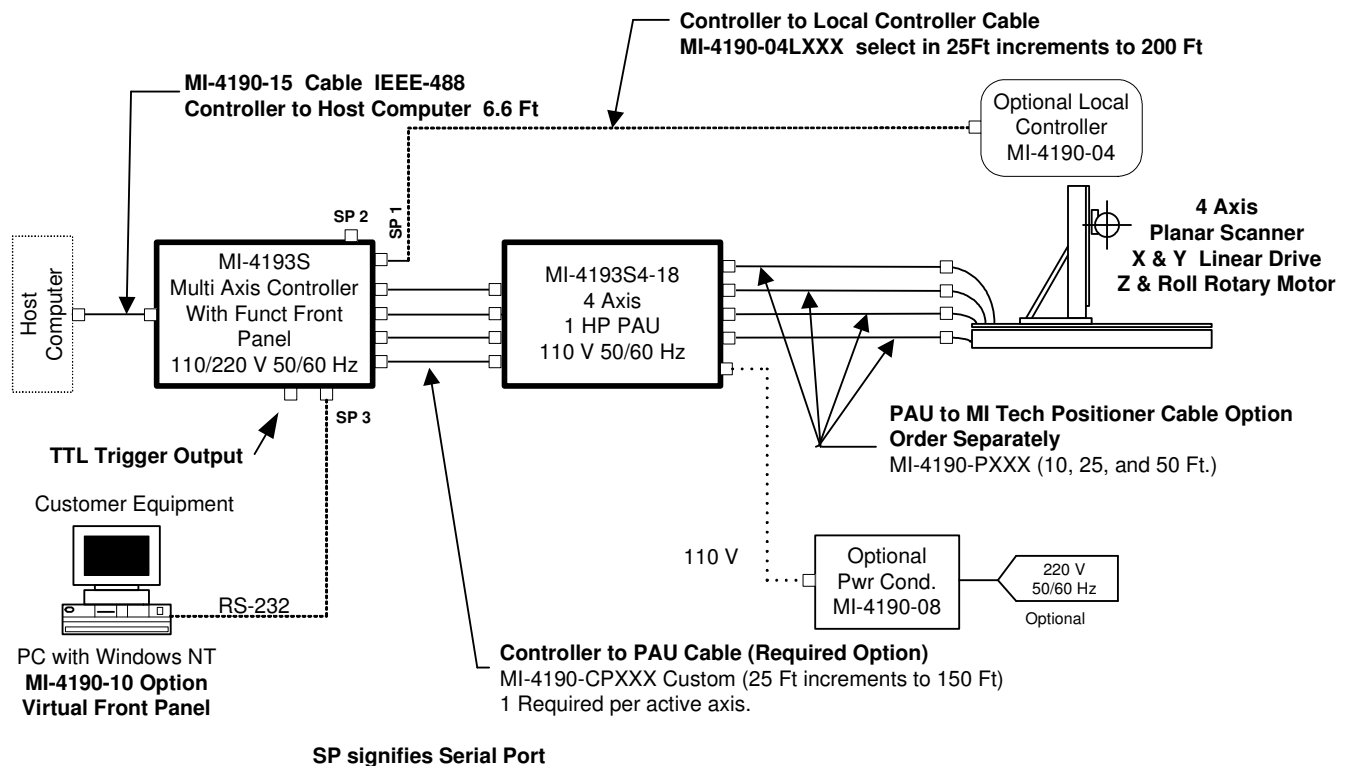

Figure 6 MI-4193S4-FP 4 Axis Planar Scanner Configuration

MI-4190 Position Controllers

Other Options to Consider with the MI-4193S2 and MI-4193S4 Products.

MI-4190-03 Indoor Cabinet Assembly (21 inch high)

This is the standard indoor cabinet for the MI-4190 units and can accommodate up to 3 electronic units.

MI-4190-06 Power Conditioner Module

Consult factory for power conditioner use with MI-4193 Models.

This unit is required in European and other applications where 220 volt supplies are present. The Servo Amplifiers used in the MI-4190 products require 110 volt service for proper operation. This is a required option in the case of 220 volt services.

MI-4190-CPXXX Controller to PAU Cable

This is a required cable that must be selected for connection between the Control Unit and the PAU. The XXX in the model number relates to the available cable lengths to 150 feet in 25 foot length increments, i.e. 025 is 25 ft, 075 is 75 ft ... 150 is 150 ft. The MI-4193 requires that one of these cables be used for each active axis. Up to 4 cables may be required.

MI-4190-PXXX PAU to Positioner Cable

This is a required cable that must be selected for connection between the PAU and the positioner(s). Up to 4 cables may be required. This cable is configured for new positioners which have MI-4190 compatible connector interfaces.. The XXX in the model number relates to the available cable lengths to 150 feet in 25 foot length increments, i.e. 025 is 25 ft, 075 is 75 ft ... 150 is 150 ft.

MI-4190-04 Hand Held Local Control Unit

This unit provides the operator with the ability to operate the controller from a location near the positioner. It provides most of the functions of the Controller front panel. The unit is water resistant, not water proof, and must be stored in a protected location. Connecting cable ordered separately.

MI-4190-04LXXX Controller to Hand Held Local Control Unit Cable

This cable must be ordered with the MI-4190-04, Local Hand Held Unit option. The XXX in the model number relates to the available cable lengths to 200 feet in 25 foot length increments, i.e. 025 is 25 ft, 075 is 75 ft ... 150 is 150 ft.

MI-4190 Position Controllers

MI-4194 Position Controller

The MI-4194 model designation is reserved for custom system engineered Position Control Systems. Configurations can be prepared using a combination of standard and custom product configurations that can provide up to 16 axes of control including mixed combinations of 1 and 5 horsepower positioners. These systems require a thorough evaluation of the customers equipment control requirements in order to identify the appropriate solution. MI Technologies systems engineering personnel are available for consultation with customers that desire a total system solution.

MI-4195BR-FP Position Controller Package

MI-4195BL-FP Position Controller Package

Multi Axis – To 1 Horse Power Version, with Functional Front Panel

Includes MI-4192F (Controller), MI-4195BR-12 or MI-4195BL-12 (Power Amplifier Unit), MI-4190-15 (IEEE Cable), MI-4190-R (Rack Slides), MI-4190-OM2 (Operator Manual)

The base configuration of the MI-4195BX-FP controller includes operation with tachometer and synchro position feedback. The controller can accommodate incremental encoder position feedback under certain conditions but requires consultation with factory to confirm compatibility and application. Incremental encoder operation is not usually recommended with the MI-4195 due to axis switching. Each time an axis is switched, the next axis may have to be indexed to insure accurate position control when using incremental encoders.

The basic MI-4195 packages can accommodate up to 4 axes of control with drive motors to 5 horsepower. The MI-4192F Control unit has 2 PAU interface ports which provide the option to add an additional PAU, increasing the number of axes controllable to 8. The additional PAU may be either the 5 HP capacity MI-4195BX-12 PAU or the MI-4192-11 PAU, if 5 horse power requirements are not needed.

The controller and PAU are delivered with rack slides such that the units can be installed in the customer's rack if desired or select from available cabinets, racks and enclosures from MI Technologies. The MI-4195BX-12 PAU is twice the height of the MI-4192-11 PAU due to the much larger internal amplifier.

This product is designed to support brush (BR designation) or brushless (BL designation) style motors. When one style is selected, all motors of the positioner must be of the same style. Changing from one style to another requires equipment modification at the factory.

Cabling interfaces to the PAU are configured for current MI Technologies production positioners. Cable adapters, conversion boxes, or positioner rewiring may be required for installed equipment.

If outdoor operation is required, the customer will be required to provide an appropriate enclosure to protect the equipment. MI Technologies can quote an outdoor enclosure but requires specific information from the customer regarding general environmental conditions that may be encountered at their location. Facilities restrictions and local codes may need to be addressed.

Figure 7 illustrates a typical product configuration.

MI-4190 Position Controllers

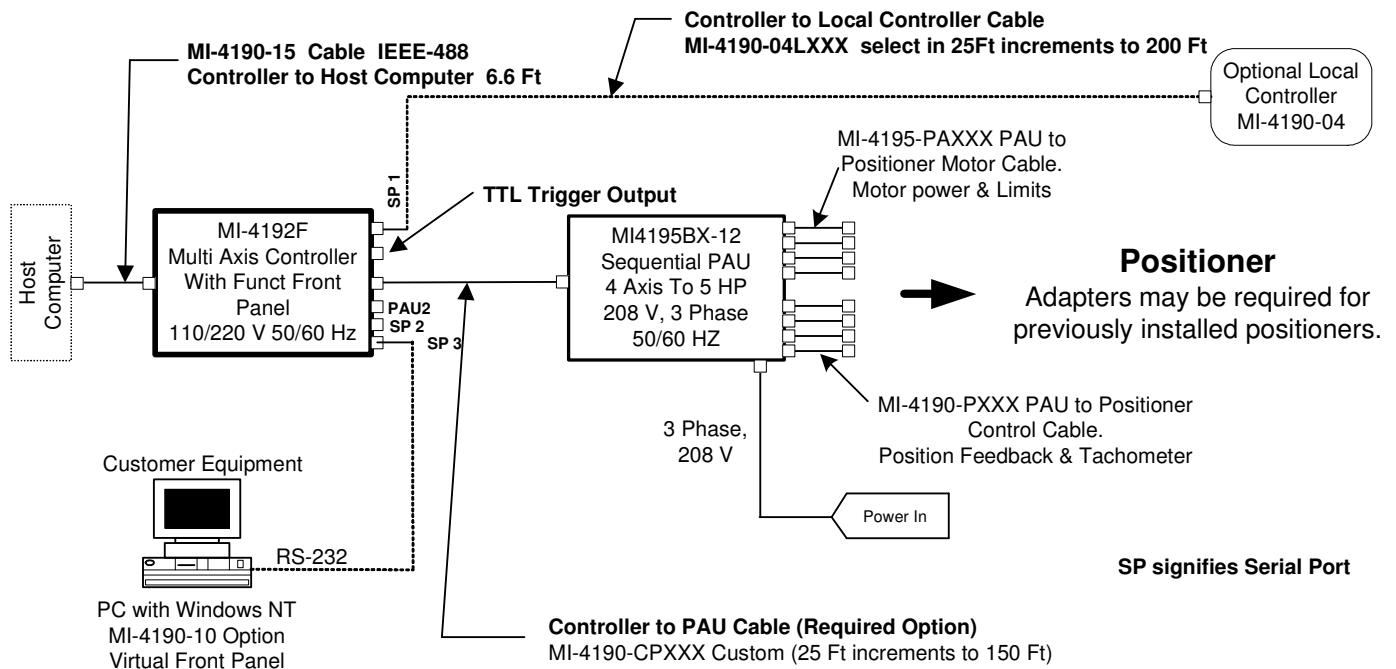

Figure 7

MI-4195BR-FP or MI-4195BL-FP Multi Axis Controller for Positioners up to 5 horsepower

Other Options to Consider with this Product.

MI-4190-03 Indoor Cabinet Assembly
(21 inch high)

This is the standard indoor cabinet for the MI-4190 units and can accommodate the control and the PAU electronic units.

MI-4190-07 Outdoor PAU Enclosure

Enclosure for the protection of the equipment in an outdoor environment. Enclosures should be responsibility of customer. Exact enclosure selection, if purchased from MI Technologies, will require specific environmental information from the customer related to local environmental conditions as well as mounting requirements.

MI-4190-09 Junction Box – MI-4192 to MI-4139

This option provides the customer with the capability to replace a MI-4139 configuration with the MI-4192 and utilize the existing cable set that is currently interfaced to the positioner. See Figure 3 for configuration. The junction box mounts below the PAU and has pigtail cables

Use only when the optional MI-4192-11 option has been ordered.

MI-4190 Position Controllers

MI-4190-12 Junction Box – MI-4195 to MI-4181

that plug into the PAU. The output connections are the same as the MI-4139.

This option provides the customer with the capability to replace a MI-4181 configuration with the MI-4195 and utilize the existing cable set that is currently interfaced to the positioner. The junction box mounts below the PAU and has pigtail cables that plug into the PAU. The output connections are the same as the MI-4181. Synchro feedback is to the Junction Box.

MI-4190-10 Virtual Front Panel

Requires Windows NT operating software on host PC.

Software package that can be installed in a standard PC Computer and be used to operate the MI-4190 Controllers through the Serial Port. This feature can provide ability to locate the controller in a more remote location, yet maintain local control.

MI-4192-11 Power Amp Unit, 4 Axis Sequential

1 Horse Power PAU Option

This option will provide for an additional 4 Axes of control to the controller. If this option is selected, the appropriate cables as shown in figure 2 for the basic PAU will be required. This unit will interface to the PAU2 connector port on the Controller.

MI-4195BR-12 or MI-4195BL-12 Power Amp Unit, 4 Axis Sequential

5 Horse Power PAU Option

This option will provide for an additional 4 Axes of up to 5 horsepower positioner control to the controller. If this option is selected, the appropriate cables as shown in figure 9 for the basic PAU will be required. This unit will interface to the PAU2 connector port on the Controller.

MI-4190-08 Power Conditioner Module

This unit is not currently available.

MI-4190-CPXXX Controller to PAU Cable

This is a required cable that must be selected for connection between the Control Unit and the PAU. The XXX in the model number relates to the available cable lengths to 150 feet in 25 foot length increments, i.e. 025 is 25 ft, 075 is 75 ft ... 150 is 150 ft.

MI-4190-PXXX PAU to Positioner Cable

This is a required cable that must be selected for connection between the PAU and the positioner(s). Up to 4 cables may be required. This cable is configured for new positioners which have MI-4190 compatible connector interfaces. For connections to positioners that

MI-4190 Position Controllers

are already fielded, consult with the factory. The MI-4190-09 or MI-4190-12 Junction Box may be a suitable selection for interfacing to legacy positioners currently interfaced to the MI-4139 or MI-4181 Controller. The XXX in the model number relates to the available cable lengths to 150 feet in 25 foot length increments, i.e. 025 is 25 ft, 075 is 75 ft ... 150 is 150 ft.

MI-4190-PAXXX PAU to Positioner Cable

5 Horsepower Motor and Limit Cable

This is a required cable that must be selected for connection between the PAU and the positioner(s). Up to 4 cables may be required. This cable is configured for new positioners which have MI-4190 compatible connector interfaces. For connections to positioners that are already fielded, consult with the factory. The MI-4190-09 or MI-4190-12 Junction Box may be a suitable selection for interfacing to legacy positioners currently interfaced to the MI-4139 or MI-4181 Controller. The XXX in the model number relates to the 3 available cable lengths i.e. 010 is 10 ft, 025 is 25 ft, 050 is 50 ft.

MI-4190-04 Hand Held Local Control Unit

This unit provides the operator with the ability to operate the controller from a location near the positioner. It provides most of the functions of the Controller front panel. The unit is water resistant, not water proof, and must be stored in a protected location. Connecting cable ordered separately.

MI-4190-04LXXX Controller to Hand Held Local Control Unit Cable

This cable must be ordered with the MI-4190-04, Local Hand Held Unit option. The XXX in the model number relates to the available cable lengths to 200 feet in 25 foot length increments, i.e. 025 is 25 ft, 075 is 75 ft ... 150 is 150 ft.

MI-4190 Position Controllers

Technical Characteristics

The technical characteristics of the MI-4190 Family of position controllers are listed in the Table below.

Characteristic	MI-4191	MI-4192	MI-4193	MI-4195
Number of selectable axes	1 Axis	1-4 sequential (standard) 1-8 sequential (optional)	1-4 simultaneous (standard) 1-16 sequential (optional) Up to 4 Axes Active	1-4 sequential (standard) 1-8 sequential (optional)
Program entry	Front panel menu driven. IEEE-488, Ethernet, or RS-232C remote protocols	Front panel menu driven. IEEE-488, Ethernet, or RS-232C remote protocols	Front panel menu driven. IEEE-488, Ethernet, or RS-232C remote protocols	Front panel menu driven. IEEE-488, Ethernet, or RS-232C remote protocols
Operating Modes	<ul style="list-style-type: none"> Position Velocity Torque Index 	<ul style="list-style-type: none"> Position Velocity Torque Index 	<ul style="list-style-type: none"> Position Velocity Torque Index 	<ul style="list-style-type: none"> Position Velocity Torque Index
Command Position – Rotary	000.000 to 359.999 -180.000 to 179.999	000.000 to 359.999 -180.000 to 179.999	000.000 to 359.999 -180.000 to 179.999	000.000 to 359.999 -180.000 to 179.999
Command Position – Linear	00.0000 to 35.9999 -18.0000 to 17.9999	00.0000 to 35.9999 -18.0000 to 17.9999	00.0000 to 35.9999 -18.0000 to 17.9999	00.0000 to 35.9999 -18.0000 to 17.9999
Speed Control	.1 degree/second Other units can be used	.1 degree/second Other units can be used	.1 degree/second Other units can be used	.1 degree/second Other units can be used
Record Increment	Not recommended for record Increment applications.	0.001 to 9.999 angular units (encoder) 0.01 to 9.99 angular units (dual speed synchro) 0.1 to 9.9 angular units (single speed synchro)	0.001 to 9.999 angular units (encoder) 0.01 to 9.99 angular units (dual speed synchro) 0.1 to 9.9 angular units (single speed synchro)	0.001 to 9.999 angular units (encoder) 0.01 to 9.99 angular units (dual speed synchro) 0.1 to 9.9 angular units (single speed synchro)

MI-4190 Position Controllers

Characteristic	MI-4191	MI-4192	MI-4193	MI-4195
<u>Display Resolution:</u>				
Encoder	0.0001°	0.0001°	0.0001°	0.0001°
Dual Speed Synchro	0.001°	0.001°	0.001°	0.001°
Single Speed Synchro	0.01°	0.01°	0.01°	0.01°
Motor Field Supply	160V VDC, 3.4 amps	160V VDC, 3.4 amps	160V VDC, 3.4 amps	160V VDC, 3.4 amps
Speed Regulation	Synchro or Tach Feedback	Synchro or Tach Feedback	Synchro or Tach Feedback	Synchro or Tach Feedback
Control Unit External Dimensions	18" x 7" x 19" (L x H x W)	18" x 7" x 19" (L x H x W)	18" x 7" x 19" (L x H x W)	18" x 7" x 19" (L x H x W)
Weight Control Unit	41 lbs.	27 lbs.	27 lbs.	27 lbs.
Power Amplifier Unit External Dimensions	Not Applicable	18" x 7" x 19" (L x H x W)	18" x 7" x 19" (L x H x W)	18" x 14" x 19" (L x H x W)
Weight PAU	Not Applicable	49 lbs.	80 lbs.	85 lbs.
Power Requirements Control Unit	110±15 VAC @ 55±8 Hz, 3.5A and 16 A, 1Φ	110±15 VAC @ 55±8 Hz, 3.5A, 1Φ	110±15 VAC @ 55±8 Hz, 3.5A, 1Φ	110±15 VAC @ 55±8 Hz, 3.5A, 1Φ
Power Requirements Power Amplifier Unit	Not Applicable	110±15 VAC @ 55±8 Hz, 19A, 1Φ	110±15 VAC @ 55±8 Hz, 40A, 1Φ	208±15 VAC @ 55±8 Hz, 50A, 3Φ wye
Power Requirements with optional power conditioner	230±25 VAC @ 55±8 Hz, 25A, 1Φ	230±25 VAC @ 55±8 Hz, 25A, 1Φ	230±25 VAC @ 55±8 Hz, 25A, 1Φ	N/A
Operating Temperature	0° to +50° C	0° to +50° C	0° to +50° C	0° to +50° C
Storage Temp	-20° to +75° C	-20° to +75° C	-20° to +75° C	-20° to +75° C

MI-4190 Position Controllers

The diagram shown below illustrates the basic functioning of the MI-4192 and MI-4195 products. This illustrates the sequential attributes of the PAU and the optional second PAU hook-up.

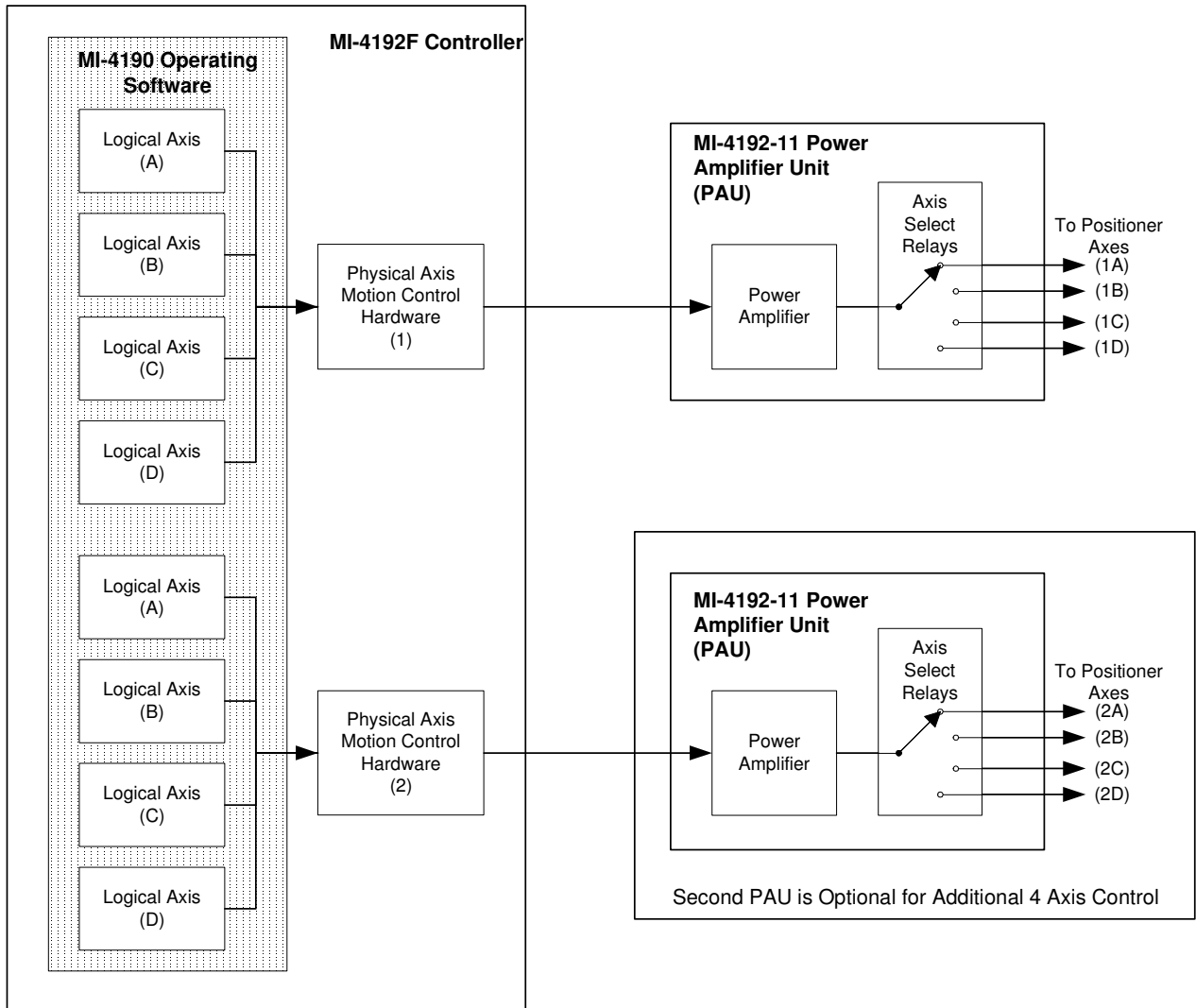

MI-4190 Position Controllers

Operator screen functions are structured as shown below. This diagram identifies the topical aspects of the operational selections available to the operator. These functions are typical of the MI-4190 Family.

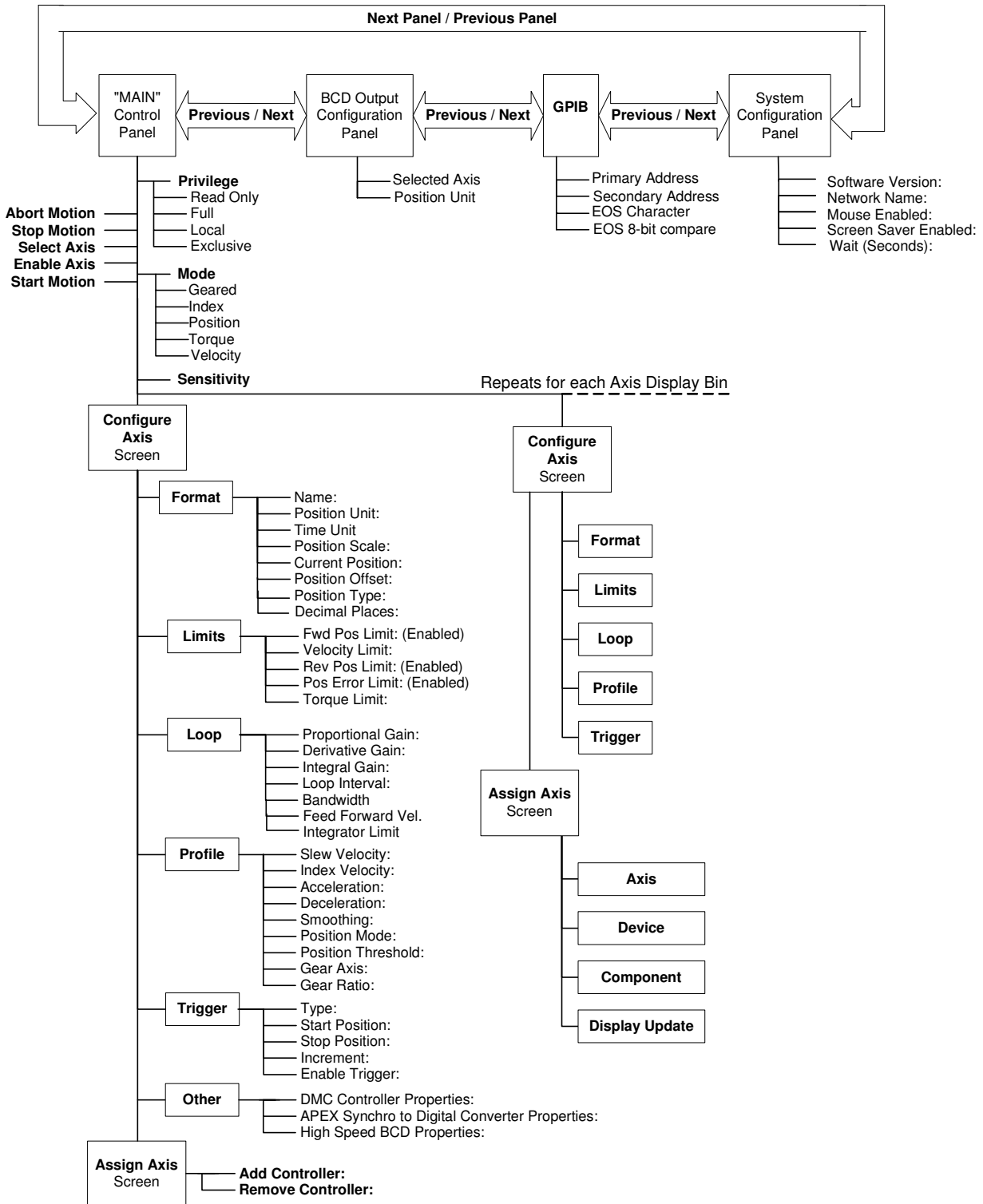

Control unit and basic controls

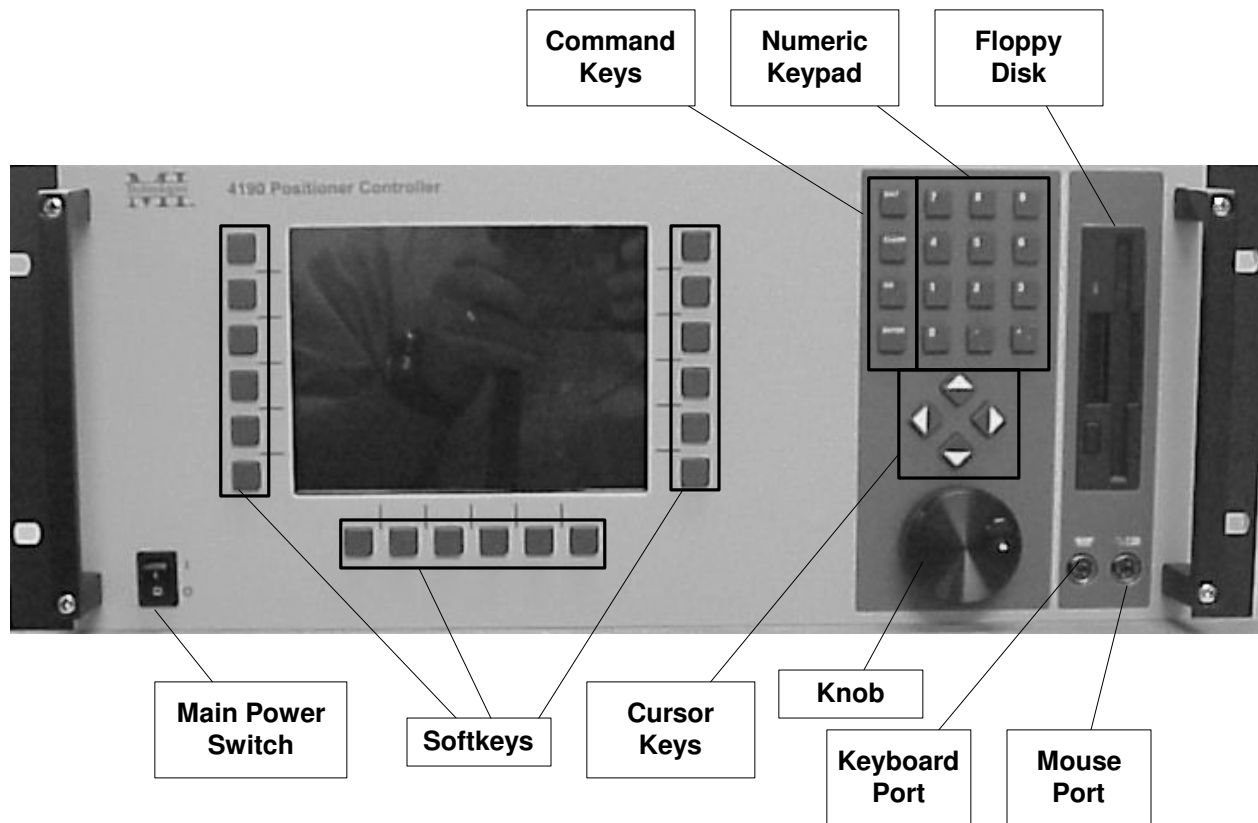

MI-4190 Control Unit Front Panel

Numeric Keypad

A standard 12-key numeric keypad is provided for entering numeric parameters. Four command keys are located to the left of the numeric pad.

EXIT	Presses Cancel on all dialogs.
CLEAR	Deletes the digit immediately to the left of the cursor in the data entry field.
GO	Used to initiate positioner motion following the entry of a command.
ENTER	Completes the entry of a control or setup parameter. Pressing ENTER toggles the status of a checkbox control. Presses OK on all dialogs.

Cursor Keys

A four key directional diamond is located below the numeric keypad. These keys are used to move the Logical Axis Selection Pointer between the Axis Display Bins. They are also used to navigate the configuration menus.

Softkeys

Eighteen softkeys are located adjacent to the LCD display. Their functions depend on the currently displayed key labels.

Knob

A single detented rotary control serves a variety of functions. Its primary function is manual control of the selected axis. Depending on the current motion mode, it can be either a velocity (speed) control or a position jog control. Clockwise (CW) rotation produces forward positioner motion, and counter-clockwise (CCW) rotation produces reverse motion. The velocity/position change per detent sensitivity of the knob is conveniently adjustable to meet various operating requirements.

The knob does not have a marked or otherwise identified STOP position. Pressing in on the knob stops axis motion and, in the velocity mode, sets the commanded velocity to 0. In the position mode, the commanded position is set to the current position.

LCD Display Screen

The left, right, and bottom edges of the LCD Display Screen shown below are always reserved for labels that identify the 18 adjacent softkeys. The contents of the remainder of the screen depend on the currently selected operating screen or configuration menu. For example, on the main operating screen, the central area is divided into eight "Axis Display Bins", and the top of the display shows the current command information.

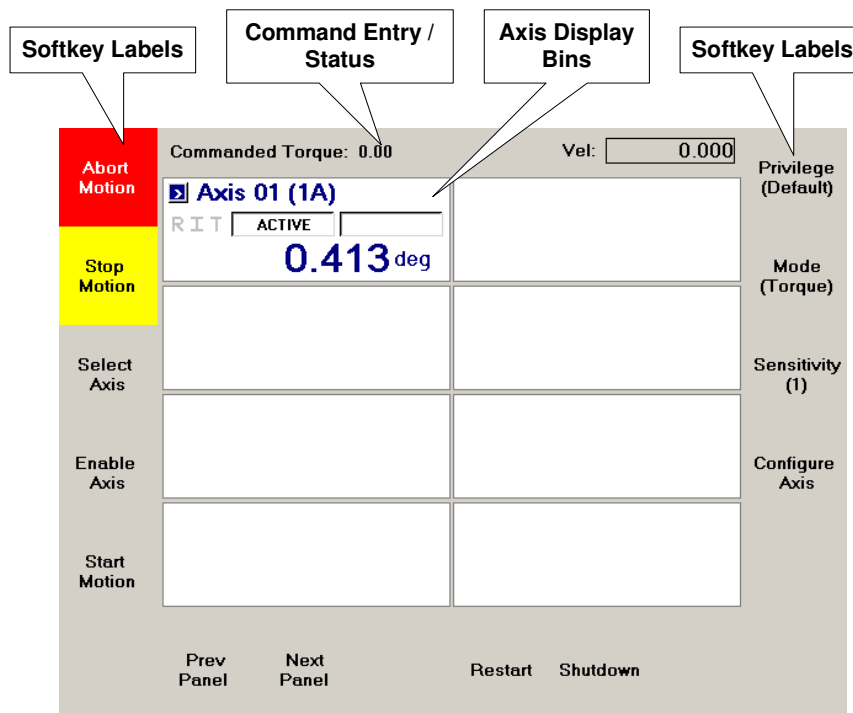

Sample LCD Display Screen

Safety Considerations

The MI-4190 Position Controller can be used in many types of motion control applications ranging from slow-moving, small, lightweight positioners to faster, very large, very heavy load-bearing positioners and/or scanners. Each system application has its own characteristics and requires careful evaluation of appropriate safety measures required both to prevent damage to equipment and keep personnel from harm. Regulatory requirements may also dictate additional safety measures that must be taken that are not defined herein.

This document is not intended to provide complete guidance on what specific features must be used to make a system safe. It is intended to describe several features of the emergency stop interface and limit features that are available in the MI-4190 to use as part of an overall safety and protection system.

As a minimum, all MI Planar Scanners are required to have at least one Emergency Stop button supplied with the system. It is recommended that all positioning systems also have at least one Emergency Stop button supplied with the system, however this decision is to be made by careful review of each system and application.

Description of Features

The Wiring Diagram in Figure 8 depicts the general concept for Emergency Stop and Limit Switch connections. The paragraphs below describe the operation of each feature in detail.

Software Limits

The MI-4190 Controller front panel allows the operator to enter limits on axis travel in the forward and reverse directions using the setup screens as described in the Operator's Manual. These limit conditions are determined by monitoring position feedback. Stopping motion when these limits are detected requires the proper functioning of the servo and mechanical subsystems.

The following conditions must be met for these limits to function correctly:

- Software limits have been selected and entered properly by the operator
- An indexing operation has been successfully completed on axes that require indexing
- Position feedback is correct
- The servo control loop is operating correctly
- No material faults exist in the limit circuit or supporting circuitry
- No material faults exist in the software that impact this function

Emergency Stop operation

The MI-4190 product family has an interface to be used to connect a suitable Emergency stop (E-stop) switch or series of switches. The PAU supplies 24VDC through a relay coil that is routed through normally closed switches back to PAU ground. When the circuit is complete, the PAU relay coil is energized, applying AC Mains to the servo amplifier. When the Emergency stop button is pressed, the circuit is opened, de-energizing the relay and removing AC Mains power from the servo amplifier. The standard circuits are capable of meeting CE requirements for systems that require Category 1 type Emergency Stops (see EN 954-1 "Safety of Machinery" for definitions of categories). Some systems may require Category 2 or 3 Emergency Stops, in which case additional hardware is required to provide the necessary functionality.

The following conditions must be met for these limits to function correctly:

- No short circuit exists that causes the E-stop relay to be activated inadvertently

MI-4190 Position Controllers

- No short circuit exists in the relay or AC wiring that defeats the open contact state of the relay

These conditions can and should be tested regularly by activating the E-stop button and checking for proper operation. This interface is the most reliable means of preventing motion during service operations.

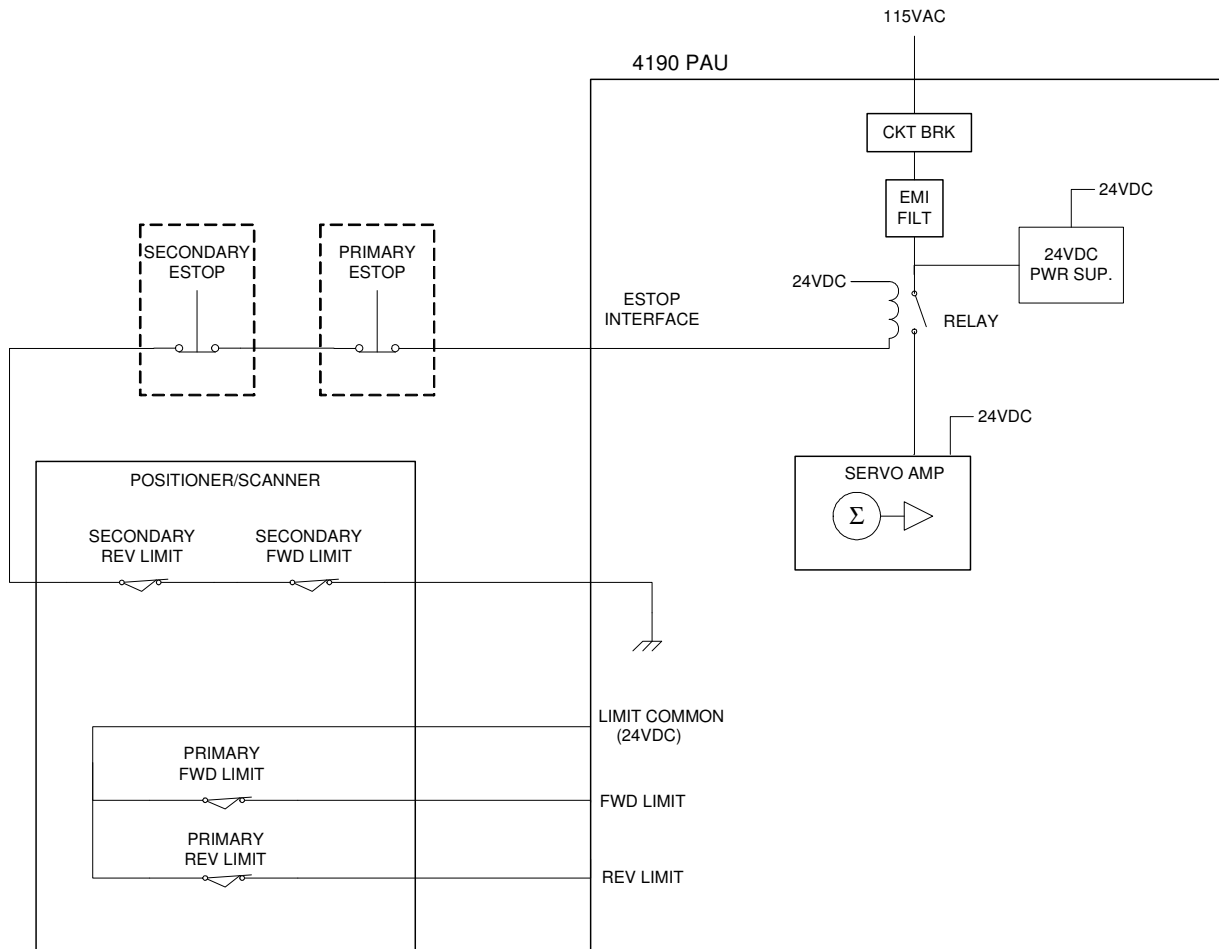

Figure 8. Wiring Diagram

For systems with an E-stop button, a keyed lockout function is also built-in to the switch. This is necessary on some systems to meet regulatory safety requirements.

For systems that do not have an E-stop button, a jumper plug must be installed on the rear panel connector for the PAU to operate. In these systems, the jumper plug may be removed and retained as a precaution to prevent motion during service operations. Turning off power to the PAU is also good, but it can easily be turned back on inadvertently. By retaining the plug, it is much more difficult for someone else to reapply power. The safest practice for service personnel is to cut off PAU power and remove and retain the jumper plug during service.

Turning off power at the Controller is less reliable and is unsuitable for use as an Emergency Stop control mechanism. If the Emergency Stop function is required at the Controller, an Emergency

stop button must be provided at that location.

Primary Limit Switches

Primary Limits Switches are intended to be used by the Controller software to detect physical limits and gracefully recover without operator intervention. These limits may be routinely activated during indexing operations after powering the unit on.

Primary limit switches drive circuits that feed back to the Controller and are indicated on its front panel. The limit condition is true when the circuit is open. These switches are used by the software in the Controller to disable motion in the direction of the limit. Some “Disable” or “Standby” switches activate both limits simultaneously, which the Controller interprets through software as a standby condition, disabling motion in either direction. Activating either or both of these limits does not remove power from the servo amplifier in the PAU. Therefore, certain fault conditions could cause motion.

The following conditions must be met for these limits to function correctly:

- The servo control loop is operating correctly
- No material faults exist in the limit circuit or supporting circuitry
- No material faults exist in the software that impact this function

Secondary Limit Switches

Secondary Limit Switches are intended to be used in situations where it is desired to cut power to the servo amp when a physical location is reached, such as if a runaway condition were to occur. These switches should be wired into the Emergency Stop circuit. The switches should be designed to open if the limit is reached and remain open if travel extends past the point of the limit.

Operator intervention will be required to use the system if these switches maintain an open circuit condition. Carefully examine the system to determine and resolve the root cause prior to operating the system again. The specific mechanisms for redeploying the system vary with the particular implementation.

The following conditions must be met for these limits to function correctly:

- Same as for the Emergency Stop circuit

Mechanical Stop

On some positioners or scanners, a hard mechanical stop or shock absorber may be installed to prevent damage under a runaway condition. These stops must be designed to withstand the maximum inertia that can be generated by the PAU, motor, load, and positioning system plus adequate safety factor. It may be desirable to also use secondary limits to remove power to the servo amp prior to reaching the mechanical stop.

If mechanical stops are struck, the system should be carefully examined to determine and resolve the root cause prior to operating the system again. The stops should also be examined for damage and any necessary repairs performed.

The following conditions must be met for these limits to function correctly:

- The maximum inertia for which the stop was designed must not be exceeded

Local Control Unit

The Local Control Unit has a large button on top that is labeled Local/Remote and also has liveman switches on the side that must be pressed to move an axis. At times, either of these have been incorrectly interpreted to be equivalent to an Emergency stop mechanism, however, neither of these switches is connected to the Emergency stop circuit previously described. The liveman switches do affect the Primary Limit lines and create a Standby condition if neither button is depressed. The liveman circuit has the same limitations as Primary Limit Switches. Neither the large Local/Remote button nor the liveman switches should be considered equivalent to the Emergency Stop circuit.

Order of limits

The limits should ordinarily be set up in the system so that when traveling in a given direction, they are encountered in the following order:

1. Software Limits
2. Primary Limit Switches
3. Secondary Limit Switches
4. Mechanical Stop

It is desirable to have sufficient spacing between limits such that at each limit appropriate actions can be taken to prevent travel into a subsequent limit. Otherwise, the function of each limit may be compromised.

Hardware description

The Emergency Stop interface connector is located on the MI-4190 PAU, regardless of the specific Model. The Emergency Stop Master station is to be connected to this interface. If no Emergency Stop button is required, this connector must have a jumper plug installed to operate the system.

The Emergency Stop Master station has one E-stop button that can control up to 4 MI-4190 PAUs with a single pushbutton switch. It includes a key mechanism for lockout capability. It supports daisy chain connection of additional Emergency Stop Slave stations to support systems that require more than one Emergency Stop control point.

This document contains specifications and information that are subject to change without notice. This guide is intended to assist buyers in the selection of product configurations that can provide the best position management solution required for their application needs.

Revision Notes.

- 3/28/00 Added note to figure 4 on MI-4193 requiring that motor returns be separated.
- 4/7/00 Added note to MI-4193 functional diagram indicating that rewiring of legacy positioners may be required to separate motor return lines. Added introduction. Moved product description write-up from back of sections to front.
- 10/13/00 Extensively revised to reflect current model numbers and configurations.
- 5/15/02 Revised to update current model information.
- 10/23/02 Added some additional data related to Front Panel operation
- 4/20/05 General update, plus added section on Safety Considerations, including requirement that all planar scanners have an Emergency Stop
- 7/07/05 Corrected with a few comments from reviewers
- 8/23/05 Ethernet is now included with IEEE-488 in the standard unit and is no longer optional.



MI-4190 Position Controllers

Notes